

**CHAPTER 22, APPENDIX A**  
**SPECIFICATONS AND DESIGN STANDARDS**

**PART 1 Title and Purpose**

§22A-101. Title .....	2
§22A-102. Adoption .....	2
§22A-103. Application .....	2

**PART 2 Definitions**

§22A-201. General .....	3
-------------------------	---

**PART 3 Design Standards**

§22A-301. General Standards .....	4
-----------------------------------	---

**PART 4 Design Specifications and Details**

§22A-401. Landscape Specifications .....	7
§22A-402. Roadway Specifications .....	11
§22A-403. Concrete Specifications .....	18
§22A-404. Traffic Signal Specifications .....	22

**PART 1**  
**TITLE AND PURPOSE**

**§22A-101. Title**

- A. This appendix may be sited as the "Bristol Borough Specifications and Design Standards."

**§22A-102. Adoption**

- A. The standards and regulations herein are incorporated by reference into the Bristol Borough Subdivision and Land Development Regulations.
- B. These standards and regulations may be amended and updated, from time to time, by Borough Council by resolution.

**§22A-103. Application**

- A. The standards and requirements outlined herein shall be considered minimum safety standards and requirements for the promotion of the public health, morals, and general welfare.
- B. Where literal compliance with the standards herein specified is clearly impractical, the Borough Council may modify or adjust the standards to permit reasonable utilization of property while securing substantial conformance with the objectives of these regulations.
- C. The application of these standards in the design of improvements shall be coordinated with the Public Works Superintendent and the Borough Engineer during the plan review stage.
- D. The use of these standards, specifications and details are not intended to replace or supersede technical design and analysis, sound engineering judgment, or other approved methods. The Borough, Borough Staff, Borough Council, the Borough Engineer, or their assigns are not responsible for the adequacy or lack thereof regarding these standards, specifications and details.

**PART 2**  
**DEFINITIONS**

**§22A-201. General**

- A. Unless defined herein, all definitions necessary for interpreting the Borough of Bristol Specifications and Design Standards, are set forth in Part 2 of the Bristol Borough Subdivision and Land Development Regulations.

**PART 3**  
**DESIGN STANDARDS**

**§22A-301. General Standards**

- A. The following improvements (new or replacement) require construction observation by the Borough Public Works Superintendent and the Borough Engineer or their representative(s):
1. Street, parking lot, and driveway paving, stone bedding, sub-grading and preparation
  2. Curbs, sidewalks, curb ramps and driveway aprons
  3. Storm sewer structures and pipe installations
  4. Stormwater management facility installation, berm compaction
  5. Light pole foundations
  6. Retaining walls
  7. Traffic signal
  8. Related construction associated with above
- B. The Public Works Superintendent or Traffic Foreman and the Borough Engineer must be notified 48 hours in advance of such installations or repairs. Should the contractor or developer fail to notify the above listed persons, the installation of any of the above will not be approved. Disapproval means the installation of any of the above be completely removed and replaced with no exceptions.
- C. Shop drawings shall be submitted to the Borough Engineer for review and be approved prior to start of construction.
- D. All improvements shall be constructed in accordance with the Specifications and Design Standards provided herein and/or other regulations from Bristol Borough, Pennsylvania Department of Transportation (PennDOT), Pennsylvania Department of Environmental Protection (PADEP), Bucks County Conservations District (BCCD), and those of the agency or utility owner having jurisdiction over the improvements. When there is a conflict of specifications or design standards, the most restrictive parameter shall be implemented.
- E. Prior to the start of all construction or maintenance activities, the required permits and applicable notifications shall be obtained from all applicable local, state, and federal regulatory agencies.
- F. Maintenance and protection of traffic shall be addressed for all construction, maintenance, and utility work on or adjacent to all roads within the Borough. Guidelines as established by the PennDOT Publication 408, Section 900, Traffic Accommodation and Control, latest edition, and PennDOT Publication 213, Temporary Control Guidelines, latest edition.
- G. Scaled dimensions shall not be used in any case. A clarification must be obtained from the Engineer in cases of discrepancies or questions.
- H. When changes from the approved drawings and specifications become necessary during construction, a written request shall be submitted to the Borough Engineer for review and approval before execution of such changes.

- I. Improvements shall be compliant with the Americans with Disabilities Act (ADA) to the extent required by the ADA or as required by Borough Council.
- J. The specifications outlined herein set forth basic principals and guidelines and are considered minimum requirements for land development and construction to promote the health, safety, and general welfare of Borough residents. Existing site specific conditions and/or proposed development considerations may dictate and increase in these minimum standards.

**PART 4**  
**DESIGN SPECIFICATIONS AND DETAILS**

**§22A-401. Landscape Specifications**

- A. Table 401.A - Approved Plant Material

**§22A-402. Roadway Specifications**

- A. 100R - Typical Roadway Section for Borough Roads
- B. 101R - Roadway Dedication Checklist for Engineer's Approval
- C. 102R - Roadway Opening Repair Standards
- D. 103R - Pavement Detail for Borough Roads
- E. 104R – Pavement Detail for Truck Traffic on Driveways and Parking Lots
- F. 105R – Pavement Detail for Car Traffic Only on Driveways and Parking Lots
- G. 106R – Pavement Detail for Single-Family Residential Driveways
- H. 107R - Pavement Base Drain Detail
- I. 108R - Temporary Restoration of Borough Roads
- J. 109R - Trench Backfill Restoration Detail for Paved Areas
- K. 110R - Trench Backfill Restoration Detail for Non-Paved Areas
- L. 111R - Pervious Paving
- M. 112R - Intersection and Roadway Alignment Standards
- N. 113R - Parking Stall and Aisle Dimensions

**§22A-403. Concrete Specifications**

- A. 200C - Standard Concrete Curb for Non-PennDOT Applications
- B. 201C - Depressed Concrete Curb for Driveways
- C. 202C - Tapered Concrete Curb for Non-PennDOT Applications
- D. 203C - Concrete Sidewalk Installation
- E. 204C - Concrete Apron for Driveway Crossings

**§22A-404. Traffic Signal Specifications**

- A. 34 41 16 - Traffic Signal Specifications

**TABLE 401.A  
APPROVED PLANT MATERIAL**

**Deciduous Shade Trees**

<b>Species Name 'cultivar name'</b>	<b>Common Name</b>
Acer rubrum and hybrids	standard and hybrid Red Maple (many cultivars; 'Autumn Flame' and 'Red Sunset' may have better branching structure than 'October Glory' or 'Armstrong')
Acer saccharum and hybrids	standard and hybrid Sugar Maple
Carya ovata	Shagbark Hickory
Carya laciniosa	Shellbark Hickory
Celtis laevigata 'All Seasons'	Sugar hackberry
Celtis occidentalis 'Prairie Pride,'Magnifica'	Hackberry
Cladrastis kentuckea	American Yellowwood
Corylus columna	Turkish filbert
Eucommia ulmoides	Hardy rubber tree
Fraxinus americana and hybrids	standard and hybrid White Ash
Fraxinus pennsylvanica and hybrids	standard and hybrid Green Ash
Ginkgo biloba	Ginkgo (male selections only)
Gleditsia triacanthos 'Inermis'	Thornless honeylocust
Gymnocladus dioicus	Kentucky coffee tree (male cultivars like 'Macho')
Liquidambar styraciflua	Sweet Gum
Liquidambar styraciflua 'Rotundiloba'	Fruitless Sweet Gum
Metasequoia glyptostroboides	Dawn redwood
Nyssa sylvatica	Black gum
Platanus x acerifolia	London plane tree
Prunus serotina	Black Cherry
Quercus alba	White oak
Quercus bicolor	Swamp white oak
Quercus imbricaria	Shingle oak
Quercus phellos	Willow oak
Quercus robur	English oak
Quercus shumardii	Shumard oak
Sassafras albidum	Common Sassafras
Sophora japonica 'Halka,'Regenf	Japanese scholar tree
Taxodium distichum	Bald cypress
Tilia americana 'WandelP	Legend American linden
Tilia americana 'Redmond'	Redmond linden
Tilia cordata	Little leaf linden cultivars
Tilia euchlora	Crimean linden (ungrafted specimens)
Tilia tomentosa	Silver linden
Ulmus parviflora	Hybrid Chinese Elm
Ulmus x hybrids	Homestead, Princeton, Liberty Elm
Zelkova serrata 'Village Green' or 'Halka'	Japanese zelkova

**TABLE 401.A (cont.)  
APPROVED PLANT MATERIAL**

**Desiduous Ornamental Trees)**

<b>Species Name 'cultivar name'</b>	<b>Common Name</b>
Acer campestre	Hedge maple
Acer campestre 'Queen Elizabeth'	Queen Elizabeth hedge maple
Acer ginnala	Amur Maple
Acer griseum	Paperbark Maple
Acer palmatum var.	Japanese Maple variety
Acer tataricum	Tatarian maple
Aesculus x carnea 'Briotii'	Ruby red chestnut (specify street tree form)
Amelanchier canadensis and hybrids	standard and hybrid Shadblow Serviceberry
Amelanchier x grandiflora and hybrids	standard and hybrid Apple Serviceberry
Carpinus betulus 'Fastigiata'	Upright european hornbeam
Carpinus caroliniana	American hornbeam
Cercidiphyllum japonica	Katsura Tree
Cercis canadensis and hybrids	standard and hybrid Eastern Redbud
Chionanthus retusus	Chinese Fringetree
Chionanthus virginicus	White Fringetree
Cornus florida and hybrids	standard and hybrid Flowering Dogwood
Cornus kousa and hybrids	standard and hybrid Kousa Dogwood
Cornus kousa x florida	Hybrid Dogwood
Cornus mas	Cornelian Cherry Dogwood
Crataegus crus-galli 'Inermis'	Thornless cockspur hawthorn
Crataegus veridis 'Winter King'	Winter King Green Hawthorn
Halesia Carolina and hybrids	standard and hybrid Carolina Silverbell
Koelreuteria paniculata	Goldenraintree
Koelreuteria paniculata	Golden rain tree
Magnolia hybrids	hybrid Magnolia
Magnolia loebneri	Dr. Merrill Magnolia
Magnolia soulangiana	Saucer Magnolia
Magnolia stellata	Royal Star Magnolia
Magnolia virginiana	Sweet Bay Magnolia
Malus species	Flowering Crab Apple (disease resistant var. only)
Oxydendrum arboretum	Sourwood
Phellodendron amurense 'Macho'	Amur cork tree (male trees only)
Prunus cerasifera and hybrids	standard and hybrid Myrobalan Plum
Prunus maritime	Beach Plum
Prunus sargentii and hybrids	standard and hybrid Sargent Cherry
Prunus serrulata and hybrids	standard and hybrid Japanese Flowering Cherry
Prunus subhirtella and hybrids	standard and hybrid Higan Cherry
Prunus x incam 'Okame'	Okame Cherry
Prunus yedoensis	Yoshino cherry
Quercus acutissima	Sawtooth oak
Sorbus alnifolia	Korean mountain ash
Sorbus aucuparia	European mountain ash
Sorbus aucuparia 'Fastigiata'	Upright mountain ash
Stewartia pseudocamellia	Japanese Stewartia
Styrax japonica	Japanese Snowbell
Styrax obassia	American Snowbell
Syringa reticulata 'Summer Snow', 'Regent', 'Ivory Silk'	Japanese tree lilac



**TABLE 401.A (cont.)  
APPROVED PLANT MATERIAL**

**Evergreen Trees**

<b>Species Name 'cultivar name'</b>	<b>Common Name</b>
Abies concolor	White Fir
Ilex opaca and hybrids	standard and hybrid American Holly
Ilex x Nellie Stevens	Nellie Stevens Holly
Juniperus virginiana and hybrids	standard and hybrid Eastern Redcedar
Picea species and hybrids	standard and hybrid Spruce
Pinus flexilis 'Vanderwolf's Pyramid'	Vanderwolf's Pyramid Limber Pine
Pinus strobes 'Fastigiata'	Fastigate White Pine
Pinus strobus	Eastern White Pine

**Large Shrubs**

<b>Species Name 'cultivar name'</b>	<b>Common Name</b>
Aesculus parviflora	Bottlebrush Buckeye
Aronia arbutifolia and hybrids	standard and hybrid Red Chokeberry
Aronia melanocarpa	Black Chokeberry
Cornus sericea	Redosier Dogwood
Corylus americana	American Filbert
Cotinus coggygria	Common Smoketree
Cotinus obovatus	American Smoketree
Hamamelis vernalis	Vernal Witchhazel
Hamamelis virginiana	Common Witchhazel
Hamamelis x intermedia	Hybrid Witchhazel
Syringa species and hybrids	standard and hybrid Lilac
Thuja occidentalis 'Nigra'	Dark American Arborvitae
Viburnum dentatum and hybrids	standard and hybrid Arrowwood Viburnum
Viburnum dilatatum and hybrids	standard and hybrid Linden Viburnum
Viburnum nudum and hybrids	standard and hybrid Witherod Viburnum
Viburnum plicatum tomentosum and hybrids	standard and hybrid Doublefile Viburnum
Viburnum prunifolium	Blackhaw Viburnum
Viburnum trilobum and hybrids	standard and hybrid Cranberrybush Viburnum

**TABLE 401.A (cont.)  
APPROVED PLANT MATERIAL**

**Medium Shrubs**

<b>Species Name 'cultivar name'</b>	<b>Common Name</b>
Clethra alnifolia and hybrids	standard and hybrid Summersweet Clethra
Forsythia x intermedia	Border Forsythia
Fothergilla major and hybrids	standard and hybrid Large Fothergilla
Hydrangea species and hybrids	standard and hybrid Hydrangea
Ilex crenata and hybrids	standard and hybrid Japanese Holly
Ilex glabra and hybrids	standard and hybrid Inkberry Holly
Ilex verticillata and hybrids	standard and hybrid Winterberry Holly
Itea virginica and hybrids	standard and hybrid Sweetspire
Kalmia latifolia and hybrids	standard and hybrid Mountain laurel
Lindera benzoin	Spicebush
Myrica pennsylvanica	Northern Bayberry
Prunus x laurocerasus and hybrids	standard and hybrid Cherry Laurel
Rhododendron species and hybrids	standard and hybrid Rhododendron
Taxus baccata 'Repandens'	Spreading English Yew
Taxus x media 'Densiformis'	Dense Yew
Taxus x media 'Hicksii'	Hicks Yew

**Small Shrubs**

<b>Species Name 'cultivar name'</b>	<b>Common Name</b>
Abelia grandiflora and hybrids	standard and hybrid Glossy Abelia
Forsythia viridissima 'Bronxensis'	Bronx Greenstem Forsythia
Fothergilla gardenia	Dwarf Fothergilla
Hypericum species and hybrids	standard and hybrid St. Johnswort
Itea virginica 'Little Henry'	Little Henry Sweetspire
Juniperus species and hybrids	standard and hybrid Juniper
Leucothoe axillaries	Coast Leucothoe
Potentilla fruticosa and hybrids	standard and hybrid Cinquefoil
Rhododendron species and hybrids	standard and hybrid Rhododendron
Rhus aromatica and hybrids	standard and hybrid Fragrant Sumac
Rosa species and hybrids	standard and hybrid Rose
Spirea species and hybrids	standard and hybrid Spirea

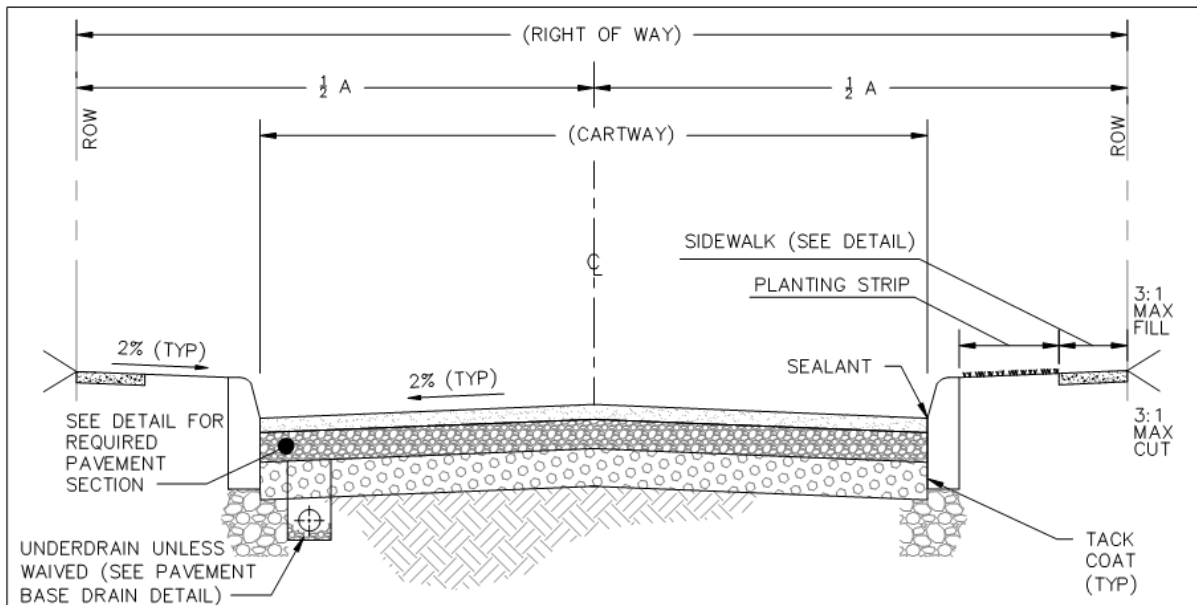

- \* DIMENSIONS PER SALDO SECTION 22-507
- \*\* VARIES DEPENDING UPON PADOT CARTWAY REQUIREMENTS.

**NOTES:**

1. ALL CONSTRUCTION TO CONFORM TO PADOT PUBLICATION 408, LATEST EDITION.
2. ALL NEW STREETS SHALL BE PROPERLY POSTED W/SPEED LIMIT SIGNS IN ACCORDANCE WITH DESIGN SPEED.
3. REQUIRED MINIMUM WIDTH OF PLANTING STRIP AND SIDEWALK PER DETAIL 203C AND PADOT RC-67, LATEST ADDITION.
4. AN EASEMENT SHALL BE PROVIDED FOR ALL PROPOSED SIDEWALKS NOT LOCATED WITHIN THE PUBLIC RIGHT-OF-WAY. THE SIDEWALK SHALL BE MAINTAINED IN ACCORDANCE WITH "MAINTENANCE OF EXISTING SIDEWALKS AND CURBS."
5. A TACK COAT SHALL BE APPLIED TO ALL VERTICAL SURFACES BELOW PAVING LINE. IF BASE COURSE IS IN PLACE FOR MORE THAN 30 DAYS THE SURFACE MUST BE CLEANED AND TACK COATED PRIOR TO INSTALLATION OF THE WEARING COURSE. TACK COAT SHALL BE PER PADOT PUBLICATION 408, SECTION 460.
6. ALL ASPHALT JOINTS INCLUDING ALONG THE CURB LINE SHALL BE SEALED WITH ASPHALT PG64-22 SEALANT OR APPROVED EQUAL. JOINT AND CRACK SEALING SHALL BE PER PADOT PUBLICATION 408, SECTION 469.

**TYPICAL ROADWAY SECTION FOR BOROUGH ROADS**

**GILMORE & ASSOCIATES, INC.**  
**ENGINEERING & CONSULTING SERVICES**  
65 EAST BUTLER AVENUE, SUITE 100  
 NEW BRITAIN, PA 18901-5108 • (215) 345-4330  
 www.gilmore-assoc.com

*BOROUGH OF BRISTOL*  
 SPECIFICATIONS AND DESIGN STANDARDS  
 250 POND STREET BRISTOL, PA 19007 (215) 788-3828

DATE:	OCTOBER 2023
	NOT TO SCALE
DETAIL:	100R

DURING THE COURSES OF CONSTRUCTION OF ROADS THE ENGINEER MUST BE NOTIFIED 48 HOURS PRIOR TO THE FOLLOWING OPERATIONS:

1. PREPARATION OF THE SUBGRADE
2. LAYING AND ROLLING OF THE SUBBASE
3. LAYING AND ROLLING OF THE BINDER COURSE
4. LAYING AND ROLLING OF THE WEARING COURSE
5. POURING OF CONCRETE CURBS
6. POURING OF CONCRETE SIDEWALKS
7. POURING OF CONCRETE DRIVEWAY APRONS
8. TRENCH BACKFILL FOR ALL UTILITIES
9. INFRARED PAVEMENT RESTORATION

THE FOLLOWING ITEMS WILL BE CAUSE FOR REJECTION OF THE PAVING, CURBS, DRIVEWAY APRONS, AND SIDEWALKS BY THE ENGINEER.

I. PAVING

1. ALLIGATOR SURFACE, CRACKING OR OTHER DETERIORATION INDICATING SUBGRADE FAILURE.
2. DIPS OR DEPRESSIONS INDICATING EXCESSIVE SETTLEMENT UNDER THE PAVING, INCLUDING TRENCHES SUCH AS FOR WATER LINE, SEWER LINE, GAS LINE.
3. POT HOLES OR OTHER SURFACE BREAKS.
4. EXCESSIVE SURFACE SCARRING CAUSED BY CONTRACTORS EQUIPMENT (EG. BULLDOZER TRACKS).
5. IRREGULARITIES CAUSING PONDING.
6. PAVING DOES NOT MEET DRAINAGE STANDARDS.
7. WORK NOT COMPLETED IN COMPLIANCE WITH PADOT PUB 408, LATEST EDITION AND PADOT DETAILS RC-67, LATEST EDITION.
8. WORK NOT COMPLETED IN COMPLIANCE WITH OF ADAAG AND/OR PROWAG, LATEST EDITIONS.

II. CURBS

1. METHODS AND MATERIALS NOT MEETING MINIMUM SPECIFICATIONS PROVIDED IN THE DETAIL.
2. CHIPS MORE THAN ¼ INCH DEEP.
3. CRACKS OF ANY WIDTH.
4. MISALIGNMENT MORE THAN ¼ INCH IN ANY DIRECTION AT CRACKS OR JOINTS.
5. WORK NOT COMPLETED IN COMPLIANCE WITH PADOT PUB 408, LATEST EDITION AND PADOT DETAILS RC-64 AND RC-67, LATEST EDITION.
6. WORK NOT COMPLETED IN COMPLIANCE WITH ADAAG AND/OR PROWAG, LATEST EDITIONS.

III. CURBS (DEPRESSED)

1. METHODS AND MATERIALS NOT MEETING MINIMUM SPECIFICATIONS PROVIDED IN THE DETAIL.
2. ANY DEPRESSED CURB THAT IS FORMED BY CHIPPING OUT OF STRAIGHT CURB. DEPRESSED CURBS MUST BE MADE BY COMPLETE REMOVAL OF THE STRAIGHT CURB TO THE NEAREST JOINT BEYOND THE DEPRESSED AREA AND NEW DEPRESSED CURB SECTIONS POURED.
3. ANY DEPRESSED CURB THAT HAS A LIP MORE THAN 1 ½ INCHES ABOVE THE EDGE OF PAVING AT DRIVEWAY APRONS OR MORE THAN ¼ INCH AT CURB RAMPS.
4. CHIPS MORE THAN ¼ INCH DEEP.
5. CRACKS OF ANY WIDTH.
6. MISALIGNMENT MORE THAN ¼ INCH IN ANY DIRECTION AT CRACKS OR JOINTS.
7. WORK NOT COMPLETED IN COMPLIANCE WITH PADOT PUB 408, LATEST EDITION AND PADOT DETAILS RC-64 AND RC-67, LATEST EDITION.
8. WORK NOT COMPLETED IN COMPLIANCE WITH ADAAG AND/OR PROWAG, LATEST EDITIONS..

IV. DRIVEWAY APRON

1. METHODS AND MATERIALS NOT MEETING MINIMUM SPECIFICATIONS PROVIDED IN THE DETAIL.
2. CRACKS OF ANY WIDTH.
3. CHIPS MORE THAN ¼ INCH DEEP.
4. MISALIGNMENT MORE THAN 1/4 INCH IN ANY DIRECTION AT JOINTS.
5. MONOLITHIC POURS BETWEEN CURB & APRON, APRON SIDEWALK & ADJACENT SIDEWALK, AS SHOWN IN DETAIL 204C "CONCRETE DRIVEWAY APRON FOR DRIVEWAYS".
6. CONFIGURATIONS AND CHANGES IN GRADE NOT IN COMPLIANCE WITH PADOT PUBLICATION 13M (DM-2), CHAPTER 7.
7. WORK NOT COMPLETED IN COMPLIANCE WITH PADOT PUB 408, LATEST EDITION AND PADOT DETAILS RC-67, LATEST EDITION.
8. WORK NOT COMPLETED IN COMPLIANCE WITH ADAAG AND/OR PROWAG, LATEST EDITIONS..

V. SIDEWALK

1. METHODS AND MATERIALS NOT MEETING MINIMUM SPECIFICATIONS PROVIDED IN THE DETAIL.
2. ANY DRIVEWAY BLOCK FORMING PART OF THE SIDEWALK, WHICH DOES NOT CORRESPOND TO DRIVE APRON.
3. ANY CRACK, OTHER THAN AT AN EXPANSION OR CONTRACTION JOINT OF ANY WIDTH.
4. MISALIGNMENT IN A VERTICAL DIRECTION MORE THAN 1/4 INCH AT ANY CRACK OR JOINT.
5. INSTALLATION OF SIDEWALK AND CURB RAMPS FOR HANDICAP ACCESS SHALL MEET ADA REQUIREMENTS AND SHALL BE IN ACCORDANCE WITH PADOT DETAILS RC-67, LATEST EDITION. PADOT DETAILS ARE INCLUDED HEREWITH BY REFERENCE.
6. WORK NOT COMPLETED IN COMPLIANCE WITH PADOT PUB 408, LATEST EDITION.
7. WORK NOT COMPLETED IN COMPLIANCE WITH ADAAG AND/OR PROWAG, LATEST EDITIONS.

**ROADWAY OPENING & DEDICATION CHECKLIST FOR ENGINEER'S APPROVAL**



**GILMORE & ASSOCIATES, INC.**  
**ENGINEERING & CONSULTING SERVICES**  
 65 EAST BUTLER AVENUE, SUITE 100  
 NEW BRITAIN, PA 18901-5106 • (215) 345-4330  
 www.gilmore-assoc.com

*BOROUGH OF BRISTOL*  
 SPECIFICATIONS AND DESIGN STANDARDS  
 250 POND STREET BRISTOL, PA 19007 (215) 788-3828

DATE: OCTOBER 2023  
 NOT TO SCALE  
 DETAIL: 101R

1. THE BRISTOL BOROUGH PUBLIC WORKS SUPERINTENDENT MUST BE NOTIFIED 48 HOURS PRIOR TO ANY STREET OPENING REPAIR TO PROVIDE SUFFICIENT TIME TO SCHEDULE CONSTRUCTION OBSERVATION.
2. NO OPENING MAY BE MADE FOR MORE THAN 200 LINEAR FEET AT ONE TIME, UNLESS AUTHORIZED BY BRISTOL BOROUGH PUBLIC WORKS SUPERINTENDENT.
3. THE EDGES OF THE EXISTING PAVEMENT SHALL BE NEATLY AND CLEANLY CUT TO STRAIGHT LINES. THE EDGES OF THE PAVEMENT SHALL BE NEAT-CUT BACK FROM THE EDGES OF THE TRENCH AT A MINIMUM DISTANCE OF 1 FT ON EACH SIDE.
4. ALL BACKFILLING FOR STREET OPENINGS ARE UNDER THE JURISDICTION OF THE PUBLIC WORKS SUPERINTENDENT AND THE SCHEDULING OF RESTORATION SHALL BE AT HIS DISCRETION.
5. FOR ALL BOROUGH ROADWAYS: THE CONTRACTOR SHALL BACKFILL THE STREET OPENING TRENCH WITH NO. 2A COURSE AGGREGATE THOROUGHLY COMPACTED, PER THE APPROPRIATE PAVEMENT CROSS SECTION FOR BOROUGH ROADS.
6. MILL & OVERLAY: WHERE TRENCH IS CUT LONGITUDINALLY IN TRAVEL LANE(S) OF ROADWAY, FULL WIDTH OF SAID TRAVEL LANE SHALL RECEIVE MILL AND OVERLAY OF WEARING COURSE, ADDITIONALLY:
  - TRENCH RESTORATION FOR ANY ROADWAY WHICH HAS BEEN RESURFACED WITHIN 5 YEARS SHALL INCLUDE MILL AND OVERLAY FOR FULL WIDTH OF THE ROADWAY.
  - WHERE WIDTH OF ROADWAY IS LESS THAN 25 FEET, FULL WIDTH OF ROADWAY SHALL RECEIVE MILL AND OVERLAY.F
  - FOR ALL ROADWAY AND UTILITY OPENINGS LESS THAN 250 SQUARE FEET, THE JOINTS FORMED BETWEEN THE EXISTING PAVEMENT AND THE NEW PAVEMENT SHALL BE SEALED USING INFRARED PAVEMENT RESTORATION AS FOLLOWS:
    - SWEEP THE AREA CLEAN OF ALL DEBRIS.
    - MARK THE AREA TO BE RESTORED A MINIMUM OF 6" BEYOND THE JOINTS FORMED BETWEEN THE EXISTING PAVEMENT AND THE NEW PAVEMENT OR ANY OTHER PAVEMENT DAMAGE.
    - LOWER THE INFRARED HEATER TO THE AREA TO BE RESTORED, EVENLY RAISING THE TEMPERATURE TO SOFTEN THE ASPHALT TO A DEPTH OF 2-3", WITHOUT BURNING THE PAVEMENT.
    - SCARIFY THE PAVEMENT USING AN ASPHALT RAKE TO A DEPTH OF 2".
    - APPLY ASPHALT REJUVENATOR (CYCLOGEN OR APPROVED EQUAL).
    - ADD NEW HOT MIX ASPHALT AS NEEDED TO LEVEL THE REPAIR, RAKING THE AREA SMOOTH AND LEVEL.
    - COMPACT, ROLLING THE EDGES OF THE PATCH FIRST, USING A ROLLER AT 2400 LB/IN<sup>2</sup>.
7. WHERE THERE IS MORE THAN ONE LATERAL TRENCH WITHIN 300 FEET OF ROADWAY, THE ROADWAY SHALL RECEIVE A FULL-WIDTH MILL AND OVERLAY OF WEARING COURSE.
8. EXISTING ROADWAYS ALONG THE FRONTAGE OF THE DEVELOPED PROPERTY SHALL RECEIVE MILL AND OVERLAY OF WEARING COURSE IF ANY OF THE FOLLOWING CONDITIONS ARE NOTED AT THE CONCLUSION OF CONSTRUCTION ACTIVITIES:
  - ALLIGATOR SURFACE, CRACKING OR OTHER DETERIORATION.
  - DIPS, DEPRESSIONS OR OTHER IRREGULARITIES CAUSING PONDING.
  - POT HOLES OR OTHER SURFACE BREAKS.
  - EXCESSIVE SURFACE SCARRING CAUSED BY CONTRACTORS EQUIPMENT (EG. BULLDOZER TRACKS).
9. THE CONTRACTOR SHALL PROTECT ITS OPENINGS TO PROVIDE FOR SAFETY OF THE TRAVELING PUBLIC, INCLUDING MOTORISTS, BICYCLISTS AND PEDESTRIANS.
10. DISTURBED PORTIONS OF A PUBLIC SPACE, INCLUDING BUT NOT LIMITED TO SLOPES, APPURTENANCES AND STRUCTURES SUCH AS GUIDERAIL, CURB, SIGNS, PAVEMENT MARKINGS, DRAIN PIPES, DRIVEWAYS AND VEGETATION, SHALL BE RESTORED TO A CONDITION AT LEAST EQUAL TO THAT WHICH EXISTED BEFORE THE START OF WORK.
11. THE CONTRACTOR WHO PERFORMED THE STREET OPENING REPAIR SHALL BE RESPONSIBLE FOR ITS MAINTENANCE FOR A PERIOD OF 18 MONTHS FROM THE BRISTOL BOROUGH PUBLIC WORKS SUPERINTENDENT'S APPROVAL AND ACCEPTANCE OF THE REPAIR.

## ROADWAY OPENING REPAIR STANDARDS



**GILMORE & ASSOCIATES, INC.**  
**ENGINEERING & CONSULTING SERVICES**  
 65 EAST BUTLER AVENUE, SUITE 100  
 NEW BRITAIN, PA 18901-5106 • (215) 345-4330  
 www.gilmore-assoc.com

*BOROUGH OF BRISTOL*  
 SPECIFICATIONS AND DESIGN STANDARDS  
 250 POND STREET BRISTOL, PA 19007 (215) 788-3828

DATE:	OCTOBER 2023
	NOT TO SCALE
DETAIL:	102R

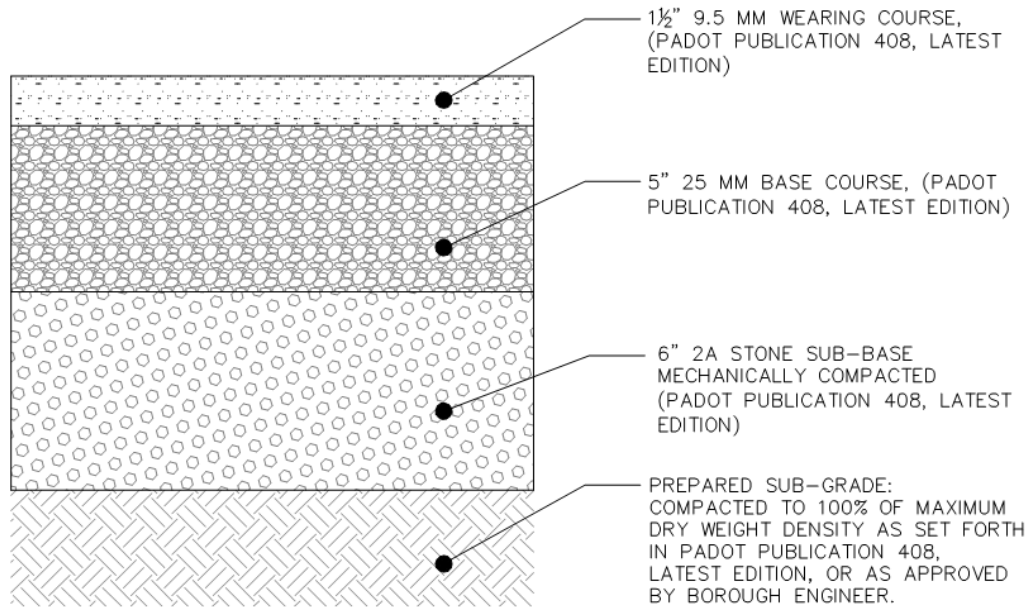

NOTES:

1. ALL CONSTRUCTION SHALL BE IN ACCORDANCE WITH THE SPECIFICATIONS OF PADOT PUBLICATION 408, LATEST EDITION AND COMPLETED IN ACCORDANCE WITH 102R.
2. THE WEARING COURSE THICKNESS INCREASES TO 2" FOR WILSON AVE, BEAVER STREET, JEFFERSON AVENUE, MARKET STREET, OLD ROUTE 13, POND STREET, AND OTTER STREET.
3. FOR ALL ROADS WITH AN EXISTING CONCRETE BASE, A PAVEMENT SECTION DETAIL SHOULD BE APPROVED BY THE BOROUGH ENGINEER.

**PAVEMENT DETAIL FOR BOROUGH ROADS**

**G & A** **GILMORE & ASSOCIATES, INC.**  
**ENGINEERING & CONSULTING SERVICES**  
 65 EAST BUTLER AVENUE, SUITE 100  
 NEW BRITAIN, PA 18901-5106 • (215) 345-4330  
 www.gilmore-assoc.com

*BOROUGH OF BRISTOL*  
 SPECIFICATIONS AND DESIGN STANDARDS  
 250 POND STREET BRISTOL, PA 19007 (215) 788-3828

DATE:	OCTOBER 2023
	NOT TO SCALE
DETAIL:	103R

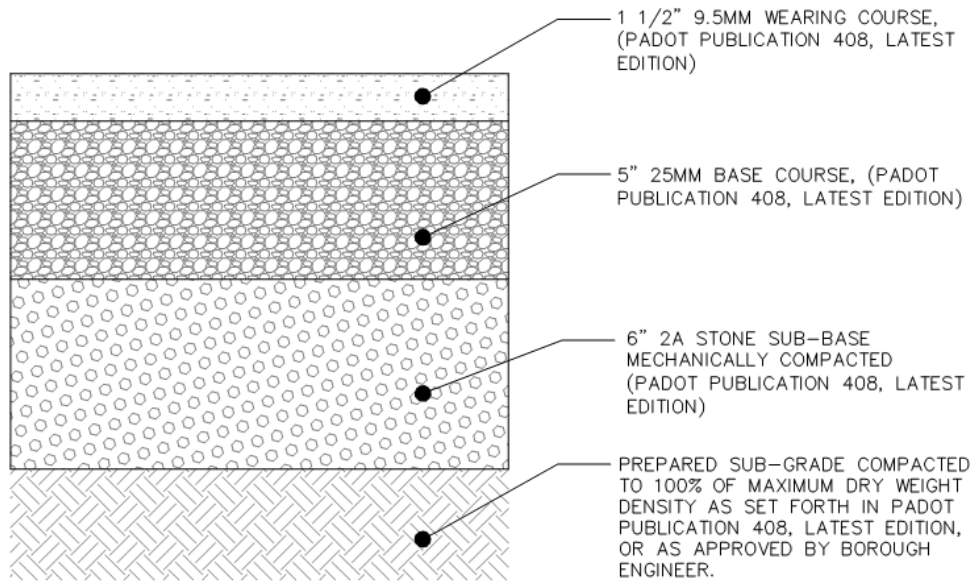

NOTES:

1. SUBGRADE SHALL BE COMPACTED IN ACCORDANCE WITH SPECIFICATIONS OF PADOT PUBLICATION 408, LATEST EDITION. WHERE PARKING AREA(S) ARE TO BE USED FOR INFILTRATION PRACTICES, SUBGRADE SHALL NOT BE COMPACTED AND IT SHALL BE PROTECTED FROM COMPACTION FROM CONSTRUCTION EQUIPMENT, TRAFFIC, STORAGE OF MATERIALS, ETC. TO PRESERVE INFILTRATION CAPACITY OF SUBGRADE SOILS.

**PAVEMENT DETAIL FOR TRUCK TRAFFIC ON DRIVEWAYS AND PARKING LOTS**

**GILMORE & ASSOCIATES, INC.**  
ENGINEERING & CONSULTING SERVICES  
65 EAST BUTLER AVENUE, SUITE 100  
NEW BRITAIN, PA 18901-5108 • (215) 345-4330  
www.gilmore-assoc.com

*BOROUGH OF BRISTOL*  
SPECIFICATIONS AND DESIGN STANDARDS  
250 POND STREET BRISTOL, PA 19007 (215) 788-3828

DATE:	OCTOBER 2023
	NOT TO SCALE
DETAIL:	104R

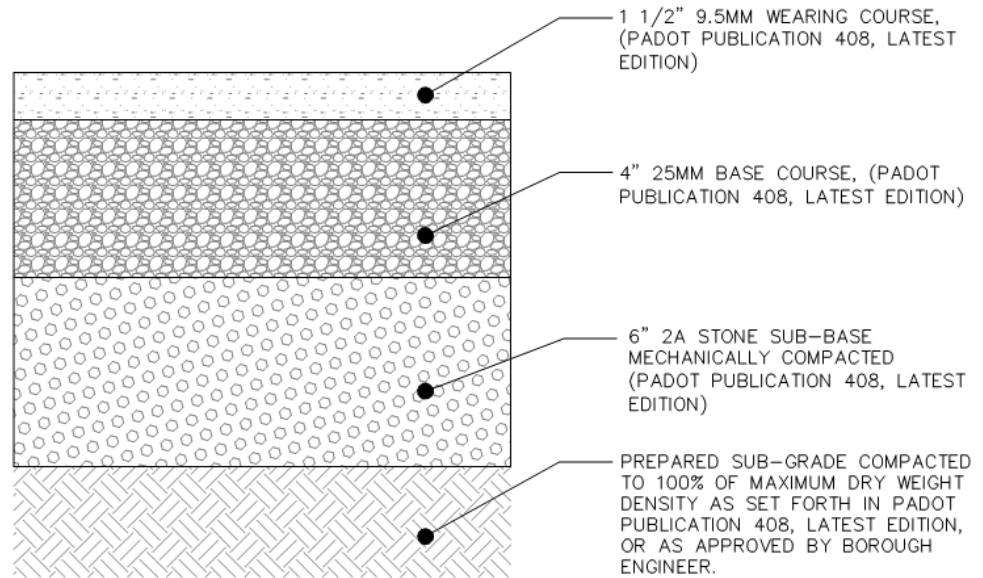

NOTES:

1. SUBGRADE SHALL BE COMPACTED IN ACCORDANCE WITH SPECIFICATIONS OF PADOT PUBLICATION 408, LATEST EDITION. WHERE PARKING AREA(S) ARE TO BE USED FOR INFILTRATION PRACTICES, SUBGRADE SHALL NOT BE COMPACTED AND IT SHALL BE PROTECTED FROM COMPACTION FROM CONSTRUCTION EQUIPMENT, TRAFFIC, STORAGE OF MATERIALS, ETC. TO PRESERVE INFILTRATION CAPACITY OF SUBGRADE SOILS.

**PAVEMENT DETAIL FOR CAR TRAFFIC ONLY ON DRIVEWAYS AND PARKING LOTS**

 <b>GILMORE &amp; ASSOCIATES, INC.</b> ENGINEERING & CONSULTING SERVICES <small>65 EAST BUTLER AVENUE, SUITE 100                  NEW BRITAIN, PA 18901-5109 • (215) 345-4330                  www.gilmore-assoc.com</small>	<b>BOROUGH OF BRISTOL</b> SPECIFICATIONS AND DESIGN STANDARDS 250 POND STREET BRISTOL, PA 19007 (215) 788-3828	DATE: OCTOBER 2023
		NOT TO SCALE
		DETAIL: 105R



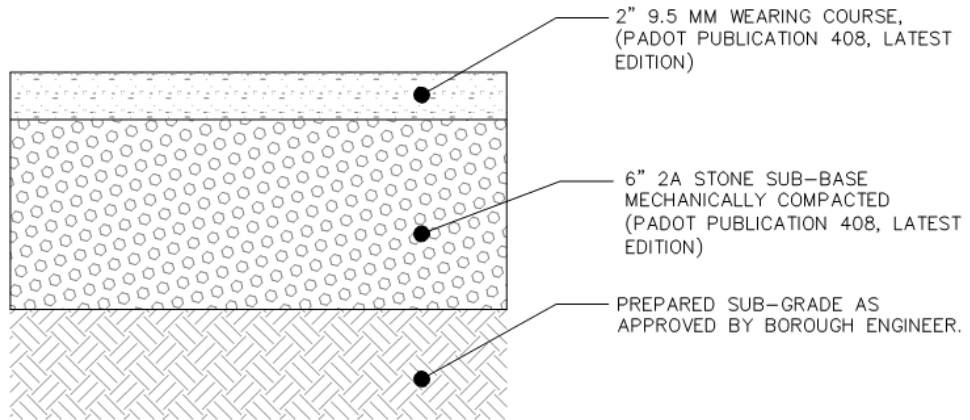

NOTES:

1. SUBGRADE SHALL BE COMPACTED IN ACCORDANCE WITH SPECIFICATIONS OF PADOT PUBLICATION 408, LATEST EDITION. WHERE PARKING AREA(S) ARE TO BE USED FOR INFILTRATION PRACTICES, SUBGRADE SHALL NOT BE COMPACTED AND IT SHALL BE PROTECTED FROM COMPACTION FROM CONSTRUCTION EQUIPMENT, TRAFFIC, STORAGE OF MATERIALS, ETC. TO PRESERVE INFILTRATION CAPACITY OF SUBGRADE SOILS.

**PAVEMENT DETAIL FOR SINGLE-FAMILY RESIDENTIAL DRIVEWAYS**

 <b>GILMORE &amp; ASSOCIATES, INC.</b> <b>ENGINEERING &amp; CONSULTING SERVICES</b> <small>65 EAST BUTLER AVENUE, SUITE 100          NEW BRITAIN, PA 18901-5106 • (215) 345-4330          www.gilmore-assoc.com</small>	<b>BOROUGH OF BRISTOL</b> SPECIFICATIONS AND DESIGN STANDARDS 250 POND STREET BRISTOL, PA 19007 (215) 788-3828	DATE: OCTOBER 2023
		NOT TO SCALE
		DETAIL: 106R

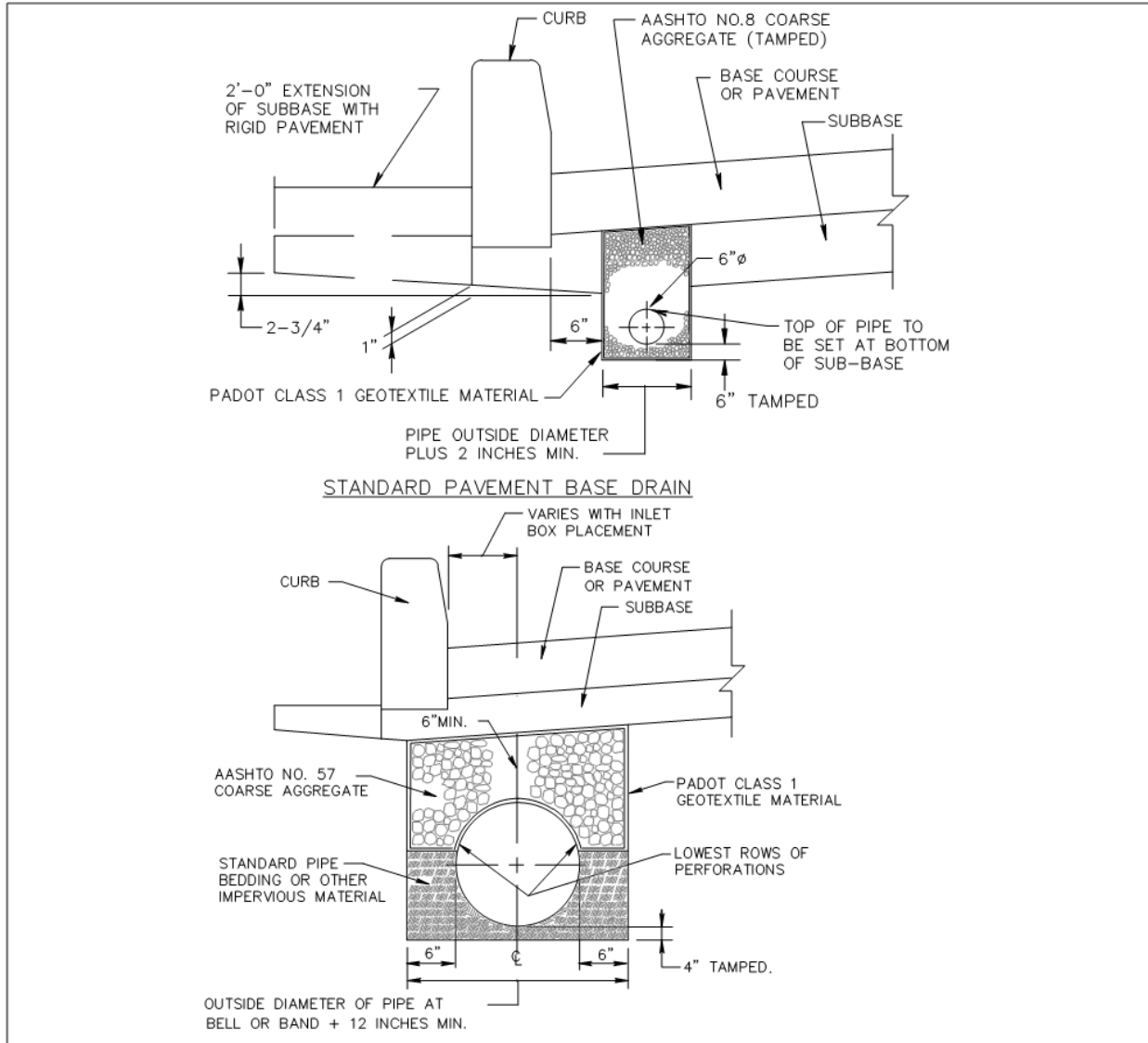

- NOTES:**
1. PROVIDE MATERIALS MEETING REQUIREMENTS OF PADOT SPECIFICATIONS, PUBLICATION 408, LATEST EDITION.
  2. PREFABRICATED PAVEMENT BASE DRAIN IS NOT RECOMMENDED UNDER CURBED SECTIONS OR ADJACENT TO WIDENED PAVEMENT.
  3. PAVEMENT BASE DRAIN SHALL BE BY APPROVAL OF BOROUGH ENGINEER.
  4. USE OF COMBINATION STORM SEWER-UNDERDRAIN SHALL BE BY APPROVAL OF BOROUGH ENGINEER.
  5. ALL CONSTRUCTION SHALL BE IN ACCORDANCE WITH THE SPECIFICATIONS OF PADOT PUBLICATION 408, LATEST EDITION AND COMPLETED IN ACCORDANCE WITH 102R.

**PAVEMENT BASE DRAIN DETAIL**

<b>GILMORE &amp; ASSOCIATES, INC.</b> ENGINEERING & CONSULTING SERVICES <small>65 EAST BUTLER AVENUE, SUITE 100                  NEW BRITAIN, PA 18901-5106 • (215) 345-4330                  www.gilmore-assoc.com</small>	<p><i>BOROUGH OF BRISTOL</i></p> SPECIFICATIONS AND DESIGN STANDARDS 250 POND STREET BRISTOL, PA 19007 (215) 788-3828	DATE: OCTOBER 2023 NOT TO SCALE DETAIL: 107R
---	--	--

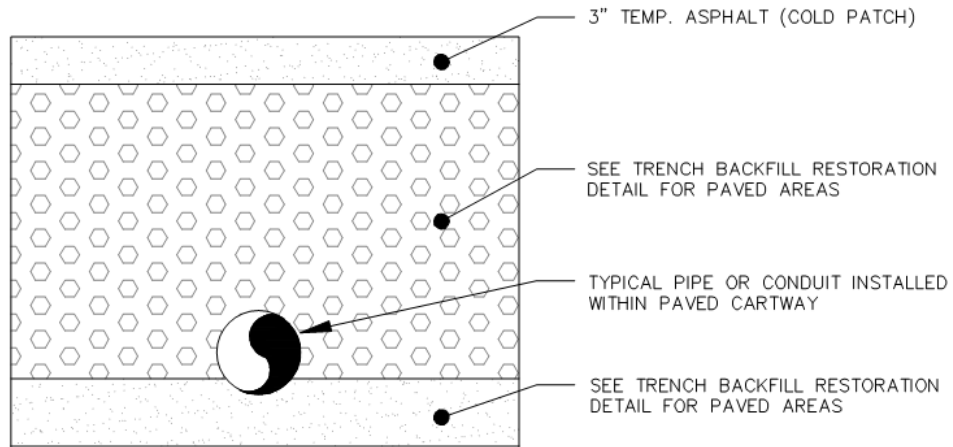

NOTE:  
 TEMPORARY ASPHALT (COLD PATCH) SHALL BE MAINTAINED BY CONTRACTOR UNTIL PERMANENT PAVING RESTORATION IS COMPLETE. TEMPORARY ASPHALT (COLD PATCH) SHALL BE CHECKED AT LEAST ONCE A WEEK AND IMMEDIATELY FOLLOWING MAJOR RAIN, SNOW OR RUNOFF EVENTS. SETTLEMENTS, RUTS, DEPRESSIONS, ETC. IN TEMPORARY ASPHALT SHALL BE CORRECTED BY FILLING THE AREAS WITH ADDITIONAL COLD PATCH AND MECHANICALLY COMPACTING.

**TEMPORARY RESTORATION OF BOROUGH ROADS**

**G & A** **GILMORE & ASSOCIATES, INC.**  
 ENGINEERING & CONSULTING SERVICES  
65 EAST BUTLER AVENUE, SUITE 100  
 NEW BRITAIN, PA 18901-5106 • (215) 345-4330  
 www.gilmore-assoc.com

*BOROUGH OF BRISTOL*  
 SPECIFICATIONS AND DESIGN STANDARDS  
 250 POND STREET BRISTOL, PA 19007 (215) 788-3828

DATE:	OCTOBER 2023
	NOT TO SCALE
DETAIL:	108R

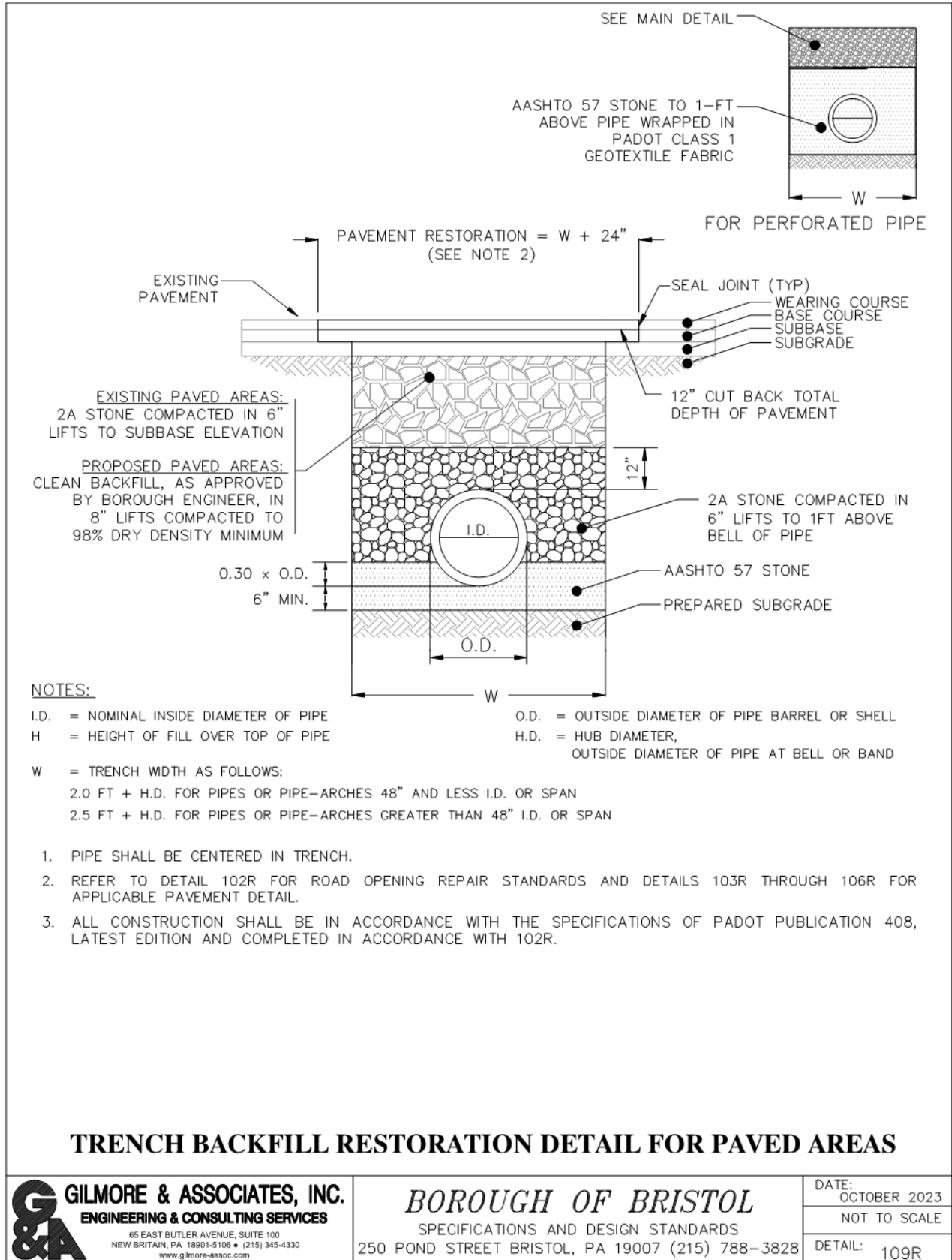

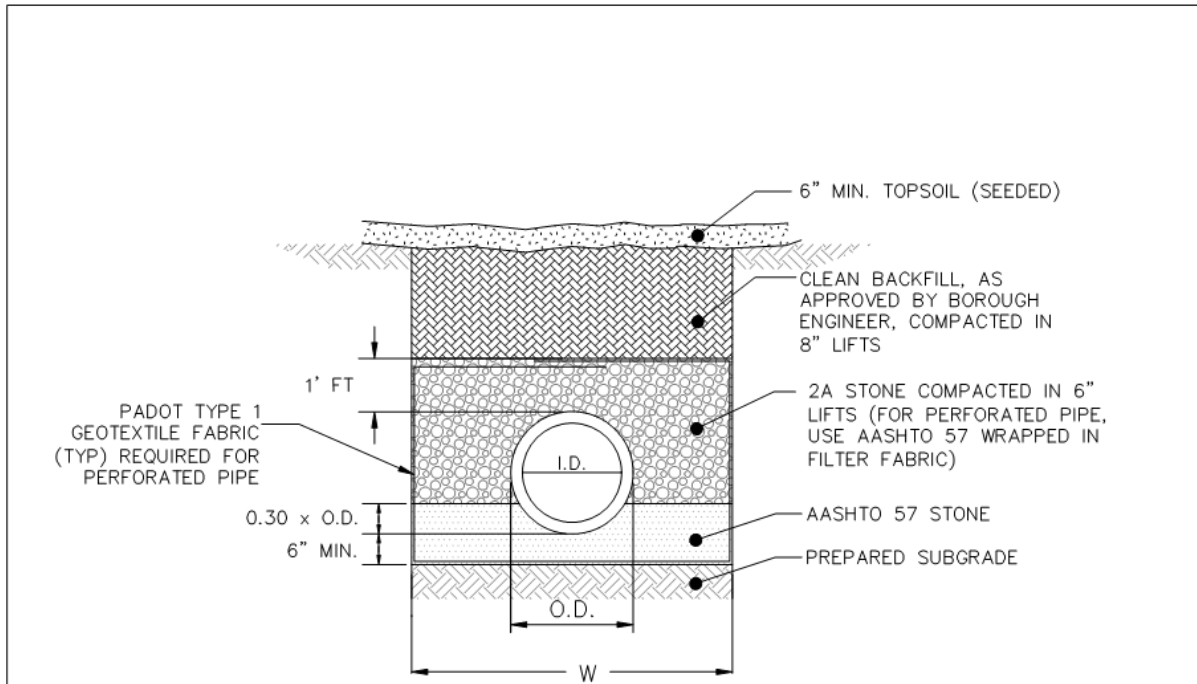

**NOTES:**

- I.D. = NOMINAL INSIDE DIAMETER OF PIPE
- O.D. = OUTSIDE DIAMETER OF PIPE BARREL OR SHELL
- H.D. = HUB DIAMETER, OUTSIDE DIAMETER OF PIPE AT BELL OR BAND
- H = HEIGHT OF FILL OVER TOP OF PIPE
  
- W = TRENCH WIDTH AS FOLLOWS:
  - 2.0 FT + H.D. FOR PIPES OR PIPE-ARCHES 48" AND LESS I.D. OR SPAN
  - 2.5 FT + H.D. FOR PIPES OR PIPE-ARCHES GREATER THAN 48" I.D. OR SPAN
  
- 1. PIPE SHALL BE CENTERED IN TRENCH.

**TRENCH BACKFILL RESTORATION DETAIL FOR NON-PAVED AREAS**

**GILMORE & ASSOCIATES, INC.**  
 ENGINEERING & CONSULTING SERVICES  
65 EAST BUTLER AVENUE, SUITE 100  
 NEW BRITAIN, PA 18901-5108 • (215) 345-4330  
 www.gilmore-assoc.com

*BOROUGH OF BRISTOL*  
 SPECIFICATIONS AND DESIGN STANDARDS  
 250 POND STREET BRISTOL, PA 19007 (215) 788-3828

DATE:	OCTOBER 2023
	NOT TO SCALE
DETAIL:	110R

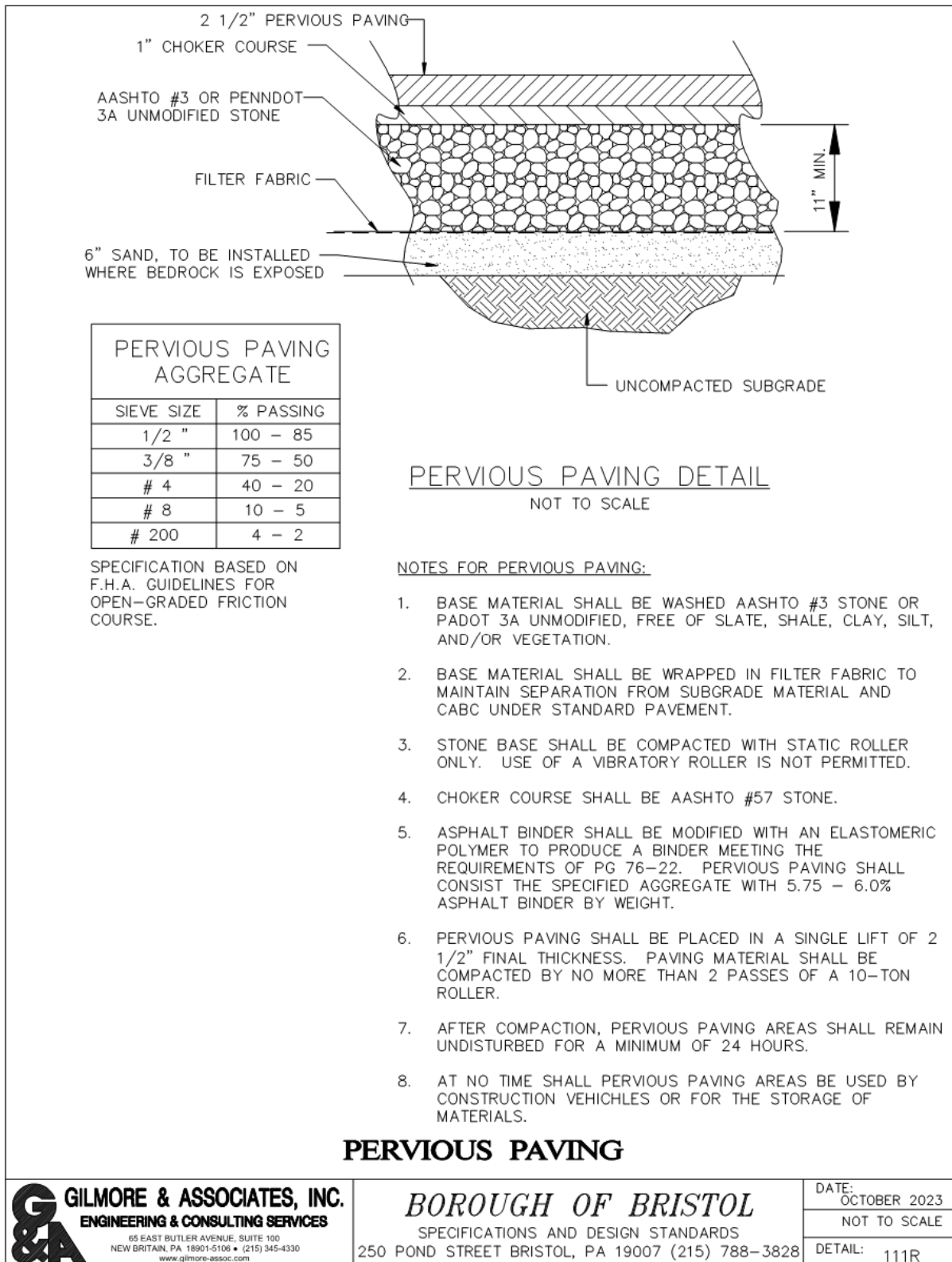

**PERVIOUS PAVING**

**GILMORE & ASSOCIATES, INC.**  
ENGINEERING & CONSULTING SERVICES  
65 EAST BUTLER AVENUE, SUITE 100  
NEW BRITAIN, PA 18901-5106 • (215) 345-4330  
www.gilmore-assoc.com

**BOROUGH OF BRISTOL**  
SPECIFICATIONS AND DESIGN STANDARDS  
250 POND STREET BRISTOL, PA 19007 (215) 788-3828

DATE: OCTOBER 2023  
NOT TO SCALE  
DETAIL: 111R

FUNCTIONAL CLASSIFICATION	INTERSECTION SPACING	CLEAR SIGHT TRIANGLE	MIN. R.O.W. RADIUS	VERTICAL CURVE LENGTH		HORIZONTAL CURVE RADIUS (CENTERLINE)
				CREST, A = 3%/5%/7%	SAG, A = 3%/5%/7%	
ARTERIAL STREET	400'	100'	15'	150'/250'/350'	195'/325'/450'	300' - 850'
COLLECTOR STREET	300'	75'	15'	85'/140'/200'	105'/175'/245'	150' - 300'
LOCAL STREET	300'	50'	15'	50'/75'/105'	60'/100'/140'	300' - 500'

**NOTES:**

1. FUNCTIONAL CLASSIFICATION PER SALDO SECTION 406.2.
2. ALL NEW STREETS SHALL BE PROPERLY POSTED W/SPEED LIMIT SIGNS IN ACCORDANCE WITH DESIGN SPEED.
3. FOR VERTICAL CURVES, A = THE ALGEBRAIC DIFFERENCE IN GRADE BETWEEN TANGENTS.

**INTERSECTION AND ROADWAY ALIGNMENT STANDARDS**



**GILMORE & ASSOCIATES, INC.**  
ENGINEERING & CONSULTING SERVICES  
65 EAST BUTLER AVENUE, SUITE 100  
NEW BRITAIN, PA 18901-5106 • (215) 345-4330  
www.gilmore-assoc.com

*BOROUGH OF BRISTOL*  
SPECIFICATIONS AND DESIGN STANDARDS  
250 POND STREET BRISTOL, PA 19007 (215) 788-3828

DATE:	OCTOBER 2023
	NOT TO SCALE
DETAIL:	112R

**PARKING DIMENSIONS - LONG TERM PARKING**

ANGLE (deg)	STALL WIDTH (PERP TO STALL) (ft)	STALL WIDTH (PARALLEL TO AISLE) (ft)	STALL DEPTH (PERP. TO AISLE) (ft)	STALL LENGTH (PARALLEL TO STALL) (ft)	AISLE - 1 WAY (ft)	AISLE - 2 WAY (ft)	SINGLE BAY WIDTH - 1 WAY (ft)	SINGLE BAY WIDTH - 2 WAY (ft)	DOUBLE BAY WIDTH - 1 WAY (ft)	DOUBLE BAY WIDTH - 2 WAY (ft)
0	8.5	22	22	22	12	22	34	44	56	66
30	8.5	17	16.4	32.8	12	NA	28.4	NA	44.8	NA
45	8.5	12.1	18.8	26.6	14	NA	32.8	NA	51.6	NA
60	8.5	9.9	19.9	23	18	NA	37.9	NA	57.8	NA
90	8.5	9	18	18	22	22	40	40	58	58

**PARKING DIMENSIONS - SHORT TERM PARKING**

ANGLE (deg)	STALL WIDTH (PERP TO STALL) (ft)	STALL WIDTH (PARALLEL TO AISLE) (ft)	STALL DEPTH (PERP. TO AISLE) (ft)	STALL LENGTH (PARALLEL TO STALL) (ft)	AISLE - 1 WAY (ft)	AISLE - 2 WAY (ft)	SINGLE BAY WIDTH - 1 WAY (ft)	SINGLE BAY WIDTH - 2 WAY (ft)	DOUBLE BAY WIDTH - 1 WAY (ft)	DOUBLE BAY WIDTH - 2 WAY (ft)
0	9	22	22	22	12	22	34	44	56	66
30	9	18	16.8	33.6	12	NA	28.8	NA	45.6	NA
45	9	12.8	19.2	27.1	14	NA	33.2	NA	52.4	NA
60	9	10.4	20.1	23.2	18	NA	38.1	NA	58.2	NA
90	9	9	18	18	22	22	40	40	58	58

**NOTE**

1. Short Term Parking applies to residential, commercial, retail and institutional uses.
2. Long term parking applies to commuter parking, employee parking.
3. The final determination of long vs short term parking is entirely at the discretion of Borough Council.
4. ADA requirements apply for accessible spaces.

**PARKING STALL AND AISLE DIMENSIONS**



**GILMORE & ASSOCIATES, INC.**  
ENGINEERING & CONSULTING SERVICES  
65 EAST BUTLER AVENUE, SUITE 100  
NEW BRITAIN, PA 16901-5106 ■ (215) 345-6330  
www.gilmore-essoc.com

*BOROUGH OF BRISTOL*  
SPECIFICATIONS AND DESIGN STANDARDS  
250 POND STREET BRISTOL, PA 19007 (215) 788-3828

DATE:	OCTOBER 2023
	NOT TO SCALE
DETAIL:	11.3R



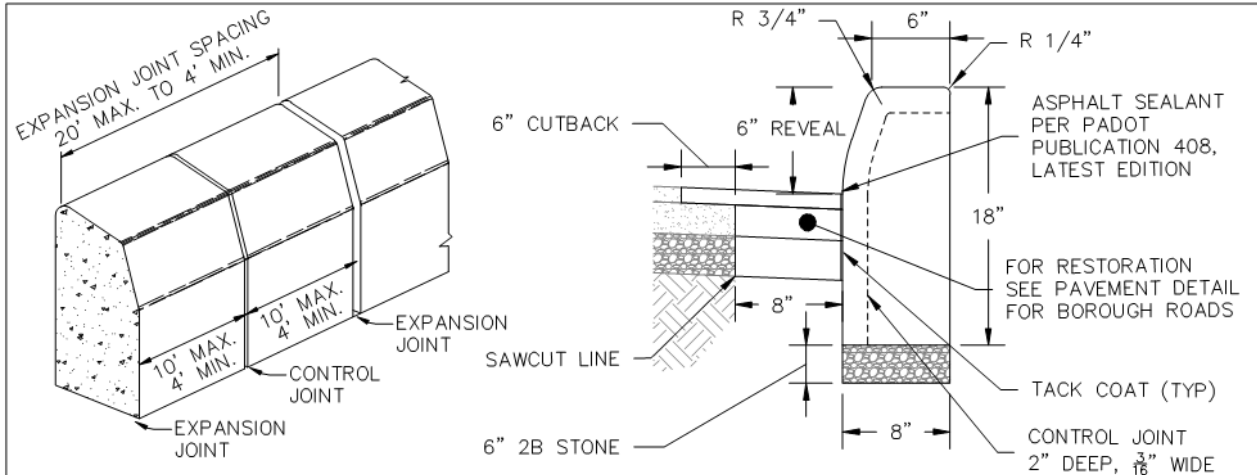

**INSTALLATION NOTES:**

1. TAPERED CURB IS TO BE USED WHEN EXISTING CURB BEING REPLACED IS TAPERED OR NEW CURB IS BEING INSTALLED. ALL OTHER EXISTING CURBS TO BE NON-TAPERED.
2. ALL CONCRETE TO BE CLASS A FROM PADOT APPROVED SUPPLIER.
3. ALL CONSTRUCTION AND MATERIALS SHALL CONFORM WITH PADOT PUBLICATION 408, LATEST EDITION.
4. EXISTING ROAD SURFACE TO BE SAWCUT ALONG CURB NO MORE THAN 8" MAXIMUM FROM CURB FACE.
5. EXPANSION JOINTS SHALL BE PLACED AT A MAXIMUM INTERVAL OF 20 FEET, AT THE END OF EVERY DAY, AND ON BOTH SIDES OF ALL STRUCTURES. JOINTS SHALL BE 1/2" THICK PRE-MOLDED MATERIAL.
6. INTERMEDIATE CONTROL JOINTS TYPICAL 2" DEEP X 3/16" WIDE. JOINTS TO BE PLACED AT 10' INTERVALS (MIN. OF 4' FOR CLOSURE OR CURVES).
7. TACK COAT EXISTING PAVEMENT AND ALL VERTICAL SURFACES BELOW PAVING LINE. IF BASE COURSE IS IN PLACE FOR MORE THAN 30 DAYS, THE SURFACE MUST BE CLEANED AND TACK COATED PRIOR TO INSTALLATION OF WEARING COURSE.
8. ALL ASPHALT JOINTS INCLUDING ALONG THE CURBLINE SHALL BE SEALED IN ACCORDANCE WITH 102R.
9. ALL CURB FORMS MUST BE APPROVED BY THE BOROUGH ENGINEER. ALL SLIP FORM CONSTRUCTION SHALL BE OBSERVED BY THE BOROUGH ENGINEER.

**CURB EVALUATION CRITERIA** – WHEN EVALUATING CURB FOR REPLACEMENT, IF ONE OF THE APPEARANCE OR MISALIGNMENT CONDITIONS LISTED BELOW EXISTS, THE CURB IS MARKED FOR REPLACEMENT.

1. MISSING CURB.
2. EVIDENCE OF DETERIORATED CONDITION AND/OR SECTIONS ARE LOOSE OR GONE.
3. DIAGONAL CRACKS.
4. MULTIPLE VERTICAL CRACKS IN A 10-FT SECTION. A SINGLE VERTICAL CRACK CAN BE SAW-CUT IF THEY APPEAR TO BE OLD STRESS CRACKS.
6. CHIPS LARGER THAN 2" ACROSS AND 1/4" DEEP.
7. CURB THAT HAS BEEN PATCHED OR CAPPED WITH CONCRETE.
8. CURB THAT HAS BEEN ALTERED BY HOMEOWNER. THIS MAINLY OCCURS AT DRIVEWAYS.
9. SIDEWALKS, DRIVEWAY APRONS, AND DRIVEWAY DEPRESSIONS THAT HAVE BEEN PAVED OVER WITH ASPHALT.
10. THE CURB HAS DROPPED OR RAISED AND THE TOP IS MISALIGNED MORE THAN 1/4".
11. THE CURB IS LEANING FORWARD TOWARDS THE ROAD SURFACE OR BACK TO THE GRASS STRIP AND IS MISALIGNED MORE THAN 1/4" ALONG THE VERTICAL JOINT.
12. IF THE CURB HAS BEEN PUSHED AND IS MISALIGNED BY MORE THAN 1/4".
13. TOP OF CURB AND FACE OF CURB SHALL BE FREE OF SURFACE DEFECTS. (I.E. HONEY COMB).

**CURB REPLACEMENT STANDARDS**

1. THE SHORTEST SECTION OF CURB TO BE REPLACED IS 5 FEET.
2. THE EXISTING ROADWAY IS TO BE SAW CUT & FULL FORMS ARE TO BE USED ON THE FACE OF CURB.
3. MONOLITHIC POURS OF CURB & DRIVEWAY APRON ARE NOT PERMITTED.
4. EXPANSION MATERIAL IS REQUIRED TO BE PLACED AGAINST THE EXISTING CONCRETE.

**STANDARD CONCRETE CURB FOR NON-PADOT APPLICATIONS**

**GILMORE & ASSOCIATES, INC.**  
**ENGINEERING & CONSULTING SERVICES**  
 65 EAST BUTLER AVENUE, SUITE 100  
 NEW BRITAIN, PA. 18901-5106 • (215) 345-4330  
 www.gilmore-assoc.com

**BOROUGH OF BRISTOL**  
 SPECIFICATIONS AND DESIGN STANDARDS  
 250 POND STREET BRISTOL, PA 19007 (215) 788-3828

DATE: OCTOBER 2023  
 NOT TO SCALE  
 DETAIL: 200C

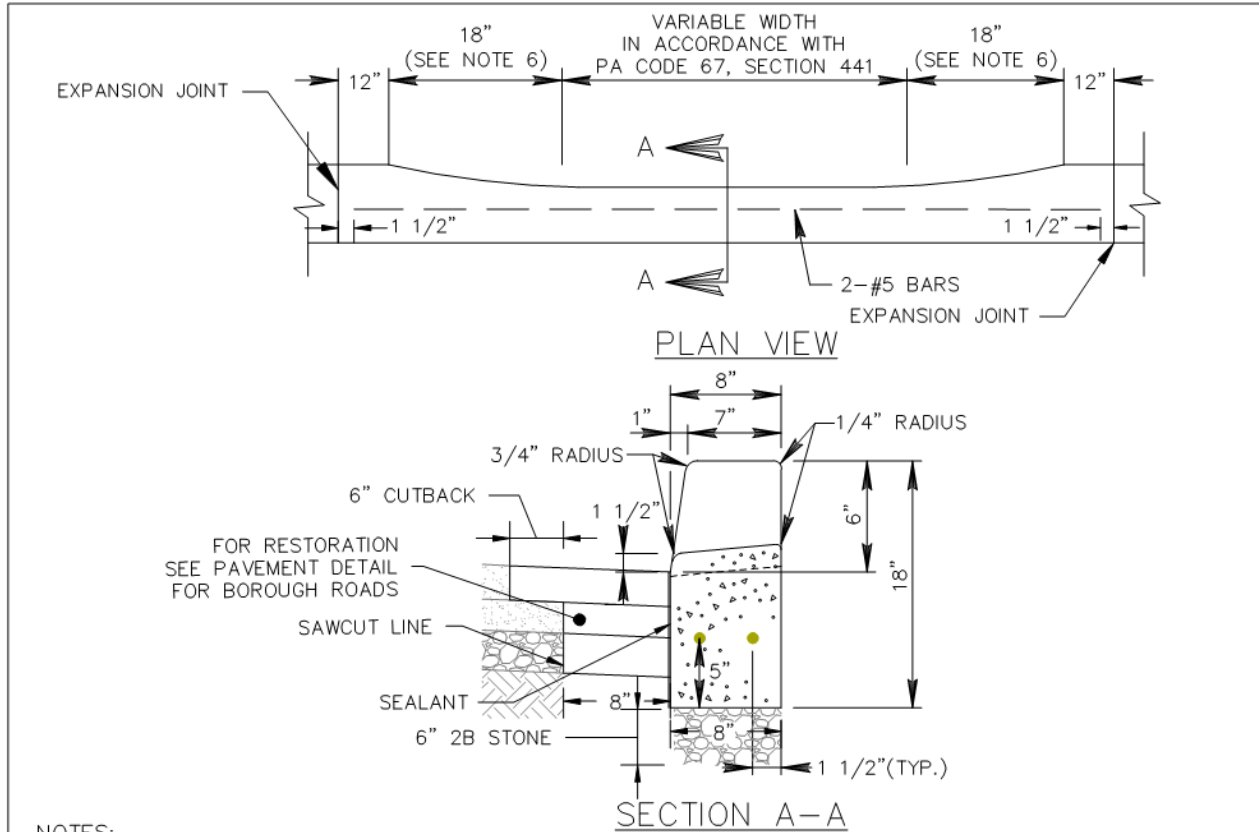

**NOTES:**

1. TAPERED CURB IS TO BE USED WHEN EXISTING ADJACENT CURB IS TAPERED OR NEW CURB IS BEING INSTALLED. ALL OTHER EXISTING CURBS TO BE NON-TAPERED.
2. ALL CONCRETE TO BE CLASS A FROM PADOT APPROVED SUPPLIER.
3. ALL CONSTRUCTION AND MATERIALS SHALL CONFORM WITH PADOT PUBLICATION 408, LATEST EDITION AND COMPLETED IN ACCORDANCE WITH 102R.
4. EXISTING ROAD SURFACE TO BE SAWCUT ALONG CURB, NO MORE THAN 8" WIDTH.
5. INTERMEDIATE CONTROL JOINTS TYPICAL 2" DEEP X 3/16" WIDE. JOINTS TO BE PLACED AT 10' INTERVALS (MIN. OF 4' FOR CLOSURE OR CURVES).
6. A TRANSITION LENGTH OF 18 INCHES IS NOT ACCEPTABLE FOR LOCATIONS WITHOUT GRASS STRIP BETWEEN CURB & SIDEWALK. TRANSITION LENGTH SHALL BE INCREASED TO 3 FEET OR AS MAY BE NECESSARY TO PROVIDE AN ACCESSIBLE SIDEWALK MEETING ADA REQUIREMENTS.
7. PLACE 2" DEEP, 3/16" WIDE CONTROL JOINTS IN TOP OF DEPRESSED CURB IN UNIFORM SPACING OF 10' MAX.
8. PLACE 1/2" PREMOLDED EXPANSION JOINT FILLER ADJACENT TO CURB OR TO CONFORM TO CROSS SECTIONAL MATERIAL AT STRUCTURES AND AT THE END OF THE WORK DAY. CUT MATERIAL TO CONFORM TO AREA OF CURB.
9. SEE RC-50 FOR PLAIN CONCRETE CURB SLOPED TOP TREATMENT AT END OF STRUCTURES.
10. EXPANSION JOINTS ARE NOT PERMITTED THROUGH REINFORCEMENT BARS. END REINFORCEMENT BARS 1 1/2" FROM EXPANSION JOINTS.
11. ALL CURB FORMS MUST BE APPROVED BY THE BOROUGH ENGINEER.

**DEPRESSED CONCRETE CURB FOR DRIVEWAYS**

**GILMORE & ASSOCIATES, INC.**  
ENGINEERING & CONSULTING SERVICES  
65 EAST BUTLER AVENUE, SUITE 100  
NEW BRITAIN, PA 18901-5106 • (215) 345-4330  
www.gilmore-assoc.com

*BOROUGH OF BRISTOL*  
SPECIFICATIONS AND DESIGN STANDARDS  
250 POND STREET BRISTOL, PA 19007 (215) 788-3828

DATE: OCTOBER 2023  
NOT TO SCALE  
DETAIL: 201C

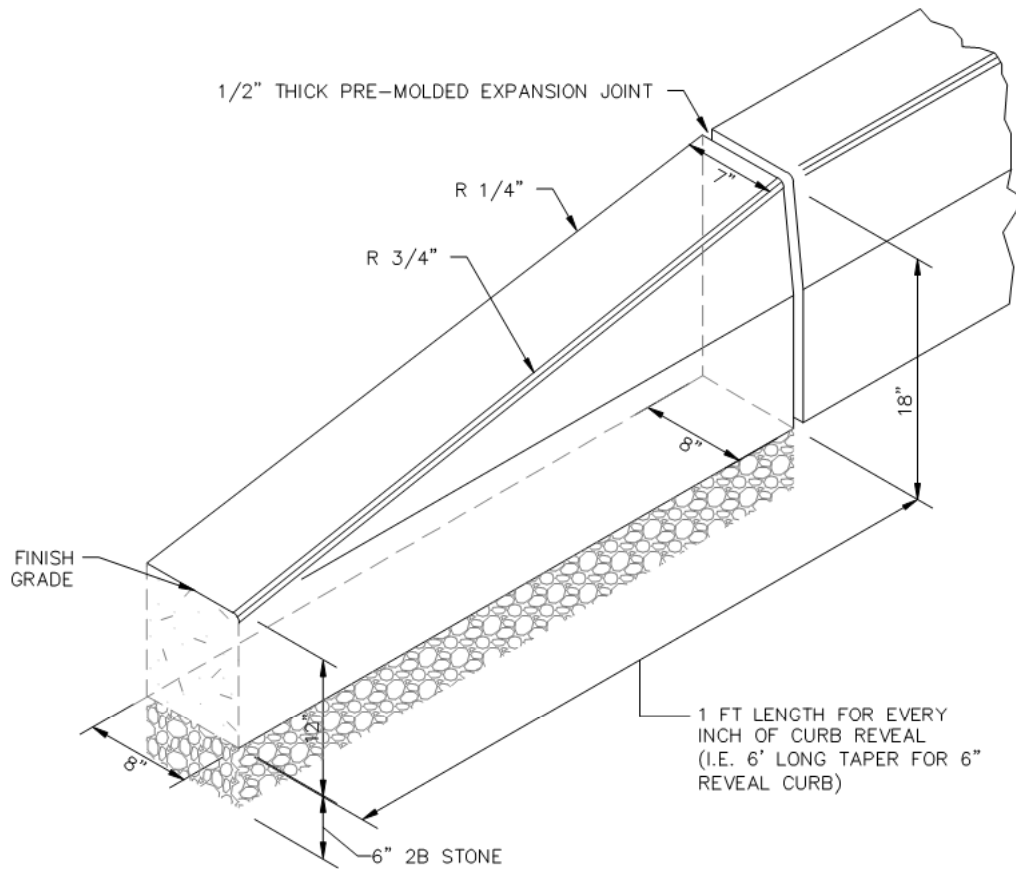

NOTE:

1. ALL CONSTRUCTION AND MATERIALS SHALL CONFORM WITH PADOT PUBLICATION 408, LATEST EDITION.
2. ALL CONCRETE TO BE CLASS A FROM PADOT APPROVED SUPPLIER.
3. ALL CURB FORMS MUST BE APPROVED BY THE BOROUGH ENGINEER.

**TAPERED CONCRETE CURB FOR NON-PADOT APPLICATIONS**

**GILMORE & ASSOCIATES, INC.**  
**ENGINEERING & CONSULTING SERVICES**  
 65 EAST BUTLER AVENUE, SUITE 100  
 NEW BRITAIN, PA 18901-5106 • (215) 345-4330  
 www.gilmore-assoc.com

*BOROUGH OF BRISTOL*  
 SPECIFICATIONS AND DESIGN STANDARDS  
 250 POND STREET BRISTOL, PA 19007 (215) 788-3828

DATE:	OCTOBER 2023
	NOT TO SCALE
DETAIL:	202C

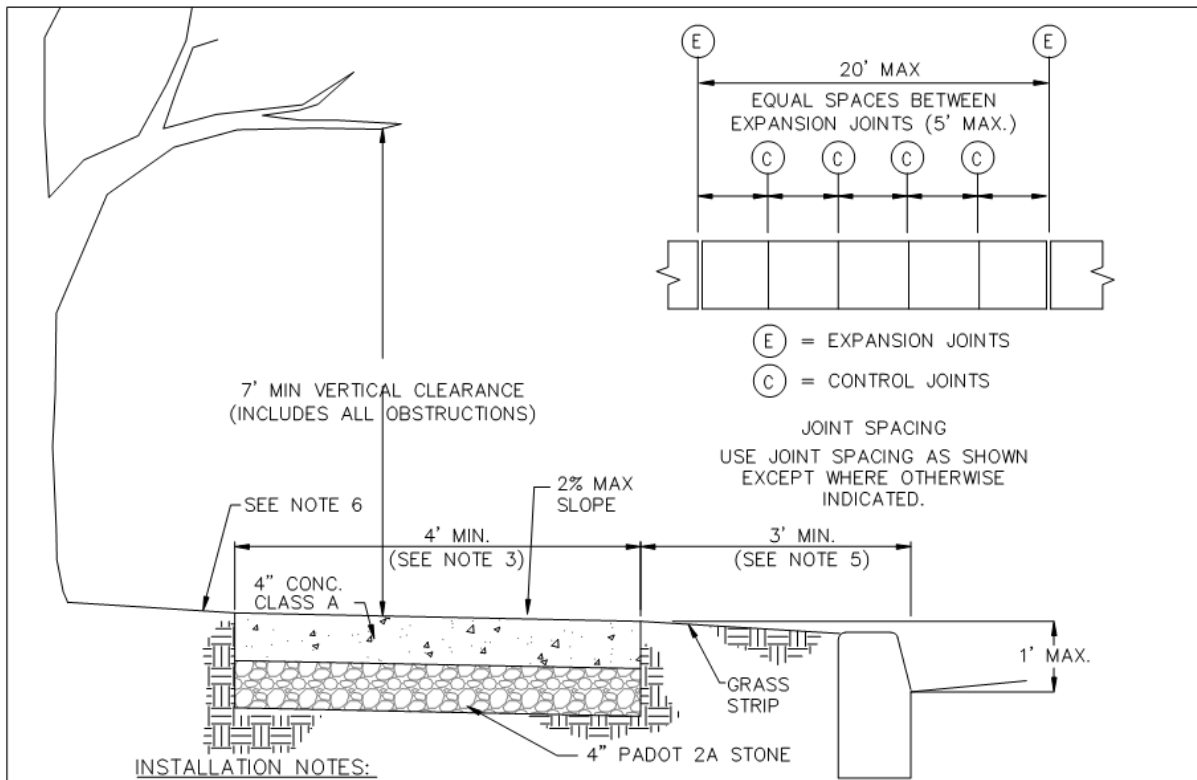

**INSTALLATION NOTES:**

1. ALL CONSTRUCTION AND MATERIALS TO CONFORM WITH PADOT PUBLICATION 408, LATEST EDITION.
2. INSTALLATION OF CURB RAMPS FOR ACCESSIBILITY SHALL MEET ADA REQUIREMENTS AND SHALL BE IN ACCORDANCE WITH PADOT DETAILS RC-67, LATEST EDITION. PADOT DETAILS ARE INCLUDED HEREWITH BY REFERENCE.
3. BOROUGH COUNCIL MAY REQUIRE ADDITIONAL WIDTH IN AREAS WHERE HIGHER VOLUMES OF PEDESTRIAN TRAFFIC ARE ANTICIPATED.
4. SIDEWALK SHALL NOT EXTEND BEYOND THE RIGHT-OF-WAY (NEW CONSTRUCTION) UNLESS EASEMENTS ARE PROVIDED AND SHALL NOT INTERFERE WITH MONUMENTS AND PINS. REFER TO NOTE 4 OF DETAIL 100R TYPICAL ROADWAY SECTION FOR BOROUGH ROADS.
5. WHERE EXISTING SIDEWALK ABUTS CURB, SURFACES SHALL BE FLUSH AND SHALL BE SEPARATED BY A 1/2" PREMOLDED EXPANSION JOINT.
6. TRIM ROOTS AND INSTALL ROOT BARRIER IN ACCORDANCE WITH "ROOT PRUNING" AND "ROOT BARRIER" STANDARDS AS NEEDED.
7. ALL CONCRETE TO BE CLASS A FROM PADOT APPROVED SUPPLIER.
8. 1/2" PREMOLDED EXPANSION JOINTS SHALL BE PLACED EVERY THIRTY (30) FEET MAX WITH CONTROL JOINTS EVERY FIVE (5) FEET MAX AND A MINIMUM OF ONE (1) INCH IN DEPTH.
9. BROOM FINISH FOR NON-SLIP SURFACE.
10. THIS STANDARD IS NOT INTENDED FOR SIDEWALK WHICH CROSSES A DRIVEWAY.

**SIDEWALK REPAIR AND REPLACEMENT STANDARDS:**

1. SIDEWALKS SHALL BE REPLACED WHEN THE FOLLOWING CONDITIONS OCCUR:
  - A. EVIDENCE OF DETERIORATED CONDITION.
  - B. SECTIONS WITH VERTICAL MISALIGNMENTS GREATER THAN 1/4" WITH WALKABLE SURFACES.

**CONCRETE SIDEWALK INSTALLATION**

**GILMORE & ASSOCIATES, INC.**  
 ENGINEERING & CONSULTING SERVICES  
 65 EAST BUTLER AVENUE, SUITE 100  
 NEW BRITAIN, PA 18901-5106 • (215) 345-4330  
 www.gilmore-assoc.com

**BOROUGH OF BRISTOL**  
 SPECIFICATIONS AND DESIGN STANDARDS  
 250 POND STREET BRISTOL, PA 19007 (215) 788-3828

DATE: OCTOBER 2023  
 NOT TO SCALE  
 DETAIL: 203C

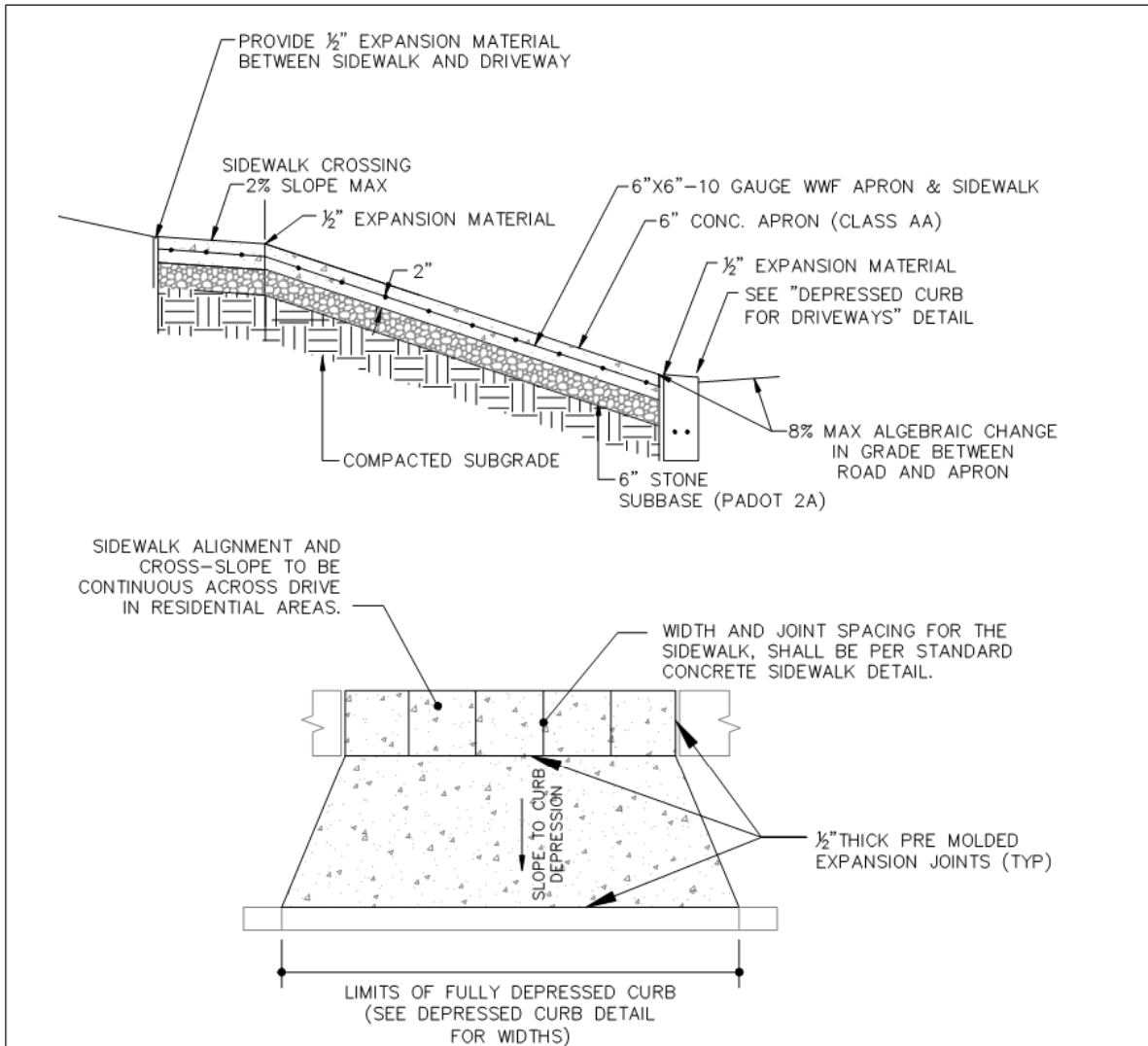

**INSTALLATION NOTES:**

1. ALL CONSTRUCTION AND MATERIALS TO CONFORM WITH PADOT PUBLICATION 408, LATEST EDITION.
2. ALL CONCRETE TO BE CLASS AA FROM PADOT APPROVED SUPPLIER.
3. ALL DRIVEWAYS OR APRONS CONSTRUCTED ADJACENT TO CURB SHALL HAVE DEPRESSED CURB INSTALLED IN ACCORDANCE WITH THE DEPRESSED CONCRETE CURB FOR DRIVEWAYS DETAIL.

**DRIVEWAY APRON REPLACEMENT STANDARDS** – DRIVEWAY APRONS SHALL BE REPLACED WHEN THE FOLLOWING CONDITIONS OCCUR:

1. EVIDENCE OF DETERIORATED CONDITION.
2. APRONS PLACED WITH VERTICAL MISALIGNMENT OF 1/4" HIGHER OR LOWER THAN REQUIRED DEPRESSED CURB HEIGHT.

**CONCRETE APRON FOR DRIVEWAY CROSSINGS**

 <p><b>GILMORE &amp; ASSOCIATES, INC.</b> ENGINEERING &amp; CONSULTING SERVICES 65 EAST BUTLER AVENUE, SUITE 100 NEW BRITAIN, PA 18901-5106 • (215) 345-4330 www.gilmore-assoc.com</p>	<p><i>BOROUGH OF BRISTOL</i> SPECIFICATIONS AND DESIGN STANDARDS 250 POND STREET BRISTOL, PA 19007 (215) 788-3828</p>	DATE: OCTOBER 2023
		NOT TO SCALE
		DETAIL: 204C

**SECTION 34 41 16**  
**TRAFFIC SIGNAL SPECIFICATIONS**

1. General

- 1.1. All construction methods and materials shall be in accordance with these specifications and in accordance with the latest revised editions of Pennsylvania Department of Transportation "Specifications Pub. 408/2011", PennDOT Pub. No. 148, "Traffic Standards - Signals; TC-8800 Series", PennDOT Pub. No. 111M, "Traffic Control Signing Standards; TC-8700 Series", Penn DOT Pub No 72M "Roadway Construction Standards," (Latest Editions).
- 1.2. The CONTRACTOR shall furnish every one of the materials and workmanship specified herein, and every single one of the miscellaneous materials, equipment, and labor as may be required to accomplish the traffic signal installations in accordance with each PennDOT permit.
- 1.3. All material, equipment and workmanship provided by the CONTRACTOR shall be of good quality, new, and guaranteed for a period of one (1) year following acceptance of the project by the OWNER, except as otherwise provided by manufacturers in the Contract Documents.
- 1.4. The CONTRACTOR must be PennDOT prequalified for traffic signal installations. The CONTRACTOR's personnel must be International Municipal Signal Association, Inc. (I.M.S.A.) certified to Level 1 at a minimum and managed by Level 2 at a minimum. Furnish certificate with bid documents.
- 1.5. Bidders shall submit catalog information with bid documents for each and every material that has a provisional certificate of approval with PennDOT. The successful bidder shall submit catalog cuts and/or shop drawings on each and every one of the materials for approval by the OWNER. The bidder shall supply the manufacturer's name and model number and PennDOT certificate of approval number for traffic signal equipment on the appropriate form of the Bid.
- 1.6. The CONTRACTOR is reminded of his obligations under the provisions of Act 287 to contact the appropriate utilities in advance of every excavation operation. The CONTRACTOR shall carefully support and protect from damage, each and every one of the existing utilities that may be encountered during the performance of the work under this contract. The Pennsylvania One Call System 1-800-242-2776 must be used. It is the CONTRACTOR's responsibility to determine what utilities exist at the work site and to verify subsurface conditions.
- 1.7. The CONTRACTOR shall review the project site prior to initiating work and shall meet with representatives of every affected utility company to determine types and location of utility facilities. Should utility facilities interfere with the placement of or visibility of official traffic control devices as proposed herein and shown on the drawings, the CONTRACTOR shall coordinate the adjustment of utility facilities to the satisfaction of the OWNER.
- 1.8. The CONTRACTOR shall provide an emergency service phone number(s) and a minimum of two (2) competent and reliable persons who are delegated to be readily available on a 24-hour basis, and have authority to act in the behalf of the CONTRACTOR in case it is necessary to respond to each and every emergency situations in four (4) hours or less, which may arise in connection with the project during off working hours, evenings and holidays.
- 1.9. In order to establish a standard for equipment on this and every future project, certain manufactures may have been selected. This selection is based upon the quality of their products, level of support, warranties and past performance.

- 1.10. No concrete shall be poured until the excavation, rebar, anchor bolts, and forms are examined by the ENGINEER. The CONTRACTOR shall provide a minimum twenty-four (24) hour prior notice to the ENGINEER.
  - 1.11. The CONTRACTOR shall trim each and every tree and remove brush necessary for the clear and unobstructed view of the traffic signal installation. Where doubt exists, the CONTRACTOR shall consult the ENGINEER, and the decision of the ENGINEER will be final.
2. Project Description
    - 2.1. This project consists of the installation and/or modernization or upgrade of Traffic Signals and/or Flashing Warning Devices within Bristol Borough, Bucks County, PA as shown on the approved Traffic Signal Permit Plans. The CONTRACTOR shall furnish and install the traffic signal supports, signal heads, controller assembly, electrical distribution system, and signs described herein and indicated on the drawings. It is the intent of these specifications to describe a comprehensive and working traffic signal system. Accessories, hardware, brackets, clamps and other devices not specifically mentioned, but otherwise required shall be furnished and installed by the CONTRACTOR to accomplish the work.
3. Pre-Construction Meeting
    - 3.1. It shall be the responsibility of the Contractor to arrange a preconstruction meeting onsite with the Pennsylvania Department of Transportation (PennDOT) Traffic Unit and the Borough Engineer and Borough Staff to spot signal poles, curb ramps, controller cabinet pad, and vehicle detector locations in the field. No work may begin until this meeting has been held and the intended scope of the signal installation is satisfactory to all parties.
    - 3.2. Once work has begun, the Contractor shall be responsible for notifying the Borough Engineer 24 hours prior to the following, so that a representative of the Borough may be onsite to inspect the following work:
      - Installation of signal pole foundations and/or islands before concrete is placed;
      - Trenching and conduit installation before backfilling occurs;
      - Saw cutting for loop detector installation before sealing;
      - Installation of loop detector wire, prior to sealing;
      - Installation of ADA Approved Curb Ramps
      - Completion of earth ground resistance testing of each foundation as per PENNDOT Form 408, Section 954.3.(I);
      - Completion of loop detector series, inductance, and resistance testing in accordance with PENNDOT Publication 408 before splices are sealed within the junction box;
    - 3.3. Contractor shall test all standard inductance loop detectors and ground rods in the presence of the Owner and/or Engineer. The resistance to earth ground of the controller cabinet shall be less than 15 ohms (not bonded) and the resistance to earth ground of the signal support poles shall be less than 25 ohms (not bonded).
    - 3.4. Contractor shall test all switches and push buttons located within the switch compartment in the presence of the Owner and/or Engineer.
    - 3.5. Contractor shall perform Bidirectional Power Meter/Light Source testing at all fiber termination points in the presence of the Owner and/or Engineer.
    - 3.6. Work not inspected and/or completed to the satisfaction of the Borough Engineer and/or Borough Staff shall be redone by the Contractor at the direction of the Borough Engineer and/or Borough Staff.

#### 4. Maintenance and Protection of Traffic

- 4.1. Maintenance and protection of pedestrian and vehicular traffic shall be strictly observed by the Contractor in completing the project work program, as follows:
- 4.1.1. All workers must wear an ANSI Certified Type II (or better) reflective vest or other appropriate safety apparel during working hours.
  - 4.1.2. The Contractor must provide vehicles outfitted with safety beacons, appropriate traffic control signing, barricades, flags and cones.
  - 4.1.3. All work must be done in compliance with the contract drawings and the appropriate figures contained within the MUTCD and/or Publication 213, Work Zone Traffic Control Manual, published by the Pennsylvania Department of Transportation.
  - 4.1.4. Open trenches across travel lanes are not permitted during nonworking hours unless, on the approval of the ENGINEER, such trenches are safely decked with steel plates of sufficient size and strength to support the traffic load. The steel plates shall be pinned into the existing surrounding roadway or sealed with asphalt along both intersecting roadway surfaces. The Contractor's name and emergency telephone number shall be painted and legible on each plate to assist the Borough in the event of an emergency.
  - 4.1.5. All travel lanes must be open for traffic during the morning (6 a.m. - 9 a.m.) and evening peak hours (3 p.m. - 7 p.m.). Two-way traffic must be maintained at all times. Lane closures are permitted for short periods if flagging is provided in accordance with the MUTCD and/or PENNDOT Publication 213, "Work Zone Traffic Control Manual." All stated times are local prevailing times.
- 4.2. Pedestrian movements shall be protected by the use of proper barricades, lights, signs, and pedestrian warning devices.
- 4.3. At no time shall the CONTRACTOR's work cause the roadway to be totally closed. During periods of single lane shutdown, the CONTRACTOR shall have flagmen direct traffic in accordance with Publication 213. Time provisions as stated in section 4.1.5 shall apply to single lane shutdown.

#### 5. Portland Cement Concrete

- 5.1. For traffic signal and sign support foundations and equipment cabinet base, use Class A conforming to PENNDOT Section 704 and as follows:
- The foundation depth for each traffic signal mast arm shall be as stated in PENNDOT Publication 148, TC8800 Series.
  - Contractor shall not install poles on concrete bases until a minimum of 72 hours after placing concrete and/or the 3,300-psi compressive strength is achieved.
  - A copy of the concrete batcher mix slip (concrete mobile) and proof of being a PENNDOT approved supplier shall be provided to the Borough Engineer with each delivery.

#### 6. ADA Detectable Warning Plates

##### PART 1 - GENERAL



- 6.1. Description Of Work
  - 6.1.1. This Work is the installation of detectable warning surface (DWS) plates to be installed in locations as specified in the field and on the drawings.
- 6.2. SUBMITTALS
  - 6.2.1. Certifications: Submit certifications that all DWS plates will meet or exceed designated specifications.
  - 6.2.2. Qualifications of Installer:
    - 6.2.2.1. Installer shall have a minimum of five (5) years of experience with DWS plate installations.
    - 6.2.2.2. Installer shall submit for approval, a list of projects similar in nature and size that establishes his/her ability to complete this project. A resume for the project superintendent should be submitted to establish his/her ability to complete the project. If for any reason, the qualifications are not acceptable, work shall not commence until an acceptable installer is found.

#### PART 2 - PRODUCTS

- 6.3. DWS plates shall be compliant with ADA regulations.
- 6.4. Dimensions and Properties: Detectable Warning Surfaces shall be held within the following dimensions and tolerances:
  - 6.4.1. Length and Width: Minimum 24"x48". Detectable warning surfaces shall extend 24 inches in the direction of travel and shall match the width of the curb ramp (48 inch typical). Standard size plates shall be used. Cutting of plates is not acceptable. Plates can be tiled to achieve required dimensions.
  - 6.4.2. Truncated Domes – DWS shall consist of raised truncated domes with a diameter of nominal 0.9 inch, a height of nominal 0.2 inch and a center-to-center spacing of nominal 2.35 inches.
  - 6.4.3. Slip resistance - ASTM C1028-07 greater than 0.80.
  - 6.4.4. Color Contrast – DWS color shall contrast visually with adjoining surfaces, either light on dark or dark-on-light. Color shall be powder coat red on sidewalk, powder coat yellow on asphalt, or as directed by the ENGINEER.

#### PART 3 - EXECUTION

- 6.5. Installation
  - 6.5.1. Installation shall be performed according to manufacturer's recommendations.
  - 6.5.2. DWS plates shall be installed in a manner that does not create a tripping hazard. Elevation difference between DWS plate and surrounding area shall be less than 0.25 inch.
  - 6.5.3. DWS plates shall be oriented such that truncated domes are both parallel and perpendicular to the direction of pedestrian travel to form a square grid pattern.

- 6.5.4. One corner of the DWS must be within 8 inches from the face of curb. No other point on the leading edge of the DWS may be more than 60 inches from the face of curb. Where no curbs exist the DWS shall be placed respective to edge of roadway.
- 6.5.5. Full thickness sidewalk shall be provided under DWS plates.
- 6.6. Cleaning And Protection
  - 6.6.1. Protect DWS plates against damage during construction period to comply with manufacturer's specification.
  - 6.6.2. Do not allow concrete to cure on DWS plates. Clean excess concrete from DWS plates immediately following installation.
  - 6.6.3. Protect DWS plate surface finish. Do not scratch, chip, or otherwise damage powder coat finish.
- 7. Traffic Signal Supports, Mast Arm & Pedestal
  - 7.1. Traffic signal supports shall be furnished and installed in accordance with Pub. 408/2011.
  - 7.2. Anchor bases (foundations) for the supports shall be one piece in accordance with Pub. 408/2011.
  - 7.3. Traffic signal support poles shall be decorative traffic signal poles and shall have an arm mounting height of 17.5 feet and be manufactured by Union Metal Corporation, National series or approved equivalent. The shaft will extend thirty inches above the center mount of the arm to facilitate the attachment of the incoming electric service or other devices.
  - 7.4. The decorative base should be constructed in gray iron per A.S.T.M. A-48, ductile Iron per A.S.T.M. A536, or aluminum per A.S.T.M. B-26-95 Alloy 356 or approved equivalent resembling in design Union Metal Corporation, National series. The bottom of the base should have a bottom outside diameter minimum of 17", maximum of 30". The top of the base is should be assembled around the smooth tapered steel shaft and shall mate within 1/16" between the inside diameter of the base and the outside diameter of the pole. The overall height of the base shall be less than 40".
  - 7.5. The base casting shall be supplied with a removable access door that is positioned to match the hand hole opening in the steel pole. The access door shall be secured with (2) stainless steel tamper proof machine screws. Each half shall bolt together in such a manner that there remains no greater than 1/32" between the vertical seams.
  - 7.6. The fluted tapered steel pole shall have 16 evenly spaced flutes starting at 40" above the base plate. The base plate shall be 18" square x 1-1/2" thick accepting (4) 1-3/4" x 60" galvanized anchor bolts on an 18" bolt circle. The overall height of the fluted steel shaft shall be 17'-3". A 4" schedule 40 pipe tenon x 34" tall shall be welded to the top of the fluted shaft to accept the casting stack resembling Union Metal Corporation, National series or approved equivalent, and 10" gold ball. The top of the tenon shall have an Y2" x 13" threaded hole in the middle to attach the 10" black anodized aluminum ball.
  - 7.7. The gauge of the fluted steel pole shall be 7 or 3 depending on mast arm lengths and loading criteria. The varying lengths of mast arms shall be attached using a simplex mount and shall be a smooth, tapered curve with a 4' rise. Diameters will vary depending on mast arm lengths and loading criteria.

- 7.8. All poles will be F-283 Galvanized – Powder Top Coat in Black finish and meeting the following requirements:
- Surface Preparation - Prior to being incorporated into an assembled product, steel plated  $\frac{3}{4}$  inches or more in thickness may require blast cleaning to remove rolled-in mill scale, impurities and non-metallic foreign materials. After assembly, all weld flux shall be mechanically removed. The iron or steel product is degreased by immersion in an agitated 4.5%-6% concentrated caustic solution elevated to a temperature ranging from 150F-180F. It is then pickled by immersion in a heated sulfuric acid solution of 13% concentration, controlling the temperature at 150F. It is next rinsed clean from any residual effects of the caustic or acid solutions by immersion in a circulating fresh water bath. Final preparation is done by immersion in a concentrated zinc ammonium chloride flux solution heated to 130F. The solutions acidity content is maintained between 4.5-5.0 pH. The assembly is air dried to remove any moisture remaining in the flux coat and/or trapped within the product.
  - Zinc Coating - The product is hot-dip galvanized to the requirement of either ASTM A123 (fabricated products) or ASTM A 153 (hardware items) by immersion in a molten bath of prime western grade zinc maintained between 810 F-850 F. Maximum aluminum content of the bath is controlled to 0.01%. Flux ash is skimmed from the bath surface prior to immersion and extraction of the product to assure a debris free zinc coating.
  - Top Coat - All galvanized exterior surfaces visually exposed are coated with a Urethane or Triglycdyl Isocyanurate (TGIC) Polyester Powder to a minimum dry film thickness (DFT) of 2.0 mils. Prior to application, the surfaces to be powder-coated are mechanically etched by brush blasting (Ref. SSPC-SP7) and the zinc coated substrate preheated to 450 F for a minimum of one (1) hour in a gas-fired convection oven. The coating is electro-statically applied and cured by elevating the zinc-coated substrate temperature to a minimum of 4000 F in a gas-fired convection oven.
  - Packaging - Prior to shipment small poles shall be wrapped in 0.188" thick ultraviolet-inhibiting, plastic-backed foam. Larger poles shall be cradled in a 1.0" rubberized foam base.
- 7.9. The support poles and mast arms shall be manufactured by Union Metal Corporation, National series or approved equivalent. The support poles shall be installed in accordance with manufacturers' specifications.
- 7.10. Length of supports shall be as shown on the Contract Drawings. The foundation shall be of Class A concrete and the foundation depth for each traffic signal mast arm shall be increased (6) inches beyond the required foundation depth stated in PENNDOT Publication 148, TC-8800 Series.
- 7.11. Pole manufacturer shall verify that the vertical support poles and mast arms are designed to adequately support loads as shown on the contract drawings with maximum load requirements established by AASHTO specifications for structural supports for highway signs, luminaires, and traffic signals, whichever is greater.
- 7.12. The pole shall be grounded to the ground rod and the intersection grounding system, furnishing and installing all needed ground wire. For embedded poles, furnish and install the ground rods and associated hardware.
- 7.13. Following the installation and leveling of the pole and arms, install the base cover or grout pole bases in accordance with Pub. 408/2011.

- 7.14. Traffic signal supports shall be manufactured to easily accommodate additional shaft height for attachment of luminaire extension and arm.
- 7.15. The contractor shall submit shop drawing and PennDOT approval number from the pole manufacturer to the ENGINEER for review and approval prior to ordering poles.
- 7.16. Final location of the traffic signal supports shall be determined in the field by the CONTRACTOR, ENGINEER, Borough officials, and a PennDOT representative.

## 8. Controller Cabinet

- 8.1. The controller unit and each and every piece of the auxiliary equipment shall be housed in a weatherproof cabinet of heavy aluminum sheet construction with a clean-cut design and appearance in accordance with PennDOT Publication 408/2011 specifications. The finish shall be natural with external welds ground flush.
- 8.2. A P-44 base mounted cabinet or approved equal shall be provided as the minimum cabinet size. One cabinet shall be sized accordingly to accommodate a master controller unit and any additional fiber optic panels required for communication should the Borough install a master controller assembly in the future.
- 8.3. The cabinet shall be of adequate size to provide space for the controller and each and every one of the associated electrical devices that are to be furnished or every other accessory herein specified. The cabinet shall contain an adequate number of shelves and brackets to support the controller and each and every one of the other auxiliary equipment.
- 8.4. The cabinet shall be constructed of sheet aluminum. Powder Top Coat in Black Finish with external welds ground flush. Cabinet interior surfaces shall be painted flat white.
- 8.5. A hinged door should be provided permitting complete access to the controller assembly. Door to be hinged on the right side with stops provided at 90 and 180 degrees, + 10 degrees. The door shall provide a device that latches the door when it reaches the extreme open position and holds the door open securely until released. A neoprene gasket to be attached to the door for weather and dust resistance. The door shall be provided with a brass tumbler type lock. Two keys to the main door shall be provided for each cabinet.
- 8.6. The controller cabinet contains an interior light operated by the door for nighttime operation.
- 8.7. A small, hinged, and gasket sealed auxiliary door should be included on the outside of the main cabinet door. The auxiliary door shall not allow access to the controller, its associated equipment, or exposed electrical terminals but shall allow access to a police panel. A neoprene gasket to be attached to the door for weather and dust resistance. The police panel shall be provided with the following switches:
  - Auto/Flash
  - Controller (ON-OFF)
  - Automatic/Manual
- 8.8. A flexible cord with push button should be provided for manual control of the intersection. The auxiliary door shall be provided with a standard police lock. Two keys for the auxiliary door shall be provided with each cabinet.
- 8.9. Electrical connections from the controller (and auxiliary devices) to outgoing and incoming circuits shall be made in such a manner that the controller can be replaced with a similar NEMA compatible unit.

- 8.10. The cabinet shall be furnished with suitable, easily accessible wiring panels. All panel wiring to be neatly arranged and firm. All wiring terminals to be labeled by means of silk-screening.
  - 8.11. The cabinet shall be equipped with an incandescent lamp with flexible shaft for night lighting. A toggle switch to control the lamp to be mounted on the interior of the main door.
  - 8.12. The cabinet shall be equipped with a NEC type, ground fault interrupter duplex receptacle.
  - 8.13. The 15-ampere circuit breaker shown on the PennDOT Standard Drawings for the flasher and GFI receptacle shall also control the fan and the interior lamp.
  - 8.14. The cabinet shall be furnished to accommodate the maximum controller expandability. This shall include cabinet space, connecting cables, wiring terminals and load switch bases to facilitate the operation of the maximum controller expansion.
  - 8.15. The cabinet shall be provided with a detector test panel enabling authorized personnel to place simulated calls to the controller from all pedestrian and vehicular detectors.
  - 8.16. The controller assembly shall include surge protection on the AC service line meeting NEMA TS-2 and PennDOT 408/2011 requirements. This shall be in addition to the standard protection required on the power panel within the controller cabinet. The unit shall be Model SHP-300-10, manufactured by EDCO Incorporated of Florida, or approved equal.
9. Backup Generator Assembly Specifications
- 9.1. A flange inlet receptacle, 30 amp, 120 volts, twist lock, Hubbell Model 2615SW or approved equal shall be provided for the attachment of an alternative power source (emergency generator) on the exterior of the cabinet with a waterproof protective flip top cover.
  - 9.2. The receptacle is to be terminated to an automatic transfer panel to be mounted adjacent to the incoming utility service. The panel is to be assembled using two flash transfer relays isolating the power sources and allowing for immediate return to utility power when available.
  - 9.3. A LED pilot light is to be provided, powered by the emergency generator and operating only to indicate the return of utility power. It will be installed on the cabinet where visible from the roadway.
  - 9.4. Appropriate overload and short circuit protection shall be provided within the controller assembly. A 30 amp circuit breaker should be utilized. The neutral wire of the alternative power source circuit shall be connected with the neutral bus of the controller unit.
10. Controller Assembly
- 10.1. The controller assembly shall be furnished and installed in accordance with the current edition of PennDOT Pub. 408/2011, Section 952 and 953.
  - 10.2. Provide a PEEK Model 3000E Series base mounted, closed loop, 2-8 Phase, Solid State, Actuated, NEMA TS2 - Type II Timer Unit with a NEMA TS2 - Type I back panel assembly, which complies with the most recent NEMA TS2 standards for a Type II Timer Unit and a Type I Assembly. The controller is to provide fully prompted, menu driven programmability. Controller back panel, BIU's, and MMU shall be of the same manufacturer. The controller is to provide fully prompted, menu driven programmability. The controller unit shall be of modular design and utilize a microprocessor for every single one of the timing and control functions.

- 10.3. Programming of controller shall be menu-driven entry through the use of a liquid crystal display, capable of computing force offs and permissives internally. Timing settings shall be accomplished by keyboard entry.
- 10.4. The controller for the flasher assembly shall be equipped with a removable back panel, flasher socket, NEMA 204 Flasher, 20 amp MOV, 15 amp circuit breaker, and 8 position terminal block.
- 10.5. The controller assembly shall meet or exceed the requirements of PENNDOT Publication 408 Sections 952 and 1104 and NEMA Standard TS1 and TS2 for a solid state actuated controller with volume density, NEMA monitor, load-switches and flash relays. Where differences occur, these requirements shall govern. The controller assembly shall provide control for eight phases and shall include the following as standard features:
  - Coordination
  - Time-base control
  - Multiple railroad/fire lane preemption
  - Communications capability
- 10.6. User entered data and intersection configuration programming shall be stored in an electrically erasable programmable read only memory (EEPROM). To facilitate data transfer from one intersection controller to another, the EEPROM device shall be mounted on a sub-module (Data Module).
- 10.7. The controller supplied shall be capable of closed-loop system coordination and emergency pre-emption operation for all phases.
- 10.8. Provide a standard RS-485 Port 1, a standard RS-232C Port 2, and a telemetry interface Port 3 for systems communications as defined by NEMA TS-2 standards.
- 10.9. A solid-state flasher shall be provided in accordance with NEMA standards TS-2, Part 8.
- 10.10. The controller assembly shall contain a NEMA type load bay with proper controller and auxiliary equipment connectors.
- 10.11. Controller assembly shall provide the proper intervals and interval sequence as shown on the contract drawings. Controller shall provide for the setting of each interval, portion of interval, or function by means of a keyboard and Liquid Crystal Display (LCD). Interval and function controls to be located on the front of the controller and shall be properly designated as to the function each control performs. The LCD shall be clearly readable in both bright sunlight and total darkness.
- 10.12. Controller assembly shall be provided with solid-state load switches in accordance with NEMA TS-2 standards. Communication between the Timer Unit and the Load Switches is to be via the Bus Interface Units (BIU's).
- 10.13. Controller assembly shall be equipped with appropriate relays, breakers, receptacles and wire as outlined in PennDOT Publication 408/2011.
- 10.14. Controller assembly to be equipped with a radio frequency interference filter (RFI) in accordance with NEMA standard testing procedures and PennDOT Publication 408/2011.
- 10.15. Controller assembly programming shall be accomplished by the following methods:
  - Front Panel keyboard

- Download from a PC DOS or MS DOS compatible computer (i.e., laptop), running the appropriate software.
  - Download from one intersection controller to another.
  - Data module transfer from one intersection controller to another. (future system capability)
  - Download from a central office by request from an on-street master location. (future system capability)
- 10.16. The controller unit shall be capable of future system interface to an on-street master through telemetry. The controller shall be capable of coordination as instructed by an on-street master or backup modes resident in the intersection controller. The controller shall have the capacity to process data from up to eight system detectors, eight local detectors, and additionally eight expansion detectors (which can be assigned as local or system detectors); the expansion detector feature shall be available on actuated controller. Controller Cabinets will be sized for future Fiber Optic Telemetry equipment.
- 10.17. The controller shall consist of a shelf-mountable enclosure containing electronic modules for processor/display, input/output interface, communications, and power supply functions. In addition, the controller shall be capable of being managed by a master controller at an adjacent intersection.
- 10.18. The Malfunction Management Unit shall meet or exceed all specifications of Section 4 of the NEMA TS2-2003 Standard. It shall provide for 12-16 channels with four (4) inputs per channel meeting NEMA TS-2 standards. Type-12 mode shall provide 12 channels (typically 8 vehicle, 4 overlap), where each channel consists of four 120 VAC inputs (green, yellow, red, Walk). Type-12 mode will provide downward compatibility with a Conflict Monitor Unit (CMU) conforming to TS1. Provide the Borough with a letter of certification from the malfunction management unit manufacturer or an accredited NEMA test laboratory, attesting to the supplied unit operation and compliance with NEMA TS-2 standards. MMU shall be of the same manufacturer as the controller manufacturer.
- 10.19. The operating ambient temperature range for the controller shall be 30° F to 165° F. A 100 cfm (minimum) cooling fan shall be provided. The fan thermostat shall be the line-voltage type, adjustable from 90°F to 150°F, with 10°F turn-off below on position. Weatherproof vents of sufficient area shall be provided in the lower part of the door or cabinet. The vents shall be covered with a disposable filter, held in place with bottom and side brackets.
- 10.20. Controller supplied shall be expandable to a maximum of 8 vehicle phases and 4 pedestrian phases without replacement of the chassis.
- 10.21. Two (2) service manuals containing maintenance information and three (3) total sets of cabinet wiring diagrams shall be furnished with the controller assembly. The controller-wiring diagram shall be specific to the intersection reflecting the wiring of this specific controller. In addition, all signal heads, loop detectors, pedestrian push buttons, and pre-emptive devices must be shown on the wiring diagram.
- 10.22. Prior to submission of catalog cuts, the contractor shall verify that Certificates of Approval, Sale or Provisional, have been issued by the Pennsylvania Department of Transportation for traffic signal equipment, as provided in 67 Pa. Code, Chapter 211. Furnish three copies of warranties, guarantees, and parts lists with the controller catalog cuts.
- 10.23. Upon completion of a controller assembly, a physical and functional shop test shall be conducted of the assembly's continuous, satisfactory operation, for not less than five days. Provide 300W loads for signal circuit and simulated inputs for detectors. Certify that the equipment operates as designed. Prior to the commencement of the bench test, notify the

Borough ENGINEER at least 3 working days in advance so that a representative may inspect the controller assembly at the test site.

- 10.24. Upon completion of the installation, the CONTRACTOR shall notify the ENGINEER. The ENGINEER will notify the Pennsylvania Department of Transportation Engineering District 6-0. The traffic signal shall only be put into operation in the presence of an authorized representative of the PennDOT District ENGINEER.
- 10.25. After the traffic signal installation becomes operational, the CONTRACTOR shall conduct a continuous, 24-hour operating test for not less than thirty consecutive days. Prior to the initiation of stop and go operation the signal operation must be placed in a "flash" mode for a minimum of 5 consecutive calendar days. The initial turn-on shall be in the presence of the PENNDOT Traffic Unit, the ENGINEER and Service Technician from the supplier of the signal controller, between the hours of 9 a.m. and 2 p.m., Tuesday through Thursday, except holidays. Correct failures during this test period by repairing or replacing malfunctioning parts or equipment, or faulty workmanship, regardless of cause, within 24 hours after having been notified by the Borough. In addition, during this time period the Contractor must guarantee the satisfactory in-service operation of mechanical and electrical equipment, related components, signing, pavement markings, and the controller assembly, regardless of the cause for unsatisfactory operation. After correcting failures for any reason, the thirty (30) day testing period will be restarted.
- 10.26. The CONTRACTOR shall be responsible for each and every cost relative to maintaining the traffic signal system throughout the operational test period with the exception of the electricity usage charge.
- 10.27. The entire controller cabinet and all materials within the cabinet shall be warranted free from defects in workmanship and materials for a period of two years from the date of the end of the 30-day test period. This warrantee shall also state that the installation of the emergency generator connection does not void the manufacture warrantee. Any parts found to be defective by the Borough shall be replaced free of charge.
- 10.28. An authorized representative of PennDOT, the OWNER, and the OWNER's Traffic Signal Maintenance Contractor shall perform a final construction observation of the traffic signal installation.
11. Battery Backup/Uninterruptible Power System (UPS)

- 11.1. A Battery Backup/Uninterruptible Power System (UPS) shall be supplied and installed with all new controller assemblies as follows:

11.1.1. Materials:

- LED Signal Battery Backup System NEMA 24-Volt
- 26" high x 44" wide x 26" deep Cabinet height extension skirt. Powder Top Coat in Black Finish with external welds ground flush. Cabinet interior surfaces shall be painted flat white.
- Sealed, Valve Regulated, Lead acid (SVRLA) Outpost batteries
  - a) Number of batteries supplied shall operate the traffic signal in normal operation, not flashing, for a minimum of 8 continuous hours.
  - b) Minimum of 6 batteries shall be supplied.
- All necessary wiring, cables and connections are incidental to this item for complete operation of the system.

11.1.2. Construction:



- Follow manufactures specifications for installation.
- The UPS system battery trays installed in the controller cabinet must be lowered for the batteries to fit under the ledge of the cabinet extension.
- The UPS system shall be tested in the presence of the Borough Engineer and Borough Staff.

## 12. Optical Emergency Vehicle Preemption System

- 12.1. The optical detector shall be a 3M Optical Preemption Detector Model Number 711, 721, 722.
- 12.2. The optical detector shall be a durable, lightweight, overall-weather device that senses optical pulses emitted by properly equipped emergency or transit vehicles in conjunction with the interface card.
- 12.3. The Optical Emergency Vehicle Preemption System shall include detectors, verification/confirmation beacons, preemption card rack, preemption cards, calibration software, and wiring as required for proper operation of the system.
- 12.4. The optical detector shall be designed for easy mounting using standard hardware on either span wire or mast arm. The unit shall have a 1/2" female pipe mount hub and internal terminal block for connection to a 3/C shielded detector cable.
- 12.5. The optical detector shall have a minimum detecting line of sight of 2,500 feet. Where the line sight is obstructed, the detector outputs may be connected in parallel at the controller cabinet to increase the area of coverage.
- 12.6. The optical detector shall operate at 14.035 Hz +/- 0.25 Hz over a temperature range of – 40 degrees C to +75 degrees C.
- 12.7. The optical detector shall have the capability of detecting an optical signal from an emitter provided by either Tomar Electronics, Inc, or 3M Opticom™.
- 12.8. The optical detector must deliver a +24 VDC logic signal to the interface card via optical detector cable at a maximum of 1,000 feet with no splices.
- 12.9. The optical detector shall have physical dimensions of 2.75" diameter (69.8 mm) X 3.375" tall (85.7 mm) with side mounted sight tube. The detector shall weigh 0.85 pounds (0.383 Kg).
- 12.10. The preemption shall be field tested by the contractor in the presence of the Engineer and/or Borough. Following testing, the detector head may need to be relocated and/or adjusted in the field to provide acceptable operation as deemed appropriate by the Engineer, the Borough and PENNDOT.
- 12.11. All components of the pre-emption system shall have full 10-year manufacturer's warranties against defects in material and workmanship.

## 13. Optical Detector Cable

- 13.1. The optical detector cable must guarantee delivery of the necessary quality signal from the optical detector to the interface card over a non-spliced distance of 1,000 feet (305 meters).
- 13.2. The cable must guarantee enough power to the optical detector over a non-spliced distance of 1,000 feet (305 meters).

- 13.3. The cable must be of durable construction to satisfy the following installation methods:
- Direct burial.
  - Conduit and mast arm pull.
  - Exposed overhead (support by messenger wire).
- 13.4. The weight shall not exceed 0.04 lbs./ft. (65.5 grams/meter).
- 13.5. The outside diameter shall not exceed 0.3 inches (7.62mm).
- 13.6. The insulation rating shall be 600 volts minimum.
- 13.7. The temperature rating shall be 80 degrees C minimum.
- 13.8. The cable shall have three conductors of AWG #20 (7x28) stranded, individually tinned copper, color coded insulation as follows:
- Orange for delivery of optical detector power (+).
  - Blue for optical detector power return (-).
  - Yellow for optical detector signal.
- 13.9. The conductors shall be shielded with aluminized polyester and have an AWG #20 (7x28) stranded and individually tinned drain wire to provided signal integrity and transient protection.
- 13.10. The shield wrapping shall have a 20% overlay to warrant integrity following conduit and mast arm pulls.
14. Interface Card
- 14.1. The interface card shall be within a 3M Opticom Card Rack Model 760, or approved equal and shall be installed in the loop amplifier rack model #1881.
- 14.2. The interface card shall have the following Physical dimensions:
- Height 5.80 inch (147.3 mm)
  - Length 8.06 inch (204.7 mm)
  - Width 2.90 inch (73.7 mm)
- 14.3. The interface card shall have the following electrical requirements:
- Voltage 95 to 130 VAC, 50/60 Hz.
  - Current (no detector) 120V input 30.0 Ma.
  - Current (two detectors) 120V input 37.5 Ma.
  - Current (four detectors) 120V input 44.3 Ma.
  - Current (ten detectors) 120V input 66.5 Ma.
- 14.4. The interface card shall operate over an ambient temperature range of -40 degrees C to up to +75 Degrees C.
- 14.5. The interface card shall be able to define additional priority classes within each signal band. Up to 16 priority groups within each signal band may be defined.
- 14.6. The interface card shall handle a maximum of 10 detectors (total for each and every one of the four channels).

- 14.7. The interface card shall be equipped with default priority grouping, responding on a first-come, first-serve basis to signals within each signal band. Signals in the Emergency signal band shall be given priority over signals in the Transit signal band.
  - 14.8. The interface card shall have four detector inputs on one card edge, one for each channel. Each channel may have up to four detectors connected to it in parallel at the detector terminal block.
  - 14.9. The interface card shall have Tri-color LED's and test switches on the front panel to provide output status indication and diagnostic feedback assisting in troubleshooting.
  - 14.10. All input signals must be prediscriminated and validated.
  - 14.11. The interface card shall provide four optically isolated output channels for placing calls on the traffic controllers preempt inputs. All output signals shall comply with NEMA signal level definitions.
  - 14.12. The interface card shall have an output signal format selection field programmable by removing shunt from every channel program block.
  - 14.13. The interface card shall have a disconnect switch mounted on the front panel to allow for setup and testing without placing the intersection into pre-emption mode.
  - 14.14. The physical design of the interface card shall meet each and every NEMA PWB size and construction specifications.
15. Signal Heads
- 15.1. Signal heads shall conform to PennDOT Pub. 408/2011, Section 955, where applicable.
  - 15.2. All new signal heads provided shall be of the same manufacture, and the housings shall be black in color.
  - 15.3. The Traffic Signal Sections shall be rigidly mounted top and bottom. Arm attachment height shall provide for proper clearance of signal heads over the roadway as indicated on the drawings.
  - 15.4. Each signal shall be individually wired with five-conductor or seven-conductor cable as specified in PennDOT Publication 402/2011 and shall be terminated in the pole base. The cable will enter the pole on the underside of the arm through a drilled hole with rubber grommet. Split grommets will not be allowed.
  - 15.5. All signal wiring must terminate on terminal strips. Splices are only permitted in the traffic signal support handhold and shall be in accordance with PENNDOT Section 954.
  - 15.6. All signals shall have a drip loop attached with UV stabilized nylon wire ties.
  - 15.7. All signal brackets shall be attached with  $\frac{3}{4}$ inch stainless steel banding. Use Kelly Bracket as manufactured by Northeast American, AstroBrac as manufactured by Pelco Products, Inc., or approved equal. The brackets will be attached to the pole with stainless steel banding.
  - 15.8. Back plates shall be black, one-piece, UV stabilized, polypropylene or ABS and non-louvered, if requested on the Traffic Signal Permit Plan. All hardware shall be stainless with a permanent black finish. Back plates shall be designed to properly fit the signal manufacturer's heads that will be furnished. A white retro-reflective strip with a minimum

width of 1 inch and a maximum width of 3 inches shall be placed along the perimeter of the face of a signal back plate to project a rectangular appearance at night.

- 15.9. Vehicular signal heads shall be provided with Red, Yellow, and Green L.E.D. indications, including L.E.D. arrows.
- 15.10. Countdown pedestrian signal heads shall be one-piece, symbolic (hand/man) with countdown numerals, L.E.D. Lunar white "walking person", L.E.D. Portland Orange "hand" indications, and L.E.D. Portland Orange countdown numerals, die cast housing with aluminum door as required.

#### 16. Light Emitting Diode Lamp Specifications

- 16.1. All light emitting diode (LED) display units installed within traffic signal head housings should meet the "Equipment and Materials Standards of the Institute of Transportation Engineers (ITE), Vehicle Traffic Control Signal Heads (VTCSH).
- 16.2. Traffic signal display units included under the above ITE specification include red ball, red arrow, pedestrian "hand/man combo" indications in the following standard size configurations:
  - a. 12 inch (300mm) red, yellow and green ball LED signal
  - b. 12 inch (300mm) red, yellow and green left arrow LED signal
  - c. 12 inch (300mm) red, yellow and green right arrow LED signal
  - d. 8 inch (200mm) red, yellow and green ball LED signal
  - e. 16 inch x 18 inch (407mm x 450mm) Portland Orange hand, filled White man one section LED signal
- 16.3. The LED units shall be GELcore, or approved equal.
- 16.4. The LED module must have a Fresnel lens system to provide the look of an incandescent lamp.
- 16.5. The LED units shall consume no more than 10 watts for the red indication, no more than 11 watts for the green indication, and no more than 19 watts for the yellow indication, at a wavelength nominal of 622nm.
- 16.6. The LED units shall operate over a voltage range of 80V – 135V.
- 16.7. The LED units shall operate over a temperature range of –40 degrees C to +74 degrees C.
- 16.8. The LED units shall come with a five-year manufacturer's warranty.

#### 17. Pedestrian Push Buttons

- 17.1. Furnished and installed ADA compliant lighted pedestrian push buttons with latching L.E.D. indications or a vibrotactile ADA compliant Pedestrian Signal (APS) 2" push button with raised directional arrows. The Push Buttons should be equipped with a LED indication that is illuminated upon pedestrian actuation along with a two-tone beep or other audible sounds. The push button shall be installed in accordance with the manufacturer's recommendations. The latching push button control unit and all other required equipment should be installed in accordance with the manufacturer's recommendations.

#### 18. Loop Detectors and Amplifiers

- 18.1. Loop detector installation, if replacing existing loop detectors, shall be in accordance with Pub. 408/2011.
- 18.2. Loop amplifiers, lead-in cable, and sealant shall be in accordance with Pub. 408/2011.
19. Video Detection
  - 19.1. For new detector installations, furnish and install Video Detection system for all approaches, in place of standard in-pavement inductance loop detectors, following the manufactures specification and meeting the following requirements:
  - 19.2. Video Detection system shall include a minimum of one Color Camera for each approach, a detector system, and a rack mounted video detection card.
  - 19.3. This item includes a permanent video monitor (6" minimum) and a mouse located within the controller cabinet for viewing and modifying the programmed detectors.
  - 19.4. This item shall include mounting hardware, wiring, and incidental materials necessary for the operation of the video detection system. The minimum camera mounting height shall be 30 feet above the roadway surface.
  - 19.5. The Video Detection system shall be installed and calibrated in accordance with the manufacturer specifications. PENNDOT, the Borough Engineer must approve the detector layout and operation.
20. Advanced Digital Wave Radar Detection System
  - 20.1. Design, furnish, install, and configure a complete and functioning digital wave radar detection (DWRD) system. This system shall provide for the detection of traffic condition on SR 0029 as indicated, and for the pre-emption mode command signal to the related traffic signal controller. The system shall be robust and shall utilize Commercial Off-The-Shelf (COTS) technologies. The system shall include minimum two digital wave radar zones, related mounting arrangements, cabling, to detect the presence of approaching traffic at the specified detection zones. The detectors, and related support structure, shall be mounted on the indicated signal mast arms or poles.
  - 20.2. The DWRD shall be easy to install; it shall be remotely accessible; it shall provide multiple connectivity options for easy integration into legacy systems; it shall be manufactured to the strictest industry standards; and it shall utilize automated assembly processes to ensure product quality and minimize the risk of failure due to error.
  - 20.3. The DWRD shall have a method for automatically calibrating the detection device; this method will be executed in the DWRD's internal processor. This auto-calibration method shall automatically determine detection thresholds.
  - 20.4. The DWRD shall accurately and continuously detect ETA (Estimated Time of Arrival), speed, and range data for vehicles, or clusters of vehicles simultaneously moving within 100 feet to 500 feet from the sensor in the selected direction of travel. The DWRD shall be mounted in a forward-fire position, looking into either approaching or departing traffic for the selected direction of travel. The DWRD shall filter the ETA data, speed data, and range data based upon minimum and maximum constraints to produce alerts customizable for safe and efficient dilemma zone protection, congestion management, and other operational goals.
  - 20.5. The DWRD shall maintain accurate performance in all weather conditions, including rain, freezing rain, snow, wind, dust, fog and changes in temperature and light. The device shall

not rely on temperature compensation circuitry and shall be capable of continuous operation over an ambient temperature range from -40° C to 75° C, and a relative humidity range from five percent to 95 percent (noncondensing). DWRD operation shall continue in rain or snow up to 10 cm per hour, and the device shall not experience degraded performance when encased in ½" of ice.

- 20.6. Speed data shall be accurate for individual vehicle measurements when there are no adjacent vehicles traveling in the same direction. Eighty-five percent of all measurements shall be within five mph of truth when vehicles are not changing speed. Speed accuracy shall be verified with radar gun, or by video speed trap using the frame rate as a time reference, or equivalent method.
- 20.7. Range data shall be accurate for individual vehicle measurements when there are no adjacent vehicles traveling in the same direction. Eighty-five percent of all measurements shall be within ten feet of the distributed length of the vehicle when vehicles are not changing speed. Range accuracy shall be verified with: LIDAR gun, or by video using visual markers as a distance reference and frame rate as a time reference, or equivalent method.
- 20.8. ETA data shall be accurate for individual vehicle measurements when there are no adjacent vehicles traveling in the same direction. ETA is the estimated time of arrival as calculated by dividing the vehicles range from the stop bar by the speed of the vehicle. ETA is calculated for purposes of safely and efficiently protecting vehicles within the decision dilemma zone, which is nominally defined to exist for motorists with an ETA between 2.5 and 5.5 seconds from the stop bar who are driving faster than 35 mph when the light turns yellow. Eight-five percent of all measurements shall be within one second of truth for all vehicles not changing speed within the decision dilemma zone. ETA accuracy shall be verified with: LIDAR gun, or by video using visual markers as a distance reference and frame rate as a time reference.
- 20.9. To achieve the specified accuracy and reliability, the DWRD shall be installed according to the following conditions:

Two DWRD units shall not be mounted so that they are pointed directly at each other unless separated by more than 700 feet; and a DWRD shall not be placed within 20' of another DWRD unless each device is configured to operate on a different RF channel using the installation software.
- 20.10. The DWRD shall be mounted directly onto a mounting assembly fastened to a pole, overhead mast-arm or other solid structure. The mounting assembly shall provide the necessary degrees of rotation to ensure proper installation. It shall be constructed of weather resistant materials and shall be able to support a 20 lb. load.
- 20.11. The DWRD shall be supplied with a connector cable of the appropriate length for each installation site.
- 20.12. The connector shall meet the MIL-C-26482 specification; the back shell shall be an environmentally sealed shell that offers excellent immersion capability, and is designed to interface with the appropriate MIL-C-26482 connector. All conductors that interface with the connector shall be encased in a single jacket, and the outer diameter of this jacket shall be within the back shell's cable O.D. range to ensure proper sealing; the back shell shall have a strain relief with enough strength to support the cable slack under extreme weather conditions. The MIL-C-26482 connector shall provide contacts for all data and power connection.
- 20.13. The DWRD shall provide two or more communication ports that can be accessed simultaneously using any DWRD-supported protocol. This will enable multiple operators to

collect data from the DWRD at the same time without interrupting or interfering with each other. The DWRD shall provide RS-232 and RS-485 serial communication ports; each communication port shall support all of the following baud rates: 9600, 19200, 38400, 57600 and 115200. Additionally, the RS-232 port shall be full-duplex and shall support true RTS/CTS hardware handshaking for interfacing to various communication devices.

- 20.14. The DWRD shall consume less than 10 watts with a DC input between 12 VDC and 28 VDC. The equipment shall be designed such that the failures of the equipment shall not cause the failure of any other unit of equipment. Automatic recovery from power failure shall be within 15 seconds after resumption of power.
- 20.15. The DWRD shall also include graphical user interface software that displays all configured zones and provides visual representation of all detected vehicle clusters. The detected range, speed, arrival time, and identification number shall be viewable on the visual representation of all detected vehicle clusters. The graphical interface shall operate on Windows 98, Windows 2000, Windows NT 4.0, Windows XP Pro and Windows PocketPCs equivalent to the Dell Axim X50v. The software shall automatically select the correct baud rate.

The graphical user interface shall also display all configured alerts and provide visual representation of their actuation. The operator shall have the ability to configure alerts using minimum and maximum constraints on the detected ETA, speed, and range of vehicles.

The operator shall have the ability to save the configuration information to a file, or reload the DWRD configuration from a file, using the graphical user interface software. Using the installation software, the operator shall be able to easily change the baud rate on the sensor by selecting baud rates from a drop-down list, as well as add response delays for the communication ports. Additionally, the operator shall have the ability to switch between data pushing and data polling, and change the DWRD's settings for Flow Control from none to RTS/CTS and vice versa.

- 20.16. The operator shall be able to upload new firmware into the DWRD's non-volatile memory over any supported communication channel.
- 20.17. All microwave circuitry within the DWRD shall be designed utilizing active control that dynamically adjusts to compensate for temperature and age variations in component performance. This eliminates most opportunities for human error or age degradation in circuits that contribute to product performance. The circuitry shall be void of any manual tuning elements that could lead to human error and degraded performance over time.

All transmit modulated signals shall be generated by means of digital circuitry, such as a direct digital synthesizer, that is referenced to a frequency source that is at least 50 ppm stable over the specified temperature range, and ages less than six ppm per year. Any up-conversion of a digitally generated modulated signal shall preserve the phase stability and frequency stability inherent in the digitally generated signal. These specifications ensure that during operation the DWRD strictly conforms to FCC requirements and that the radar signal quality is maintained for precise algorithmic quality.

The DWRD antennae shall be designed on printed circuit boards, eliminating the need for RF connectors and cabling that result in decreased reliability. Printed circuit antennae are less prone to physical damage due to their extremely low mass.

- 20.18. The DWRD shall be enclosed in a Lexan polycarbonate, ultraviolet resistant material and shall be classified as watertight according to the NEMA 250 Standard. The enclosure shall be classified "f1" outdoor weatherability in accordance with UL 746C.

The DWRD shall be able to withstand a drop of up to 5 feet without compromising its functional and structural integrity.

- 20.19. The DWRD manufacturer shall provide an optional input file card compatible with 170, 2070, NEMA TS1 and NEMA TS2 input file racks. The input file card shall translate per vehicle data packets or real-time true presence packets from the DWRD into corresponding contact closure outputs. Operators shall be able to assign any contact closure output channel to any configured alert. These settings shall be saved in non-volatile memory on the input file card for complete recovery in case of power failure.
- 20.20. The DWRD shall be manufactured and assembled in the U.S.A. The internal electronics of the DWRD shall utilize automation for surface mount and wave solder assembly, and shall comply with the requirements set forth in IPC-A-610C Class 3, Acceptability of Electronic Assemblies.
- 20.21. The DWRD shall undergo a rigorous sequence of operational testing to ensure product functionality and reliability. Testing shall include:
- Functionality testing of all internal subassemblies
  - Unit level burn-in testing of duration 48 hours or greater
  - Final unit functionality testing prior to shipment

Test results and all associated data for the above testing shall be provided, for each purchased DWRD by serial number, upon request. Additionally, manufacturing quality data shall be maintained for each purchased DWRD by serial number and shall also be made available upon request.

Externally, the DWRD shall be modular in design to facilitate easy replacement in the field. The total weight of the DWRD shall not exceed five lbs.

All external parts shall be made of corrosion resistant material, and all materials shall be protected from fungus growth and moisture deterioration.

- 20.22. Each DWRD shall be Federal Communications Commission (FCC) certified under CFR 47, Part 15, section 15.245 as a field disturbance sensor, or section 15.249 as an intentional radiator. This certification shall be displayed on an external label on each device according to the rules set out by the FCC.

The DWRD shall transmit in the 10.50 - 10.55 GHz or 24.00 - 24.25 GHz frequency band and shall meet the power transmission requirements specified under sections 15.245 and 15.249 of CFR 47.

The manufacturer shall provide documentation proving compliance to all FCC specifications.

- 20.23. The DWRD enclosure shall conform to test criteria set forth in the NEMA 250 Standard for Type 4X enclosures. Third party enclosure test results shall be provided for each of the following Type 4X criteria:
- External Icing (NEMA 250 Clause 5.6)
  - Hose-down (NEMA 250 Clause 5.7)
  - 4X Corrosion Protection (NEMA 250 Clause 5.10)
  - Gasket (NEMA 250 Clause 5.14)
  - The DWRD shall comply with the applicable standards stated in the NEMA TS2-1998 Standard



- 20.24. Installers and operators of the DWRD shall be fully trained in the installation, auto configuration and use of the device. The manufacturer shall thoroughly train installers and operators to correctly perform the tasks required to ensure accurate DWRD performance. The amount of training necessary for each project shall be determined by the manufacturer and shall be included, along with training costs, in the manufacturer's quote. In addition, technical support shall be available to provide ongoing operator assistance.
- 20.25. Training shall consist of comprehensive classroom labs and on-hands, in-the-field installation and configuration training.

Classroom Lab training shall involve presentations outlining and defining the DWRD, its functions and the procedures for proper operation. These presentations shall be followed by hands-on labs in which trainees shall practice using the equipment to calibrate and configure a virtual device. To facilitate the classroom presentation and hands-on labs, the vendor shall provide the following items for the duration of training:

- Knowledgeable trainer or trainers thoroughly familiar with the DWRD and its processes.
- Presentation materials, including visual aids, printed manuals and other handout materials for each student.
- Computer files, including video and raw data, to facilitate the virtual calibration and configuration of the DWRD.
- Laptop computers with the necessary software, and all necessary cables, connectors, etc.
- All other equipment necessary to facilitate the virtual calibration and configuration of the DWRD.

Field Training shall provide each trainee with the hands-on opportunity to install and calibrate the DWRD in the field. Training shall be such that each trainee will mount and align the DWRD correctly.

- 20.26. A manufacturer's technical representative shall be available to assist with the physical installation, alignment and auto-calibration of each supplied DWRD. Technical support shall be provided thereafter to assist with troubleshooting, maintenance, or replacement of devices should such services be required.
- 20.27. The following documentation and specification test results shall be supplied by the manufacturer at the time of the bid submittal. Attached documents shall include the following:
- Auto-calibration documentation
  - EN 61000-4-5 Class 4 Lightning Surge Protection test results
  - FCC CFR 47 certification
  - NEMA 250 Standard for Type 4X Enclosure third-party test data
  - NEMA TS2-1998 Standard third-party test data
- 20.28. The DWRD shall be warranted to be free from material and workmanship defects for a period of two (2) years from date of shipment.
- 20.29. Digital Wave Radar Detection System shall be measured as units completely installed, and fully tested, and will include furnishing, installing and installing all materials, including all related support structures, hardware, and fittings, and for all labor, tools, equipment, transportation, and incidentals necessary to complete the work. The lump-sum price shall be disbursed in accordance with the following schedule:

Contractor shall supply approved test plan and procedures within 90 days from NTP. Thirty percent of the lump sum payable after delivery of all equipment for each DWR location of the project. Thirty percent of the lump sum bid price after satisfactory completion of the installation individual sub system at related project site, and approval of all related ON-SITE STAND-ALONE TESTS reports. Twenty percent of the lump sum bid price after satisfactory completion of the system interconnections, installation at project site(s), interconnections and interactions with the traffic signal controllers, and approval of all related SYSTEM ACCEPTANCE TESTS reports. Twenty percent of the lump sum bid price after satisfactory completion of the 180-DAY OPERATIONAL TEST, and the approval of all related test reports.

21. Conduit, Trench & Backfill

- 21.1. Conduit shall be supplied and installed in accordance with Pub. 408/2011, Section 954 and 1100.05(a) and supplemental drawings showing location for the type specified.
- 21.2. Trenching shall be performed to reduce damage to sidewalks, driveways, curb, pavement, and grass areas. Restoration shall be performed to the satisfaction of the BOROUGH ENGINEER and the OWNER. All street crossings should be constructed with a three (3) inch conduit unless superseded by the contract drawings.

22. Junction Boxes

- 22.1. Junction Boxes shall be Type JB-26 or JB-27 as detailed on PennDOT Pub. 148 (TC-8800 Series Drawings), and conforming to Pub. 408/2011, Section 954.
- 22.2. Junction Box adjacent to the controller shall be sized 24"x36."
- 22.3. Junction Boxes shall be located behind existing curbing and/or existing shoulder and shall not be subject to vehicular traffic.
- 22.4. All junction box locations shall be determined in the field prior to construction or in accordance with each and every supplemental drawing showing junction box location and type.
- 22.5. Junction will be labeled "Traffic Signal" for the traffic signal cable.

23. Electrical Distribution

- 23.1. The electrical distribution system shall be furnished and installed by the CONTRACTOR in accordance with Pub. 408/2011, Section 1100.05 and PennDOT Pub. 148, TC-8800 Series.
- 23.2. The electrical service drop shall be Type C and the CONTRACTOR shall coordinate the electrical service drop with the utility company. The electric service shall be housed in an F cabinet or approved equal containing circuit breaker, surge, and lightning arrestor.
- 23.3. The Service cable shall have No. 8 AWG minimum copper conductors. Distribution cable to signal heads shall have No. 14 AWG minimum copper conductors in conformance with International Municipal Signal Association Specification No. 19.1 or 20-1.

24. Pavement Markings

- 24.1. Durable Pavement Marking: Furnished and installed pavement markings as shown on the PENNDOT approved permit plan as specified below:

Thermoplastic pavement markings: All stop bars, crosswalks, legends, and arrows are to be alkylid thermoplastic as specified below:

24.1.1. Materials:

24.1.1.1. White and yellow reflective thermoplastic striping material as provided by an approved manufacturer listed in PENNDOT Bulletin 15 and conforming to AASHTO M 249 (most recent revision)

24.1.1.2. Glass beads – AASHTO M 247, Type I (most recent revision)

24.1.2. Construction:

24.1.2.1. Thermoplastic is to be used for all stop bars, crosswalks, legends, and arrows shown on the approved traffic signal permit plan.

24.1.2.2. The material shall be a minimum of 120mils in thickness.

24.1.2.3. The material shall be applied on dry pavement when the air temperature is between 40° F and 90° F, and when the wind speed is less than 20 MPH. The road surface shall be satisfactorily cleaned and pretreated as required for material adhesion prior to placement of any material. This includes using a binding agent for applications on concrete as required by the manufacturer. A tolerance of one-half inch (1/2") plus or minus from the specified width shall be allowed provided the variation is gradual and does not detract from the general appearance.

24.1.2.4. Preformed pavement markings are required, unless written approval to use molten thermoplastic pavement markings is provided by the ENGINEER or the Borough Public Works Department.

24.1.2.5. After the application of thermoplastic material, protect the markings from traffic for a minimum period of ten (10) minutes or until the thermoplastic has dried sufficiently to prevent dirt pickup or tracking.

24.1.2.6. The contractor will be responsible to maintain all pavement markings installed under this contract for a period of 1 year from the conclusion of the thirty day test. If, during this period, the ENGINEER or PENNDOT determines the pavement markings are in need of replacement, it will be the responsibility of the signal contractor to complete this work at no additional cost to the Borough.

Epoxy Pavement Markings: All long line markings and 24" transverse hatch markings are to be an epoxy resin material as specified below:

24.1.3. Materials:

24.1.3.1. Use only epoxy resins and pigments from an approved manufacturer listed in Bulletin 15.

24.1.3.2. Composition Percentage by Weight

- 24.1.3.3. White Titanium Dioxide 20% + 2 (ASTM D476 Type II) Epoxy Resins 80% + 2
  - 24.1.3.4. Yellow Chrome Yellow 25% + 2(ASTM D211 Type III) Epoxy Resins 75% + 2
  - 24.1.3.5. Dry (cure) to a no track condition in fifteen (15) minutes or less when installed at temperatures above fifty degrees (50°F) at a thickness of fifteen (15) mil and reflectorized with glass beads. 3) Furnish the Borough Traffic Engineer with a copy of the manufacturer specifications for the proper mix ratios of the epoxy component, proper temperatures, proper mixing techniques, and any other necessary data to insure that the epoxy material is being properly installed. 4) Glass Beads AASHTO M 247, Type I (most recent revision)
- 24.1.4. Construction:
- 24.1.4.1. Epoxy resin pavement markings to be used for all long lines and 24" transverse hatch markings shown on the approved traffic signal permit plan.
  - 24.1.4.2. The road surface shall be satisfactorily cleaned and pretreated as required for material adhesion prior to placement of any material. Uniformly apply the epoxy resin markings with a minimum cross section of fifteen (15) mils. A tolerance of one-half inch (1/2") plus or minus from the specified width shall be allowed provided the variation is gradual and does not detract from the general appearance. Conduct epoxy installations only when the road surface temperature is fifty degrees (50°F) or higher. Apply glass beads immediately after application of the epoxy resin at a minimum of twenty five pounds (25 lbs.) per gallon of epoxy. Uniformly distribute glass beads on surface.
  - 24.1.4.3. After the application of epoxy material and glass beads, protect the markings from traffic for a minimum period of thirty (30) minutes or until the epoxy has dried sufficiently to prevent dirt pickup or tracking.
  - 24.1.4.4. The contractor will be responsible to maintain all pavement markings installed under this contract for a period of 1 year from the conclusion of the thirty day test. If, during this period, the Borough Traffic Engineer or PENNDOT determines the pavement markings are in need of replacement, it will be the responsibility of the signal contractor to complete this work at no additional cost to the Borough.
- 24.2. Pavement markings shall be furnished and installed in accordance with the drawings and these specifications, conforming to PennDOT Pub. 408/2011 Section 961 or 962, where applicable.
- 24.3. All longitudinal lines shall be painted for a minimum distance of 150 feet from the stop bars.
- 24.4. Eradicate each and every pavement marking or legend that is in conflict with the pavement markings or legends indicated on the contract drawings, the CONTRACTOR shall eradicate such existing markings or legends by grinding or in such a manner acceptable to

the ENGINEER. Sandblasting will not be an acceptable method of eradication. It is not acceptable to remove markings or legends by painting over them with black paint.

25. Traffic Control Signs

- 25.1. Traffic signs shall be furnished and installed in accordance with the contract drawings and these specifications and shall conform to PennDOT Pub. 212 and 236M.
- 25.2. Post-mounted traffic signs shall be furnished and installed in accordance with Pub. 408/2011 Sections 930, 931, 932, 933, 934, or 935, whichever is applicable, and Pub. 408/2011 Section 1103, where applicable.
- 25.3. Overhead mounted traffic signs shall be furnished and installed in accordance with Pub. 408/2011 Section 936 and PennDOT Pub. 148, TC-8800 Series.
- 25.4. Contractor shall install all mast arm mounted signs with a Kelly Bracket or Astro Bracket, or approved equal with a minimum of two (2) Z-Type brackets on pipes that allow adjustment of the signs. All Street Name Signs shall be installed with a minimum of three (3) "Z-Type" brackets or the use of heavy duty stiffeners with universal channel clamps.
- 25.5. All banding for structure-mounted signs, except for the pedestrian pushbutton signs, shall be ¾ inch stainless steel banding. Pedestrian pushbutton signs may be ½ inch stainless steel banding.
- 25.6. All post-mounted signs shall be installed on breakaway square signposts. Two posts shall be provided for any signs over 48" wide. 4 All sign sheeting must be a minimum ASTM Type III retro reflective.

26. Patterned/Textured Crosswalk

- 26.1. DESCRIPTION – This work is the preparation of the area, supplying and placing a surface dressing, finishing and texture in order to construct decorative crosswalks with the specified color, material, and texture pattern indicated below.
- 26.2. MATERIAL
  - 26.2.1. Where directed, replace material that has not remained within reasonably close conformity to location or has not remained effective in performing useful service for a period of 180 days from the date of acceptance. The service is 90% of material remains in each crosswalk.
  - 26.2.2. AASHTO M 250-05; Impact Resistance 60 ft. lbs, without distress to the area outside the area permanently deformed by the tup.
  - 26.2.3. ASTM D523; Sheen  $\geq 1$  at 85°
  - 26.2.4. ASTM D412; Tensile Strength  $\geq 400$  psi, but can be waved if ASTM D4541 values exceed 400 psi.
  - 26.2.5. ASTM D4060; Abrasion Resistance Maximum loss 100mg/1000 cycles, based on net loss between 500 to 1000 cycles.
  - 26.2.6. ASTM D4541; Adhesion to Asphalt  $\geq 180$  psi
  - 26.2.7. Meet Manufactures Specifications

26.2.8. Furnish a material with a minimum initial skid resistance of 50 British Pendulum Number (BPN) for all crosswalks, stop lines, or where indicated.

26.2.9. Aggregates. ASTM C295-03, Meet manufacturer's specifications

### 26.3. CONSTRUCTION

26.3.1. Weather restrictions.

26.3.1.1. Do not place system when precipitation is expected within 24 hours.

26.3.1.2. Do not place system when air or surface temperature is 10°C (50°F) or lower.

26.3.2. Pattern and Color

26.3.2.1. The color of the pavement surface within the crosswalk shall not degrade the contrast of the white crosswalk lines.

26.3.2.2. Colors shall be limited to silver-gray and be uniform throughout the entire crosswalk area within the crosswalk lines.

26.3.2.3. The following standard highway colors commonly used for traffic control devices shall be avoided:

- red, blue, green, yellow, and orange

26.3.2.4. The ENGINEER will determine whether a proposed color is too close to the colors listed in above.

26.3.2.5. The pattern or texture material within the white crosswalk symbol shall be nonreflective.

26.3.2.6. The textured pattern shall be limited to cobblestone.

26.3.3. Surface Preparation:

26.3.3.1. Place only within the plan designated areas.

26.3.3.2. Apply system to only asphalt or concrete surfaces.

26.3.3.3. Apply system to only asphalt surfaces that show no excessive oxidation. The existing pavement shall be stable, well compacted and in excellent condition.

26.3.3.4. Repair of ruts, raveling, cracks, visible seams, and shallow pints, is required before acceptance of the pavement surface by the installer.

26.3.3.5. Mark out and sawcut the crosswalk edge lines. This sawcut should be made at a depth of approximately 1."

26.3.3.6. Mill all applicable leading edges to a consistent vertical depth ( $\geq$ ) 19mm (3/4 inch) below the existing grade.

26.3.3.7. Clean the surface of all loose particles, dirt, grease, and any other substance that may reduce the systems ability to adhere to the

existing surfaces. Any excessive contaminants like oil or grease are to be removed.

26.3.3.8. Seal concrete surfaces with a material meeting manufacturer's specifications prior to placement of surface treatment.

26.3.3.9. Once complete, the installation area should be cleaned thoroughly with compressed air and a Hot Compressed Air (HCA) Lance, if necessary.

#### 26.3.4. Material & Tool Preparation

26.3.4.1. If necessary, material should be heated in a diesel-fired, air-jacketed horizontally mounted kettle with a minimum capacity of 4,000lbs. Pre-heat kettle to approximately 250°F and begin adding bags of material in 5-10 bag increments until full. When adding material to the kettle, add one packet of color per bag of material. Heat material to approximately 400°F. Be sure to maintain constant agitation and avoid overheating the material.

26.3.4.2. If necessary, heat the smoothing irons in a propane flame until red-hot.

#### 26.3.5. Placement through One of the Following Two Methods:

##### Method 1

26.3.5.1. Mixture proportions are proprietary but must account for color and traffic use.

26.3.5.2. Thoroughly mix part 'A' (Resin) with part 'B' (Hardener) utilizing a suitable heavy duty electric paddle mixer or similar in amounts recommended by manufacturer.

26.3.5.3. Pre-wash and completely dry all aggregates and provide bagged materials consistent with the mixture proportions before batching and mixing.

26.3.5.4. Thoroughly mix aggregates and polyurethane binder mixture in the amounts recommended by manufacturer.

26.3.5.5. Apply, uniformly spread and finish surface between the grade control forms utilizing rubber squeegees and trowels as recommended by the manufacturer and as shown on the plans.

26.3.5.6. Imprint using an approved mold capable of providing a 9mm to 13mm (3/8 inch to 1/2 inch) deep imprint with the design details shown on the plans.

26.3.5.7. Use a manufacturer approved release agent to prevent imprinted material from sticking to the mold.

26.3.5.8. Provide a final texture and pattern shown on the plans.

26.3.5.9. Border the decorative crosswalk by installing two white parallel lines (minimum 6 inches wide) with a PennDOT approved pavement

marking material that extends from face of curb to face of curb or edge of shoulder.

- 26.3.5.10. Remove all loose sand and clean entire surface area after Imprinting.
- 26.3.5.11. Do not allow vehicular traffic or loads on the system for a minimum of two hours from applications or until the mixture is tack free.

#### Method 2

- 26.3.5.12. Discharge the material into buckets treated with a suitable release agent and apply it in the desired area. Using the hot smoothing irons, spread the material to the desired thickness and tool it to a smooth bubble-free surface. If required, battens can be applied to the surrounding wearing course to aid in the determination of thickness. Once the desired surface texture has been achieved, apply a thin layer of dry silica sand to the surface.
- 26.3.5.13. If joining new material to some already in place, be sure to heat the existing material to a temperature of approximately 300°F with a propane torch before ironing the new material into place to ensure a tight bond and prevent joint shrinkage.
- 26.3.5.14. Once the sand has been applied, begin imprinting the material with the appropriate mold. Press the mold into the material to a depth of .2”-.5” unless otherwise requested. Imprint in such a manner that the pattern is straight from beginning to end. Avoid excessive material displacement while imprinting. Periodically inspect the mold and remove any adhered material. Complete the pattern along the edge lines using detail tools. These tools may be heated if necessary.
- 26.3.5.15. If the pattern needs to be corrected, it can sometimes be reheated and smoothed with the irons before being reprinted. In extreme cases, the material will have to be removed and reapplied.

#### 26.3.6. Submittals/Qualifications

- 26.3.6.1. The installer will provide technical specifications, MSDS sheets and color and pattern samples as needed. Typical color samples will be mounted and delivered to the Project Owner.
- 26.3.6.2. Installer Qualifications – Installer must have at least 3 years of successful installation experience and be able to provide references for projects similar in size and scope.