

BILL NO. 3519

ORDINANCE NO. 3308

AN ORDINANCE VACATING A PORTION OF RIGHT-OF-WAY ON LONG ROAD CROSSING DRIVE WITHIN THE LONG ROAD CROSSING SUBDIVISION PLAT RECORDED IN BOOK 352, PAGE 232 OF THE ST. LOUIS COUNTY, MISSOURI RECORDS, LOCATED IN U.S. SURVEY 1010, TOWNSHIP 45 NORTH, RANGE 3 & 4 EAST OF THE FIFTH PRINCIPAL MERIDIAN, CITY OF CHESTERFIELD, ST. LOUIS COUNTY, MISSOURI.

WHEREAS, a petition has been filed by Kehr Development, LLC, requesting the City to vacate right-of-way on Long Road Crossing Drive; and,

WHEREAS, Kehr Development, LLC, owns the properties on which the easement is located and has no need for the easement; and,

WHEREAS, the Departments of Planning and Public Works have reviewed the petition and have determined that said petition meets all applicable regulations and that the vacation will have no adverse effect on the City of Chesterfield.

NOW THEREFORE BE IT ORDAINED BY THE CITY COUNCIL OF THE CITY OF CHESTERFIELD, ST. LOUIS COUNTY, MISSOURI, AS FOLLOWS:

Section 1. The City Council of the City of Chesterfield hereby approves the right-of-way vacation located on Long Road Crossing Drive of Long Road Crossing Subdivision Plat Book 352, page 232 of the St. Louis County, Missouri records, as described in Exhibit 3, which is attached hereto and made part of hereof; and

Section 2. The Mayor and City Clerk are authorized and directed to evidence the approval of the vacation of right-of-way easement by affixing their signatures and the Official Seal of the City of Chesterfield to a Certificate of Approval as required on said documents. The petitioner is required and directed to record this easement vacation with the Saint Louis County Recorder of Deeds Office; and

Section 3. The Ordinance shall be in full force and effect from and after its passage and approval.

Passed and approved this 3rd day of September, 2024.

Bob Nation
PRESIDING OFFICER

Bob Nation
Bob Nation, MAYOR

ATTEST:

Vickie McGownd
Vickie McGownd, CITY CLERK

NOTICE OF VACATION OF EASEMENT

NOTICE IS HEREBY GIVEN that the City of Chesterfield has received a petition to vacate the 1,437 square feet of right-of-way easement situated in the City of Chesterfield, Missouri. Should anyone have an interest in this, please contact Shilpi Bharti, Planner at 636-537-4743 or email at Sbharti@chesterfield.mo.us. The legal description of the property to be vacated is as follows:

A portion of Long Road Crossing Drive, as established by PB. 352, PG. 232, located in U.S. Survey 1010, Township 45 North, Ranges 3&4 east of the fifth principal meridian, City of Chesterfield, St. Louis County, Missouri.

GRAPHIC SCALE

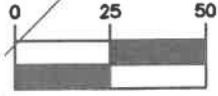

(IN FEET)
1 inch = 50 ft.



N/F
KEHR DEVELOPMENT LLC
LOC. #17U410214,
714 LONG ROAD CROSSING DR
DB. 11522, PG. 589

N/F
KEHR DEVELOPMENT LLC
LOC. #17U10094,
97 LONG ROAD
DB. 11522, PG. 589
LOT C
PB. 354, PG. 186

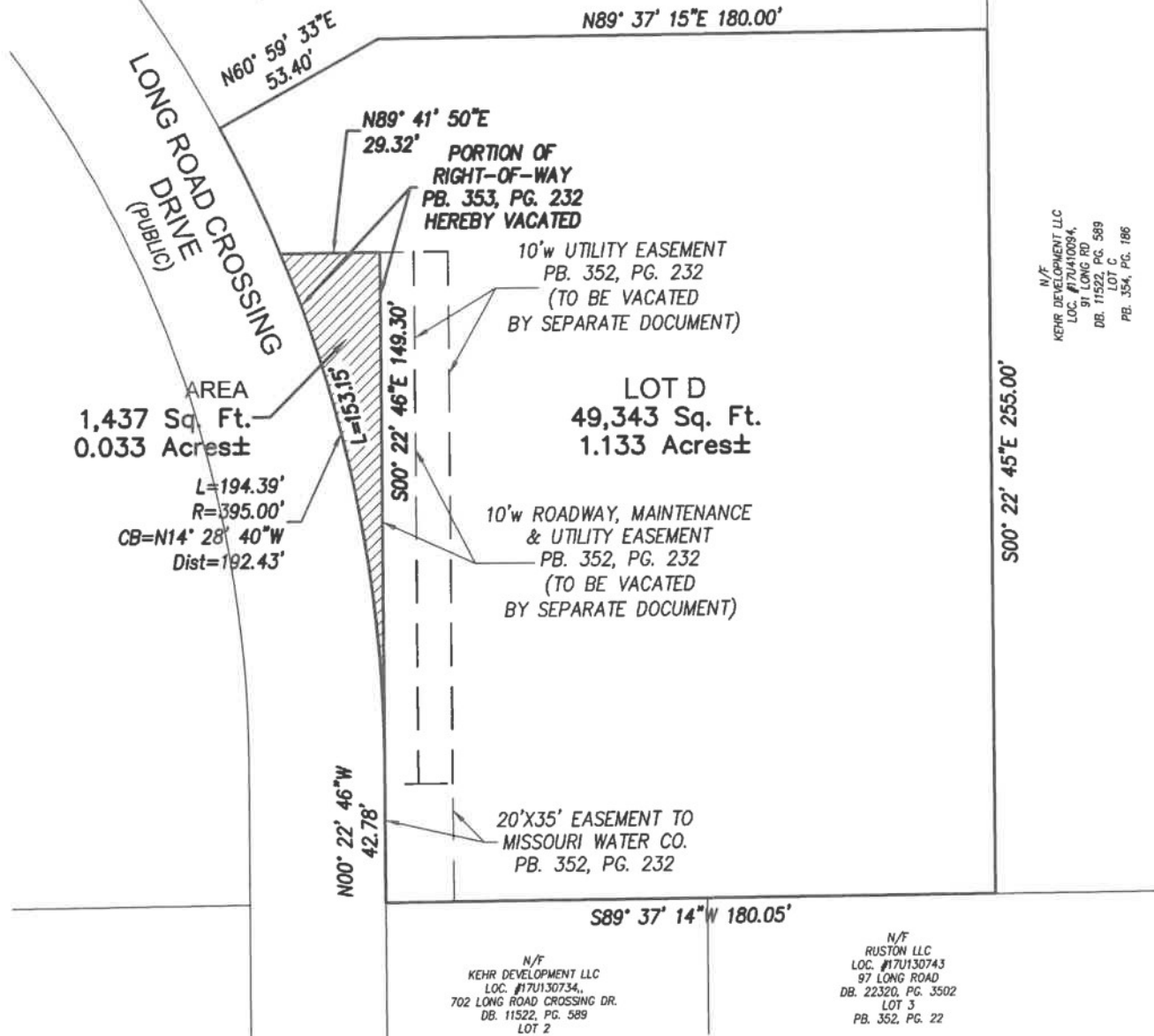

N/F
KEHR DEVELOPMENT LLC
LOC. #17U130734,
702 LONG ROAD CROSSING DR.
DB. 11522, PG. 589
LOT 2

N/F
RUSTON LLC
LOC. #17U130743
97 LONG ROAD
DB. 22320, PG. 3502
LOT 3
PB. 352, PG. 22

EXHIBIT

RIGHT-OF-WAY VACATION EXHIBIT

A PORTION OF LONG ROAD CROSSING DRIVE, AS ESTABLISHED BY PB. 352, PG. 232, LOCATED IN U.S. SURVEY 1010, TOWNSHIP 45 NORTH, RANGES 3 & 4 EAST OF THE FIFTH PRINCIPAL MERIDIAN, CITY OF CHESTERFIELD, ST. LOUIS COUNTY, MISSOURI

2024080500253

CERTIFIED-FILED FOR RECORD
8/5/2024 11:14:32AM

Gerald Smith
Recorder of Deeds
COUNTY OF ST. LOUIS, MISSOURI

PAGES: 6
RECORDING FEE: \$36.00

THIS DOCUMENT WAS ERECORDED

Gerald Smith, Recorder of Deeds
ST. LOUIS COUNTY MISSOURI
41 S Central Ave, Clayton, MO 63105

Type of Instrument: VACATION
Grantor: METROPOLITAN ST LOUIS SEWER DISTRICT
Grantee: KEHR DEVELOPMENT LLC

NOTE: I, the undersigned Recorder of Deeds, do hereby certify that the information shown on this Certification Sheet as to the **TYPE OF INSTRUMENT, the NAMES of the GRANTOR and GRANTEE as well as the DESCRIPTION of the REAL PROPERTY affected** is furnished merely as a convenience only, and in the case of any discrepancy of such information between this Certification Sheet and the attached Document, **the ATTACHED DOCUMENT governs**. Only the DOCUMENT NUMBER, the DATE and TIME of filing for record of the recorded Document is taken from this CERTIFICATION SHEET.

RECORDER OF DEEDS DOCUMENT CERTIFICATION

STATE OF MISSOURI)
 SS.
COUNTY OF ST. LOUIS)

I, the undersigned Recorder of Deeds for said County and State, do hereby certify that the following and annexed instrument of writing, which consists of 6 pages, (this page inclusive), was filed for record in my office on the 5 day of August 2024 at 11:14 am and is truly recorded as the document number printed above.

In witness whereof I have hereunto set my hand and official seal the day, month and year aforesaid.

DWS
Deputy Recorder



Gerald E. Smith

Recorder of Deeds
St. Louis County, Missouri

3 INCH AREA ABOVE - LEAVE BLANK (FOR RECORDERS OFFICE USE ONLY)

DOCUMENT TYPE: EASEMENT VACATION

DATE OF DOCUMENT: 8/5/2024

GRANTOR: METROPOLITAN ST. LOUIS SEWER DISTRICT
2350 MARKET STREET
ST. LOUIS, MISSOURI 63103

GRANTEE: KEHR DEVELOPMENT LLC
911 S. 13TH ST.
ST. LOUIS MO 63005

PROPERTY ADDRESS: 706 LONG ROAD
CHESTERFIELD MO 63005

LOCATOR #: 17U410104

CITY/MUNICIPALITY: CHESTERFIELD, MISSOURI

LEGAL DESCRIPTION: PORTION OF ROADWAY, MAINTENANCE, & UTILITY
EASEMENT, AS ESTABLISHED BY PB. 352, PG. 232,
LOCATED IN U.S. SURVEY 1010, TOWNSHIP 45 NORTH,
RANGES 3 & 4 EAST OF THE FIFTH PRINCIPAL MERIDIAN,
CITY OF CHESTERFIELD, ST. LOUIS COUNTY, MISSOURI

E A S E M E N T V A C A T I O N

TO WHOM IT MAY CONCERN

KNOW ALL MEN BY THESE PRESENTS, that Metropolitan St Louis Sewer District (MSD) does hereby vacate any right, title, or interest to the portions of the easements as recorded in Plat Book 352 Page 232 of the St Louis County Recorder's Office and shown hachured on the attached "Easement Vacation Exhibit" and marked "Exhibits "A", "B", and "C" and made a part hereof. The owners of the subject property have requested MSD to vacate the portions of the subject easements, and this District has no further use for said portions of easements as shown on the attached plat

IN WITNESS WHEREOF, the said Metropolitan St Louis Sewer District has caused these presents to be signed by its Director of Engineering this 5 day of August, 2024

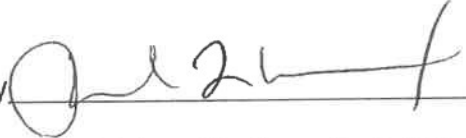
Metropolitan St Louis Sewer District
By 
Richard L. Unverferth PE
Director of Engineering

STATE OF MISSOURI)
) SS
COUNTY OF ST LOUIS)

On this 5 day of August, 2024, before me appeared Richard L. Unverferth, to me personally known, who being by me duly sworn, did say he is Director of Engineering of The Metropolitan St Louis Sewer District and that said instrument was signed on behalf of said corporation by authority of its Board of Trustees, and said Richard L. Unverferth acknowledged said instrument to be the free act and deed of said corporation

IN TESTIMONY WHEREOF, I have herewith set my hand and affixed my notarial seal the day and year first above written
My Commission expires 10/30/27

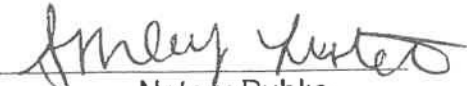
Notary Public

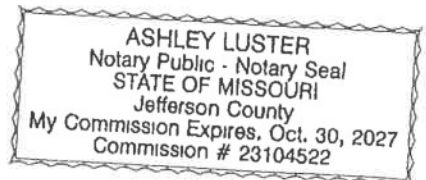

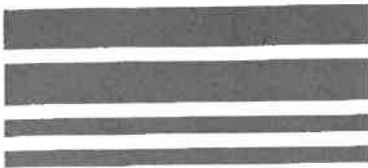

* 2006012500760 *

JANICE M. HAMMONDS, RECORDER OF DEEDS
ST. LOUIS COUNTY MISSOURI
41 SOUTH CENTRAL, CLAYTON, MO 63105

TYPE OF INSTRUMENT
VACA

GRANTOR TO
CHARTER COMMUNICATIONS ENT I L
L C

GRANTEE
COUNTY OF ST LOUIS

PROPERTY DESCRIPTION:

LONG CROSSING LOT 4 PB 352 PG 232

Lien Number

Notation

Locator

NOTE: I, the undersigned Recorder of Deeds, do hereby certify that the information shown on this Certification Sheet as to the TYPE OF INSTRUMENT, the NAMES of the GRANTOR and GRANTEE as well as the DESCRIPTION of the REAL PROPERTY affected is furnished merely as a convenience only, and in the case of any discrepancy of such information between this Certification Sheet and the attached Document, the ATTACHED DOCUMENT governs. Only the DOCUMENT NUMBER, the DATE and TIME of filing for record, and the BOOK and PAGE of the recorded Document is taken from this CERTIFICATION SHEET.

RECORDER OF DEEDS DOCUMENT CERTIFICATION

STATE OF MISSOURI)
SS.
COUNTY OF ST. LOUIS)

Document Number
760

I, the undersigned Recorder of Deeds for said County and State, do hereby certify that the following and annexed instrument of writing, which consists of 4 pages, (this page inclusive), was filed for record in my office on the 25 day of January 2006 at 02:11 PM and is truly recorded in the book and at the page shown at the top and/or bottom of this page.

In witness whereof I have hereunto set my hand and official seal the day, month and year aforesaid.

Jolann Reber
Deputy Recorder

Janice M. Hammonds
Recorder of Deeds
St. Louis County, Missouri



RECORDING FEE \$30.39
(Paid at the time of Recording)

- N.P
- N.P.C
- N.N.C.
- N.N.I.

Mail to:

attn:
Stack Associates Research
257 Chesterfield Business Plaza
Chesterfield, MO 63005

Destination code: M

B-17037 P-2505/2508

3

VACATION OF EASEMENT

This instrument is made as of this 19th day of January, 2006.

WITNESSETH that:

WHEREAS, an easement for broadband cable communications placement within the dedicated right-of-way and utility easement has been granted to Charter Communications Entertainment I, LLC ("Charter") by St. Louis County, Missouri within a tract of land being part of Lot 4 of Long Crossing Lots 2, 3, and 4, which tract of land is recorded Plat Book 352, Page 232 in the records of the St. Louis County Recorder of Deeds Office; and

WHEREAS, it is the purpose and intent of Charter to release a portion of such easement rights within the "hatched" area of the above-described easement shown in Exhibit A, attached hereto and incorporated herein by this reference.

NOW THEREFORE, Charter does hereby relinquish and release that portion of its easement rights to place or maintain permanent facilities within the "hatched" area of the easement shown in Exhibit A. Except for the release of that hatched area described herein, the remaining easement rights and interests granted to Charter pursuant to the aforementioned plat shall remain in full force and effect.

IN WITNESS THEREOF, Charter has caused this document to be executed as of the date first written above.

Charter Communications Entertainment I, LLC

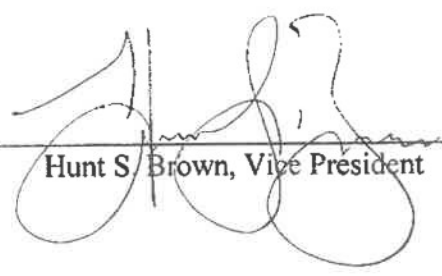
By: 
Hunt S. Brown, Vice President

STATE OF MISSOURI)
) ss.
COUNTY OF ST. LOUIS)

On this 19th day of January, 2006, before me appeared Hunt S. Brown, who being by me duly sworn, did say that he is a Vice President of Charter Communications Entertainment I, LLC, a limited liability company duly organized and existing under the laws of the State of Delaware, that this instrument was signed on behalf of said company by authority of its board of directors, and that Hunt S. Brown declared that his signature placed hereon was the free act and deed of said company.

IN TESTIMONY WHEREOF, I have hereunto set my hand on the day and year and in the County and State last written above.

Notary Public

My Commission Expires:

6/17/08

KATHERINE G. KNAPP
Notary Public — Notary Seal
STATE OF MISSOURI
St. Louis County
My Commission Expires: June 17, 2008

DATE: 12/21/05

JOB NO. 203-3147.5

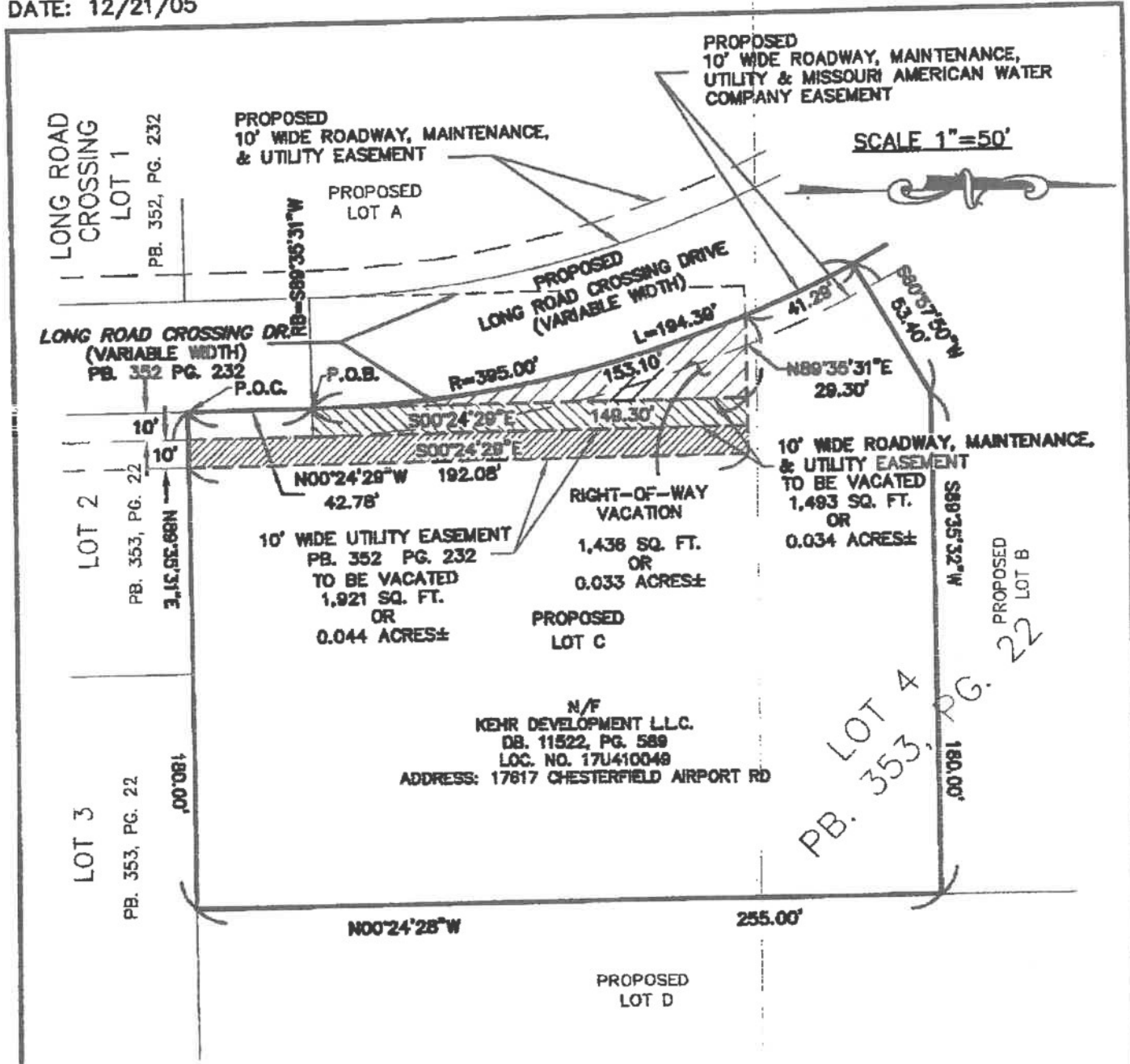
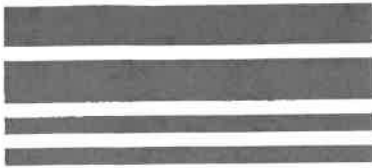

EXHIBIT 'A'

INITIAL:

RIGHT-OF-WAY VACATION PLAT

A TRACT OF LAND BEING PART OF LOT 4 OF LONG ROAD CROSSING LOTS 2, 3, AND 4,
 A RESUBDIVISION OF LONG ROAD CROSSING AS RECORDED IN PLAT BOOK 353, PAGE 22
 LOCATED IN U.S. SURVEY 1010, TOWNSHIP 45 NORTH, RANGE 3 AND 4 EAST
 OF THE 5TH PRINCIPAL MERIDIAN,
 CITY OF CHESTERFIELD, ST. LOUIS COUNTY, MISSOURI



* 2 0 0 6 0 1 2 7 0 0 9 4 3 *

**JANICE M. HAMMONDS, RECORDER OF DEEDS
ST. LOUIS COUNTY MISSOURI
41 SOUTH CENTRAL, CLAYTON, MO 63105**

TYPE OF INSTRUMENT: **REL**
GRANTOR: **LACLEDE GAS CO**
TO:
GRANTEE: **KEHR DEVELOPMENT L L C**

PROPERTY DESCRIPTION: **SUR 1010 T 45 R 3E**

Lien Number: [] Notation: [] Locator: []

NOTE: I, the undersigned Recorder of Deeds, do hereby certify that the information shown on this Certification Sheet as to the TYPE OF INSTRUMENT, the NAMES of the GRANTOR and GRANTEE as well as the DESCRIPTION of the REAL PROPERTY affected is furnished merely as a convenience only, and in the case of any discrepancy of such information between this Certification Sheet and the attached Document, the ATTACHED DOCUMENT governs. Only the DOCUMENT NUMBER, the DATE and TIME of filing for record, and the BOOK and PAGE of the recorded Document is taken from this CERTIFICATION SHEET.

RECORDER OF DEEDS DOCUMENT CERTIFICATION

STATE OF MISSOURI)
SS.
COUNTY OF ST. LOUIS)

Document Number
943

I, the undersigned Recorder of Deeds for said County and State, do hereby certify that the following and annexed instrument of writing, which consists of 4 pages, (this page inclusive), was filed for record in my office on the 27 day of January 2006 at 03:50 PM and is truly recorded in the book and at the page shown at the top and/or bottom of this page.

In witness whereof I have hereunto set my hand and official seal the day, month and year aforesaid.

Jolynn Reber
Deputy Recorder

- ___ N.P
- ___ N.P.C
- ___ N.N.C.
- ___ N.N.I.



Janice M. Hammonds
Recorder of Deeds
St. Louis County, Missouri

RECORDING FEE \$30.39
(Paid at the time of Recording)

Mail to: *Stock & Associates* atn: *Research*
257 Chesterfield Business Pkwy
Chesterfield, Mo 63005

Destination code: **M**

B-17042 P-2263/2266

3

PARTIAL RELEASE OF EASEMENT

THIS INSTRUMENT, made this 12th day of January, 2006,
WITNESSETH THAT:

WHEREAS, there has heretofore been granted to Laclede Gas Company, a Missouri corporation, ("GRANTOR"), an easement ("Easement") in certain land located within U. S. Survey 1010, Township 45 North, Range 3 and 4 East, which easement is recorded in Plat Book 352, page 232, of the St. Louis County, Missouri Records wherein the nature and extent of the Easement and the lands affected are described; and

WHEREAS the present owner, Kehr Development L.L.C. ("GRANTEE") of the lands so affected, have requested that GRANTOR release part of the Easement and GRANTOR is willing to do so to the extent hereinafter described.

NOW THEREFORE, in consideration of One Dollar (\$1.00) in hand paid to GRANTOR by said GRANTEE, the receipt of which is hereby acknowledged, GRANTOR hereby RELEASES AND QUITCLAIMS to said GRANTEE all of GRANTOR'S right, title and interest in and to that part of the Easement as shown hatched on the attached plat designated Exhibit A.

IN WITNESS WHEREOF, GRANTOR has caused this instrument to be signed by its Vice President, Operations and its corporate seal hereunto affixed the day and year first above written.

LACLEDE GAS COMPANY

By Craig R. Hoeflerlin
Craig R. Hoeflerlin
Vice President, Operations



M. C. Kullman
M. C. Kullman - Secretary

STATE OF MISSOURI)
) ss.
CITY OF ST. LOUIS)

On the 12 day of JANUARY, 2006, before me,
TOD J. FAGAN, a notary public in and for said state,
appeared Craig R. Hoferlin, to me personally known, who being by me duly sworn, did say that he is
Vice President, Operations of Laclede Gas Company and that said instrument was signed and sealed in
behalf of said corporation by authority of its Board of Directors and said Craig R. Hoferlin
acknowledged said instrument to be the free act and deed of said corporation.

My Commission expires: 2-27-2006

Tod J. Fagan
Notary Public



DATE: 12/21/05

PROPOSED JOB NO. 203-3147.5
10' WIDE ROADWAY, MAINTENANCE,
UTILITY & MISSOURI AMERICAN WATER
COMPANY EASEMENT

SCALE 1"=50'

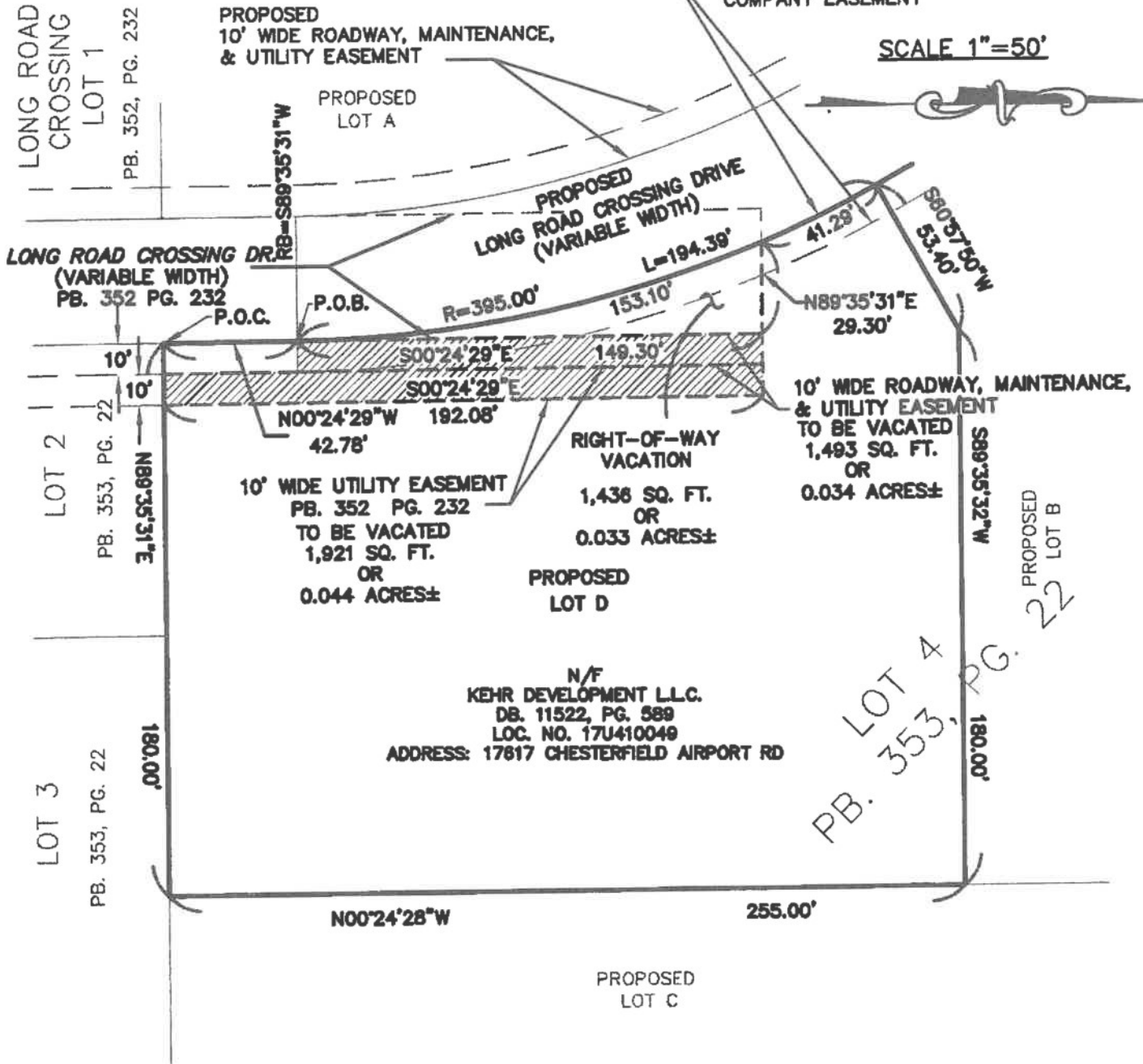

EXHIBIT "A"

INITIAL:

EASEMENT VACATION PLAT

A TRACT OF LAND BEING PART OF LOT 4 OF LONG ROAD CROSSING LOTS 2, 3, AND 4,
 A RESUBDIVISION OF LONG ROAD CROSSING AS RECORDED IN PLAT BOOK 353, PAGE 22
 LOCATED IN U.S. SURVEY 1010, TOWNSHIP 45 NORTH, RANGE 3 AND 4 EAST
 OF THE 5TH PRINCIPAL MERIDIAN,
 CITY OF CHESTERFIELD, ST. LOUIS COUNTY, MISSOURI

F:/DRAW3100/2033147/SURVEY/LOT-4_VAC_EXH.DWG

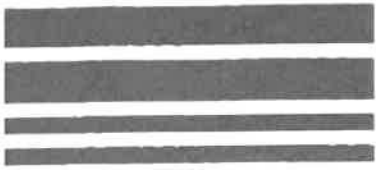

* 2 0 0 6 0 2 2 2 0 0 7 3 8 *

JANICE M. HAMMONDS, RECORDER OF DEEDS
ST. LOUIS COUNTY MISSOURI
41 SOUTH CENTRAL, CLAYTON, MO 63105

TYPE OF INSTRUMENT
REL

GRANTOR
S B C MISSOURI

TO

GRANTEE
KEHR DEVELOPMENT L L C

PROPERTY DESCRIPTION:

LONG ROAD CROSSING RESUB LOT PT 4 PB 353 PG 22

Lien Number

Notation

Locator

NOTE: I, the undersigned Recorder of Deeds, do hereby certify that the information shown on this Certification Sheet as to the TYPE OF INSTRUMENT, the NAMES of the GRANTOR and GRANTEE as well as the DESCRIPTION of the REAL PROPERTY affected is furnished merely as a convenience only, and in the case of any discrepancy of such information between this Certification Sheet and the attached Document, the ATTACHED DOCUMENT governs. Only the DOCUMENT NUMBER, the DATE and TIME of filing for record, and the BOOK and PAGE of the recorded Document is taken from this CERTIFICATION SHEET.

RECORDER OF DEEDS DOCUMENT CERTIFICATION

STATE OF MISSOURI)
SS.
COUNTY OF ST. LOUIS)

Document Number
738

I, the undersigned Recorder of Deeds for said County and State, do hereby certify that the following and annexed instrument of writing, which consists of 3 pages, (this page inclusive), was filed for record in my office on the 22 day of February 2006 at 10:54 AM and is truly recorded in the book and at the page number printed above.

In witness whereof I have hereunto set my hand and official seal the day, month and year aforesaid.

J. Ann Reber
Deputy Recorder



Janice M. Hammonds
Recorder of Deeds
St. Louis County, Missouri

Mail to:
attn:
Stock & Associates Research
257 Chesterfield Business Pkwy
Chesterfield, Mo 63005

Destination code: M

- ___ N.P.
- ___ N.P.C.
- ___ N.N.C.
- ___ N.N.I.

RECORDING FEE \$27.39
(Paid at the time of Recording)

2



Missouri

Release of Easement

THIS RELEASE OF EASEMENT, entered into by **SOUTHWESTERN BELL TELEPHONE, LP, dba, SBC Missouri** (f/k/a Southwestern Bell Telephone Company) 12930 Olive Blvd., Creve Coeur, Missouri 63141, GRANTOR, Present Owners **KEHR DEVELOPMENT LLC 17617 CHESTERFIELD AIRPORT RD CHESTERFIELD MO**, GRANTEES, wherein GRANTOR, in consideration of One Dollar (\$1.00) and other valuable consideration, receipt of which is hereby acknowledged, does by these presents ABANDON, RELEASE, RELINQUISH AND DISCLAIM to GRANTEES, all or a specific portion of a certain easement for telephone Communications Purposes hereinafter described that affects land owned by GRANTEES situated in **St. Louis County, State of Missouri**, and described as follows:

A TRACT OF LAND BEING PART OF LOT 4 OF LONG ROAD CROSSING LOTS 2, 3, AND 4, A RESUBDIVISION OF LONG ROAD CROSSING AS RECORDED IN PLAT BOOK 353, PAGE 22 LOCATED IN U.S. SURVEY 1010, TOWNSHIP 45 NORTH, RANGE 3 AND 4 EAST OF THE 5th PRINCIPAL MERIDIAN, CITY OF CHESTERFIELD COUNTY OF ST. LOUIS STATE OF MISSOURI.

Said Land of GRANTEES being subject to: **Easement recorded in favor of SBC Missouri.**

The portion of said easement to be hereby released is described as follows: **A dedicated 10' wide easements and right of way indicated as the area shown as hachured upon "EXHIBIT "A" attached hereto and made a part thereof.**

TO HAVE AND TO HOLD same, together with all rights and appurtenances to the same belonging, unto GRANTEES, their heirs, successors and assigns forever.

IN WITNESS WHEREOF, GRANTOR has caused this Release of Easement to be executed by its duly authorized officers this day ~~11th~~ ^{16th} of ~~January~~ ^{February}, 2006

SBC Missouri

Melvon L. Houston
Director-Engineering/Construction (Missouri)

STATE of Missouri
COUNTY of St. Louis

BEFORE ME, the undersigned authority, on this day personally appeared Melvon L. Houston, known to me to be the person whose name is subscribed to the foregoing instrument, and upon being duly sworn did state and acknowledge that he is the Director-Engineering/Construction (Missouri) of SBC Missouri, a Limited Partnership organized under the laws of the State of Texas, and that he executed the foregoing instrument in the capacity stated under authority of its Board of Directors purposes and considerations therein expressed as the free and voluntary act and deed of SBC Missouri.

Given under my hand and seal of office this the ~~11th~~ ^{16th} day of ~~January~~ ^{February} 2006 AD

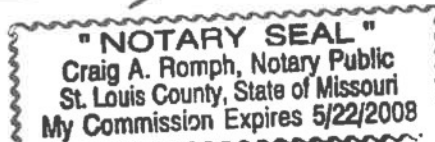

DATE: 12/21/05

JOB NO. 203-3147.5

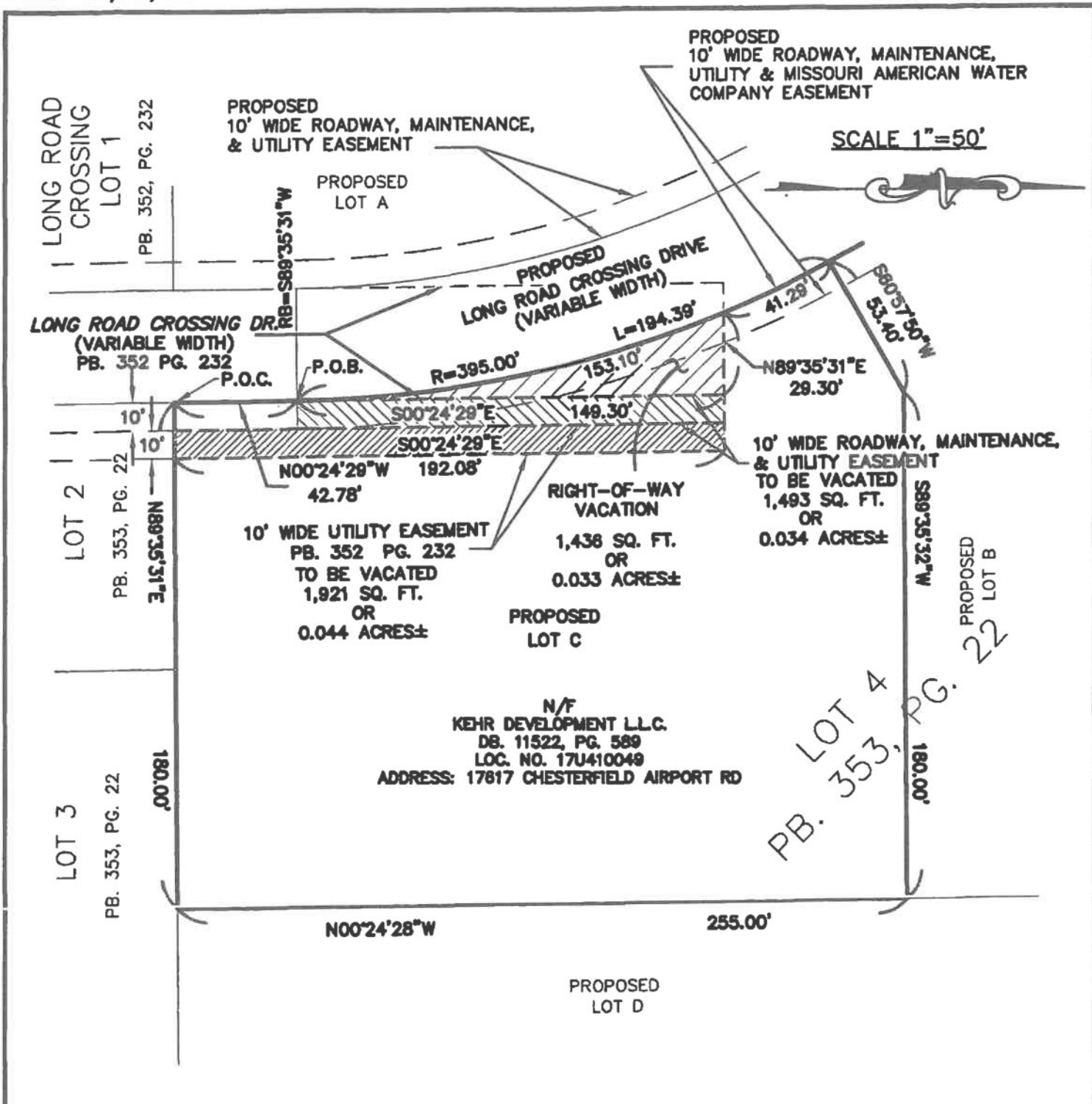
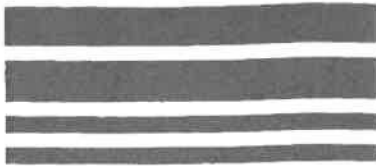

EXHIBIT 'A'

INITIAL:

RIGHT-OF-WAY VACATION PLAT

A TRACT OF LAND BEING PART OF LOT 4 OF LONG ROAD CROSSING LOTS 2, 3, AND 4,
 A RESUBDIVISION OF LONG ROAD CROSSING AS RECORDED IN PLAT BOOK 353, PAGE 22
 LOCATED IN U.S. SURVEY 1010, TOWNSHIP 45 NORTH, RANGE 3 AND 4 EAST
 OF THE 5TH PRINCIPAL MERIDIAN,
 CITY OF CHESTERFIELD, ST. LOUIS COUNTY, MISSOURI



* 2006022401270 *

JANICE M. HAMMONDS, RECORDER OF DEEDS
ST. LOUIS COUNTY MISSOURI
41 SOUTH CENTRAL, CLAYTON, MO 63105

TYPE OF INSTRUMENT
PTL-R

GRANTOR
UNION ELECTRIC CO ETAL

TO

GRANTEE
KEHR DEVELOPMENT L L C

PROPERTY DESCRIPTION:

LONG ROAD CROSSING SUB PLAT LOT 1 PB 352 PG 232

Lien Number

Notation

Locator

NOTE: I, the undersigned Recorder of Deeds, do hereby certify that the information shown on this Certification Sheet as to the TYPE OF INSTRUMENT, the NAMES of the GRANTOR and GRANTEE as well as the DESCRIPTION of the REAL PROPERTY affected is furnished merely as a convenience only, and in the case of any discrepancy of such information between this Certification Sheet and the attached Document, the ATTACHED DOCUMENT governs. Only the DOCUMENT NUMBER, the DATE and TIME of filing for record, and the BOOK and PAGE of the recorded Document is taken from this CERTIFICATION SHEET.

RECORDER OF DEEDS DOCUMENT CERTIFICATION

STATE OF MISSOURI)
SS.
COUNTY OF ST. LOUIS)

Document Number
1,270

I, the undersigned Recorder of Deeds for said County and State, do hereby certify that the following and annexed instrument of writing, which consists of 4 pages, (this page inclusive), was filed for record in my office on the 24 day of February 2006 at 04:15 PM and is truly recorded in the book and at the page number printed above.

In witness whereof I have hereunto set my hand and official seal the day, month and year aforesaid.

JoAnn Reber
Deputy Recorder

Janice M. Hammonds
Recorder of Deeds
St. Louis County, Missouri



Mail to:

[Empty box for mail address]

Destination code: P

- ___ N.P.
- ___ N.P.C.
- ___ N.N.C.
- ___ N.N.I.

RECORDING FEE \$30.00
(Paid at the time of Recording)

3

PARTIAL RELEASE OF EASEMENT

THIS INSTRUMENT made this 14th day of February, 2006.

WHEREAS, UNION ELECTRIC COMPANY d/b/a AmerenUE (hereinafter "AmerenUE") ("Grantor") is the holder, either as original Grantee or as successor in interest to the original Grantee, of that certain Easement granted by KEHR DEVELOPMENT, L.L.C. ("Grantee") dated March 30, 2004, and recorded at Plat Book 352, Page 232, in the Office of the Recorder of Deeds for the County of St. Louis, State of Missouri, affecting the therein described property, to wit:

Parcel A of the Subdivision Plat Lot 1 and Parcel A Long Road Crossing Subdivision in St. Louis County, Missouri.

WHEREAS, it is the purpose of AmerenUE to release that PART of its easement encumbering the PORTION of the premises, said portion being described as:

A variable width strip of land being part of Parcel A of the Subdivision Plat Lot 1 and Parcel A Long Road Crossing Subdivision, being part of Lots 2 and 3 of Damian Kroenungs Estate, U.S. Survey 1010, Township 45 North, Ranges 3 and 4 East, St. Louis County, Missouri; as per plat thereof recorded in Plat Book 352, Page 232 of the St. Louis County, Missouri, Records.

Said variable width strip of land is further illustrated as hachured on the drawing attached hereto marked Exhibit "A" and made a part hereof.

NOW THEREFORE, AmerenUE, in consideration of One Dollar (\$1) and other good and valuable consideration, the receipt of which is hereby acknowledged, does hereby remise and release only that PART of its aforesaid Easement encumbering the PORTION of the premises hereinabove described.

IN WITNESS WHEREOF the said AmerenUE has caused these presents to be executed the day and year first above written.



Assistant Secretary

UNION ELECTRIC COMPANY
d/b/a AmerenUE

By: Dennis W. Weisenborn
Dennis W. Weisenborn
Vice President

STATE OF MISSOURI
CITY OF ST. LOUIS } SS

On the 14th day of February, 2006, before me appeared Dennis W. Weisenborn, to me personally known, who being by me duly sworn, did say that he is a Vice President of Union Electric Company d/b/a AmerenUE and that the seal affixed to the foregoing instrument is the corporate seal of said corporation and that such instrument was signed and sealed in behalf of said corporation by authority of its Board of Directors and said Dennis W. Weisenborn acknowledged said instrument to be the free act and deed of said corporation.

Nannette H. Morton
Notary Public



NHM/rst
Easement No. Long Road Crossing Subd.
PB352/PG232
redocs\ easement\ nhm-proe-kehr dev., llc
Ellisville District
01/30/06

Rev. 12/01

DATE: 12/21/05

PROPOSED JOB NO. 203-3147.5
 10' WIDE ROADWAY, MAINTENANCE,
 UTILITY & MISSOURI AMERICAN WATER
 COMPANY EASEMENT

SCALE 1"=50'

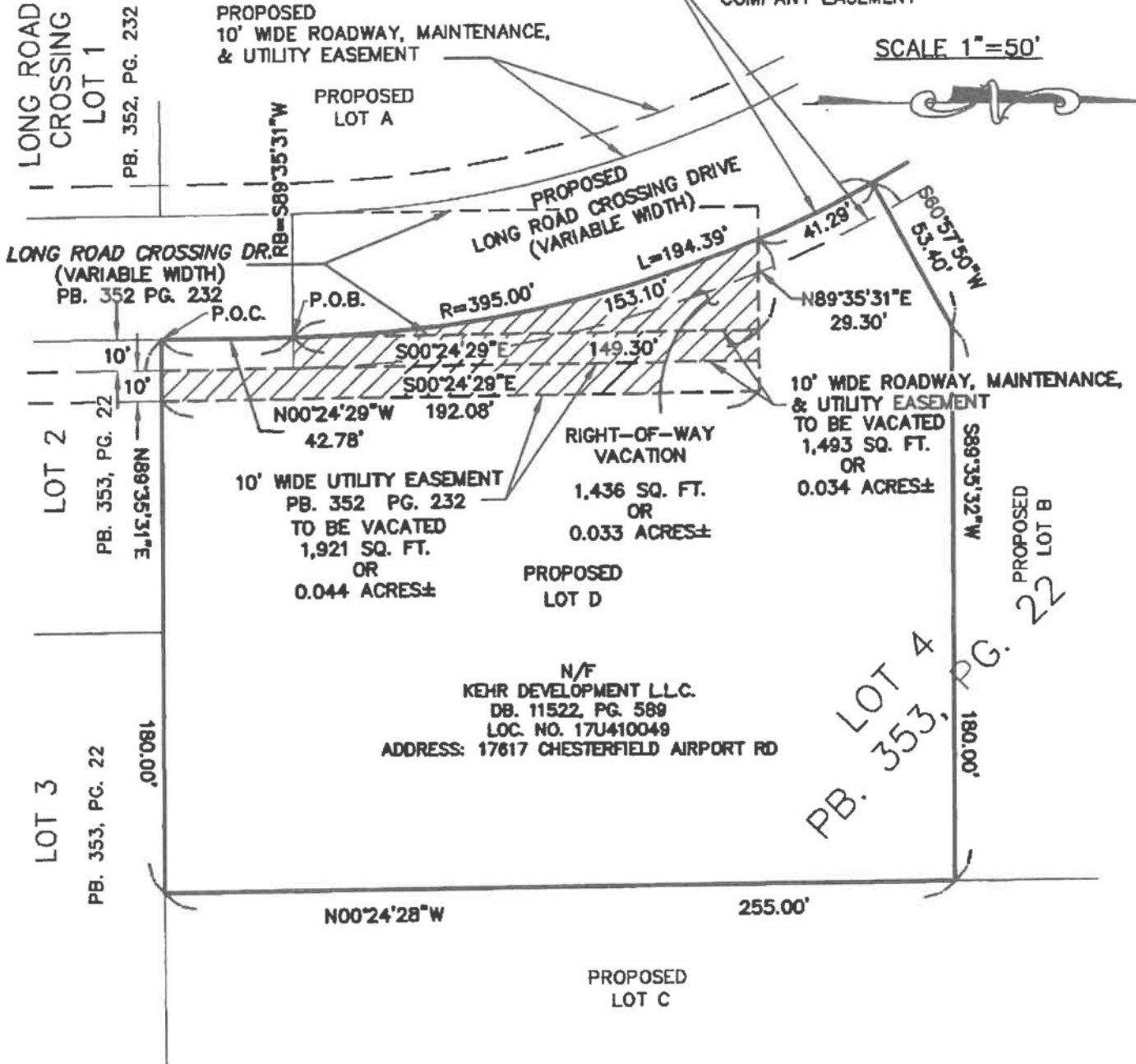

EXHIBIT 'A'

INITIAL:

RIGHT-OF-WAY VACATION PLAT

A TRACT OF LAND BEING PART OF LOT 4 OF LONG ROAD CROSSING LOTS 2, 3, AND 4,
 A RESUBDIVISION OF LONG ROAD CROSSING AS RECORDED IN PLAT BOOK 353, PAGE 22
 LOCATED IN U.S. SURVEY 1010, TOWNSHIP 45 NORTH, RANGE 3 AND 4 EAST
 OF THE 5TH PRINCIPAL MERIDIAN,
 CITY OF CHESTERFIELD, ST. LOUIS COUNTY, MISSOURI



Spire Missouri Inc.
700 Market St.
St. Louis, MO 63101

April 23, 2024

Kehr Development
911 South 13th Street
St. Louis, Missouri 63103

Re: B Street Collision Center at 714 Long Road Crossing Drive (7543)
Request for Right-of-Way Vacation

Right-of-Way Vacation: A portion of Long Road Crossing Drive, as established by Plat Book 352 at Page 232 as located in U.S. Survey 1010, Township 45 North, Ranges 3 & 4 East of the Fifth Principal Meridian, City of Chesterfield, St. Louis County, Missouri.

Ty Gramling, P.E.,

In response to your email dated April 12, 2024, relative to the above referenced right-of-way vacation request.



Please be advised that Spire Missouri Inc. ("Spire") has no facilities located within the area which is requested to be vacated.

Sincerely,



Alex Sammet (Apr 22, 2024 07:14 CDT)

Alex Sammet
Right of Way Area Manager, Missouri
Spire Missouri Inc.

TJF: JAL

Engineering Dept. Approval: 
System Planning Approval: 

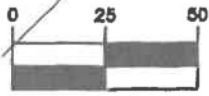
GRAPHIC SCALE



(IN FEET)
1 inch = 50 ft.



N/F
KEHR DEVELOPMENT LLC
LOC #170410214,
714 LONG ROAD CROSSING DR
DB 11522, PG 589

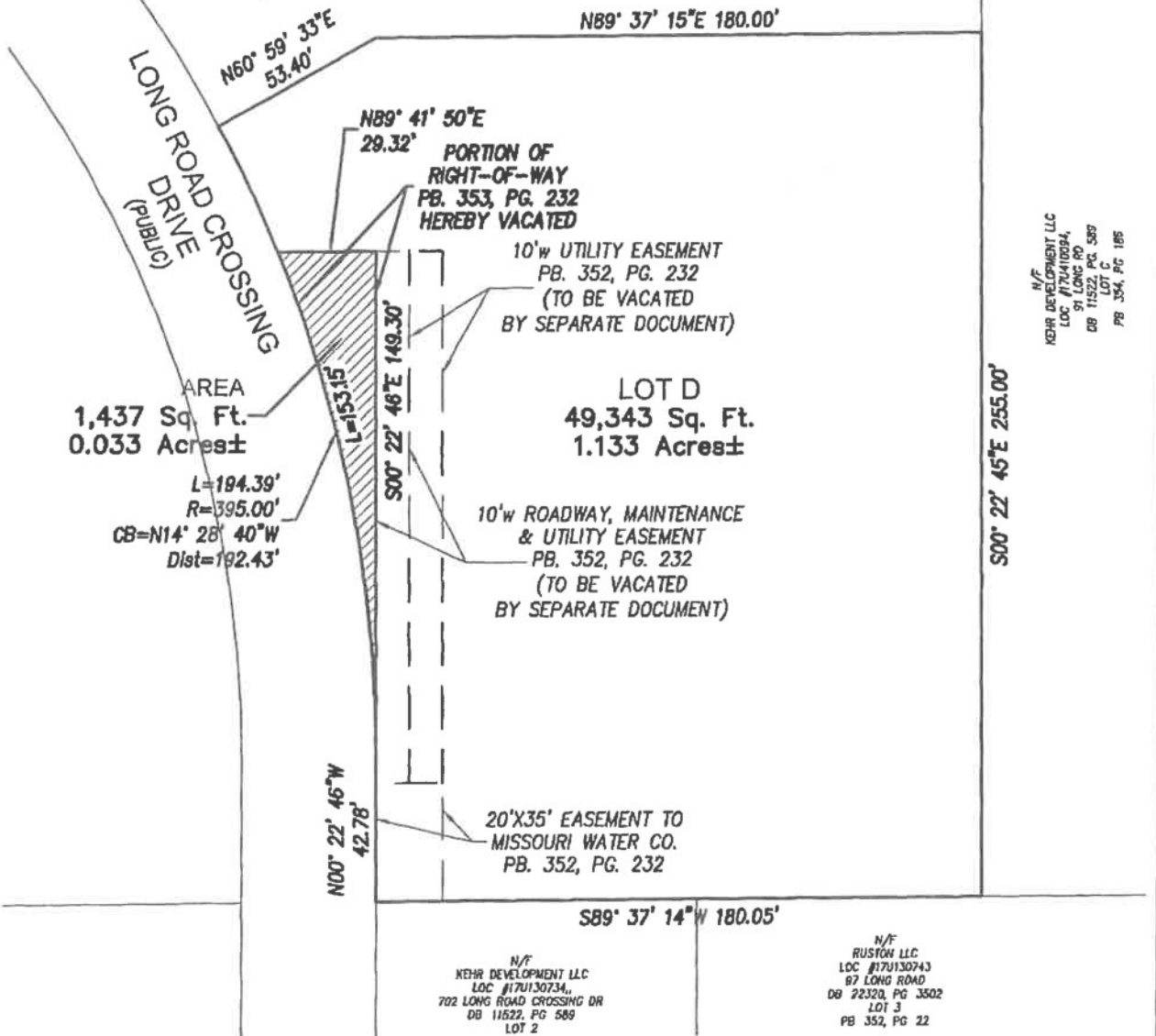

EXHIBIT

RIGHT-OF-WAY VACATION EXHIBIT

A PORTION OF LONG ROAD CROSSING DRIVE, AS ESTABLISHED BY PB. 352, PG. 232, LOCATED IN U.S. SURVEY 1010, TOWNSHIP 45 NORTH, RANGES 3 & 4 EAST OF THE FIFTH PRINCIPAL MERIDIAN, CITY OF CHESTERFIELD, ST. LOUIS COUNTY, MISSOURI

DATE: 4/05/2024

7543/STREET-VAC EXHIBIT.DWG

22



LONG ROAD CROSSING LOTS 2, 3, AND 4 A RESUBDIVISION OF PARCEL A OF LONG ROAD CROSSING

A TRACT OF LAND BEING PARCEL A OF LONG ROAD CROSSING
AS RECORDED BY PLAT BOOK 203, PAGE 232, AND BEING LOCATED IN
U.S. BUREAU TOWNSHIP 45 NORTH, RANGE 3 AND 4 EAST OF THE 9TH PRINCIPAL MERIDIAN
CITY OF CHESTERFIELD IN LOUISIANA



372 v. 22
19th Nov 2015
462

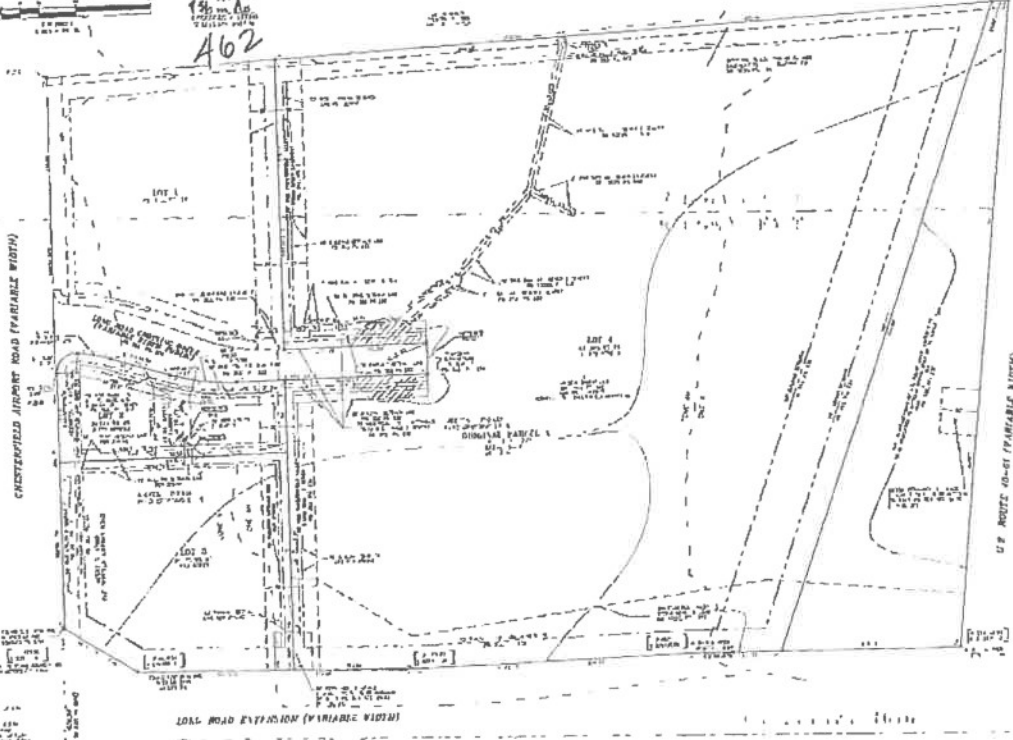

- LEGEND**
- 1. Proposed
 - 2. Existing
 - 3. Easement
 - 4. Right of Way
 - 5. Survey
 - 6. Boundary
 - 7. Easement
 - 8. Right of Way
 - 9. Survey
 - 10. Boundary
 - 11. Easement
 - 12. Right of Way
 - 13. Survey
 - 14. Boundary
 - 15. Easement
 - 16. Right of Way
 - 17. Survey
 - 18. Boundary
 - 19. Easement
 - 20. Right of Way
 - 21. Survey
 - 22. Boundary
 - 23. Easement
 - 24. Right of Way
 - 25. Survey
 - 26. Boundary
 - 27. Easement
 - 28. Right of Way
 - 29. Survey
 - 30. Boundary
 - 31. Easement
 - 32. Right of Way
 - 33. Survey
 - 34. Boundary
 - 35. Easement
 - 36. Right of Way
 - 37. Survey
 - 38. Boundary
 - 39. Easement
 - 40. Right of Way
 - 41. Survey
 - 42. Boundary
 - 43. Easement
 - 44. Right of Way
 - 45. Survey
 - 46. Boundary
 - 47. Easement
 - 48. Right of Way
 - 49. Survey
 - 50. Boundary

ABSTRACT

DESCRIPTION

NOTES

NOTICE TO CONTRACTORS

NOTICE TO ADJACENT OWNERS

NOTICE TO PUBLIC

John Adams
Randy Smith
Barry Tracy

PREPARED FOR
KEIR DEVELOPMENT LLC
11111 N. 20th St., Suite 100
Dallas, TX 75244
214-343-1111

RELEASED BY
DATE
BY

RESUBDIVISION PLAT
PARCEL A OF LONG ROAD CROSSING

STOCK & ASSOCIATES
Consulting Engineers, Inc.

203-3147 1 of 1

186

**RESUBDIVISION OF LOT 4
OF LONG ROAD CROSSING LOTS 2, 3 AND 4
A RESUBDIVISION OF LONG ROAD CROSSING**

A TRACT OF LAND BEING LOT 4 OF LONG ROAD CROSSING LOTS 2, 3 AND 4
AS RECORDED IN PLAT BOOK 268, PAGE 27, AND BEING LOCATED IN
U.S. SURVEY 1010 TOWNSHIP 45 NORTH, RANGE 3 AND 4 EAST OF THE 5TH PRINCIPAL MERIDIAN
CITY OF CHESTERFIELD, ST. LOUIS COUNTY, MISSOURI
THIS PLAT CONTAINS 800 ACRES



517

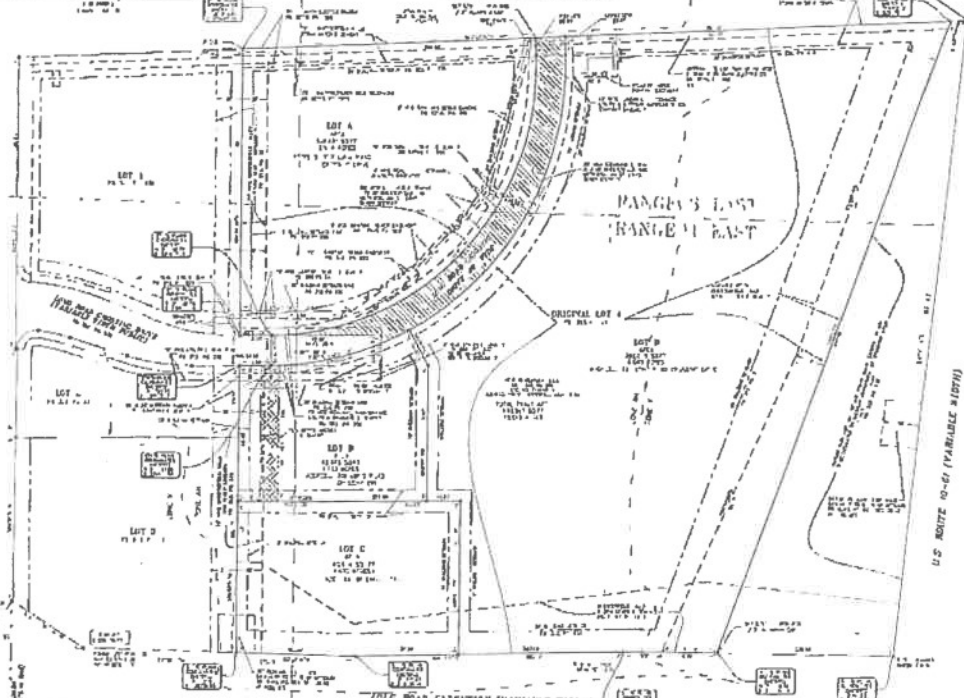
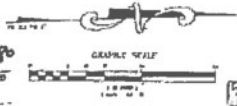

SECTION 1
SECTION 2
SECTION 3
SECTION 4
SECTION 5
SECTION 6
SECTION 7
SECTION 8
SECTION 9
SECTION 10
SECTION 11
SECTION 12
SECTION 13
SECTION 14
SECTION 15
SECTION 16
SECTION 17
SECTION 18
SECTION 19
SECTION 20
SECTION 21
SECTION 22
SECTION 23
SECTION 24
SECTION 25
SECTION 26
SECTION 27
SECTION 28
SECTION 29
SECTION 30
SECTION 31
SECTION 32
SECTION 33
SECTION 34
SECTION 35
SECTION 36
SECTION 37
SECTION 38
SECTION 39
SECTION 40
SECTION 41
SECTION 42
SECTION 43
SECTION 44
SECTION 45
SECTION 46
SECTION 47
SECTION 48
SECTION 49
SECTION 50
SECTION 51
SECTION 52
SECTION 53
SECTION 54
SECTION 55
SECTION 56
SECTION 57
SECTION 58
SECTION 59
SECTION 60
SECTION 61
SECTION 62
SECTION 63
SECTION 64
SECTION 65
SECTION 66
SECTION 67
SECTION 68
SECTION 69
SECTION 70
SECTION 71
SECTION 72
SECTION 73
SECTION 74
SECTION 75
SECTION 76
SECTION 77
SECTION 78
SECTION 79
SECTION 80

ADDITIONAL NOTES
1. ALL DISTANCES ARE IN FEET AND DECIMALS THEREOF.
2. ALL BEARINGS ARE TRUE BEARINGS.
3. ALL CURVES ARE CIRCULAR UNLESS OTHERWISE NOTED.
4. ALL CORNERS ARE TO BE MARKED WITH IRON PIPES OR STEEL BOLTS.
5. ALL DISTANCES ARE TO BE MEASURED ALONG THE CENTERLINE OF THE ROAD.
6. ALL DISTANCES ARE TO BE MEASURED ALONG THE CENTERLINE OF THE ROAD.
7. ALL DISTANCES ARE TO BE MEASURED ALONG THE CENTERLINE OF THE ROAD.
8. ALL DISTANCES ARE TO BE MEASURED ALONG THE CENTERLINE OF THE ROAD.
9. ALL DISTANCES ARE TO BE MEASURED ALONG THE CENTERLINE OF THE ROAD.
10. ALL DISTANCES ARE TO BE MEASURED ALONG THE CENTERLINE OF THE ROAD.

MISSOURI COUNTY RECORDS
RECORDED
RECORDED

ALL DISTANCES ARE TO BE MEASURED ALONG THE CENTERLINE OF THE ROAD.
ALL DISTANCES ARE TO BE MEASURED ALONG THE CENTERLINE OF THE ROAD.
ALL DISTANCES ARE TO BE MEASURED ALONG THE CENTERLINE OF THE ROAD.
ALL DISTANCES ARE TO BE MEASURED ALONG THE CENTERLINE OF THE ROAD.
ALL DISTANCES ARE TO BE MEASURED ALONG THE CENTERLINE OF THE ROAD.
ALL DISTANCES ARE TO BE MEASURED ALONG THE CENTERLINE OF THE ROAD.
ALL DISTANCES ARE TO BE MEASURED ALONG THE CENTERLINE OF THE ROAD.
ALL DISTANCES ARE TO BE MEASURED ALONG THE CENTERLINE OF THE ROAD.
ALL DISTANCES ARE TO BE MEASURED ALONG THE CENTERLINE OF THE ROAD.
ALL DISTANCES ARE TO BE MEASURED ALONG THE CENTERLINE OF THE ROAD.

PREPARED FOR
KEHR DEVELOPMENT, LLC
BY
STOCK & ASSOCIATES
CONSULTING ENGINEERS, INC.

LONG ROAD INTENTION (VARIABLE WIDTH)
U.S. SURVEY 1010
U.S. SURVEY 106

U.S. SURVEY 1010
U.S. SURVEY 106

U.S. SURVEY 1010
U.S. SURVEY 106

U.S. SURVEY 1010
U.S. SURVEY 106

U.S. SURVEY 1010
U.S. SURVEY 106

RESUBDIVISION PLAT			
LOT 4 OF LONG ROAD CROSSING LOTS 2, 3 AND 4			
STOCK & ASSOCIATES		CONSULTING ENGINEERS, INC.	
DATE	BY	SCALE	SHEET NO.
11/12/12	J. S. [Signature]	AS SHOWN	1 OF 1

CLT J303 791
283416

BP 11522/0598
2

GENERAL WARRANTY DEED
(PARTNERSHIP)

THIS DEED, made and entered into this 27th day of March, 1998 by and between Airport Tract Joint Venture, a Missouri general partnership

of the County of St. Louis, State of Missouri party or parties of the first part, and Kehr Development, L.L.C., a Missouri limited liability company
Address: 13334 Fairfield Square, Chesterfield, MO 63017

of the County of St. Louis, State of Missouri party or parties of the second part.

WITNESSETH, that the said party or parties of the first part, for and in consideration of the sum of One Dollar and other valuable considerations paid by the said party or parties of the second part, the receipt of which is hereby acknowledged, does or do by these presents GRANT, BARGAIN and SELL, CONVEY and CONFIRM unto the said party or parties of the second part, the following described Real Estate, situated in the County of St. Louis and State of Missouri, to-wit:

A tract of land being part of U.S. Survey 1010, Township 45 North, Range 3 and 4 East in St. Louis County, Missouri and more particularly described as follows: Beginning at point, said point being the intersection of the South line of U.S. Highway 40 and the West line of Long Road extension; thence South 00 degrees 17 minutes 01 seconds East, 363.77 feet; thence South 02 degrees 33 minutes 39 seconds East, 362.64 feet; thence South 00 degrees 02 minutes 24 seconds West, 370.26 feet; thence South 30 degrees 20 minutes 35 seconds West 113.94 feet to the North line of Old Olive Street Road; thence South 88 degrees 27 minutes 29 seconds West, 721.27 feet; thence North 03 degrees 36 minutes 57 seconds West, 1285.85 feet; thence South 85 degrees 17 minutes 53 seconds East, 844.76 feet to the point of beginning.

Subject to building lines, conditions, restrictions, easements and zoning regulations of record if any.

TO HAVE AND TO HOLD the same, together with all rights and appurtenances to the same belonging, unto the said party or parties of the second part, and to the heirs and assigns of such parties forever.

The said party or parties of the first part hereby covenanting that said party or parties and the heirs, executors and administrators of such party or parties, shall and will WARRANT AND DEFEND the title to the premises unto the said party or parties of the second part, and to the heirs and assigns of such party or parties forever, against the lawful claims of all persons whomsoever, excepting, however, the general taxes for the calendar year 1998 and thereafter, and special taxes becoming a lien after the date of this deed.

IN WITNESS WHEREOF, the said party or parties of the first part has or have hereunto set their hand or hands the day and year first above written.

Airport Tract Joint Venture, a
Missouri general partnership

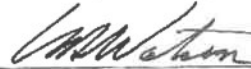

By: Amos D. Watson, Majority Partner

FLORIDA
STATE OF MISSOURI)
MARCO BIAN) ss. On this 27th day of March, 1998 before me personally
CITY OF ST. LOUIS)

appeared Amos D. Watson being partners of Airport Tract Joint Venture, a Missouri General Partnership to me known to be the Partnership described the foregoing instrument, and acknowledged that they executed the same as the free act and deed of said Partnership.

IN TESTIMONY WHEREOF, I have hereunto set my hand and affixed my official seal in the County and State aforesaid, the day and year first above written.



LESLIE A DRAKE
My Commission CC510558
Expires Dec 18, 1999

Leslie A. Drake
Notary Public

My term expires:

MASTER CHANNEL CROSS SECTIONS

MASTER CHANNEL SECTION (NORTH)

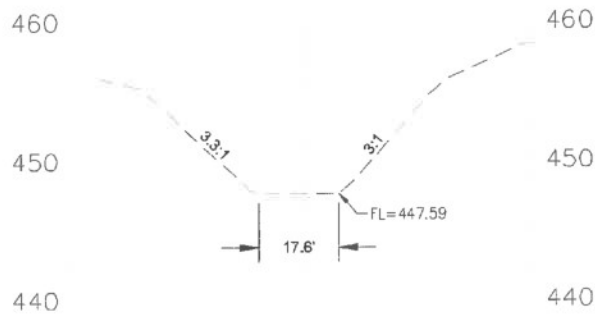

MASTER CHANNEL SECTION (NORTH)

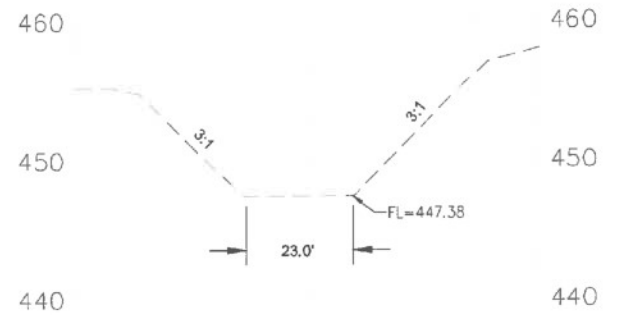

MASTER CHANNEL SECTION (EAST)

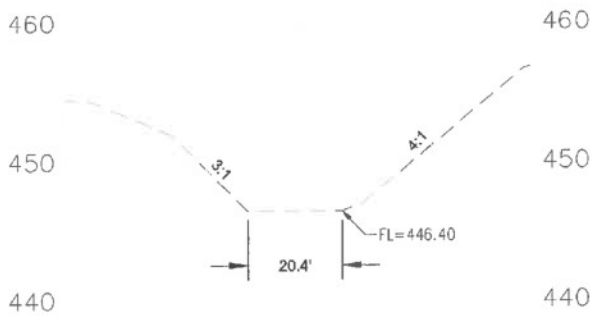

MASTER CHANNEL SECTION (EAST)

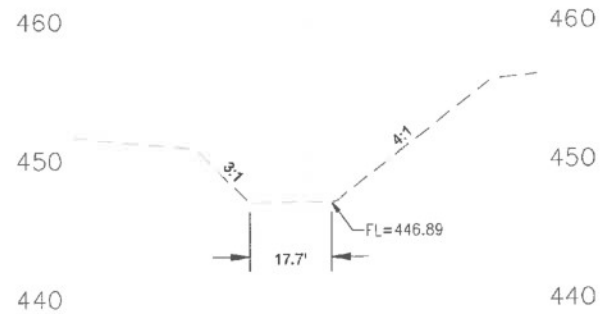

MASTER CHANNEL SECTION (EAST)

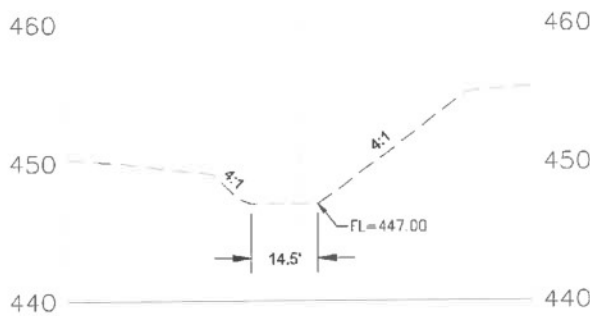

GRAPHIC SCALE

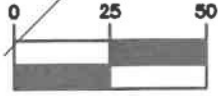

(IN FEET)
1 inch = 50 ft.



N/F
KEHR DEVELOPMENT LLC
LOC. #17U10214
714 LONG ROAD CROSSING DR
DB. 11522, PG. 589

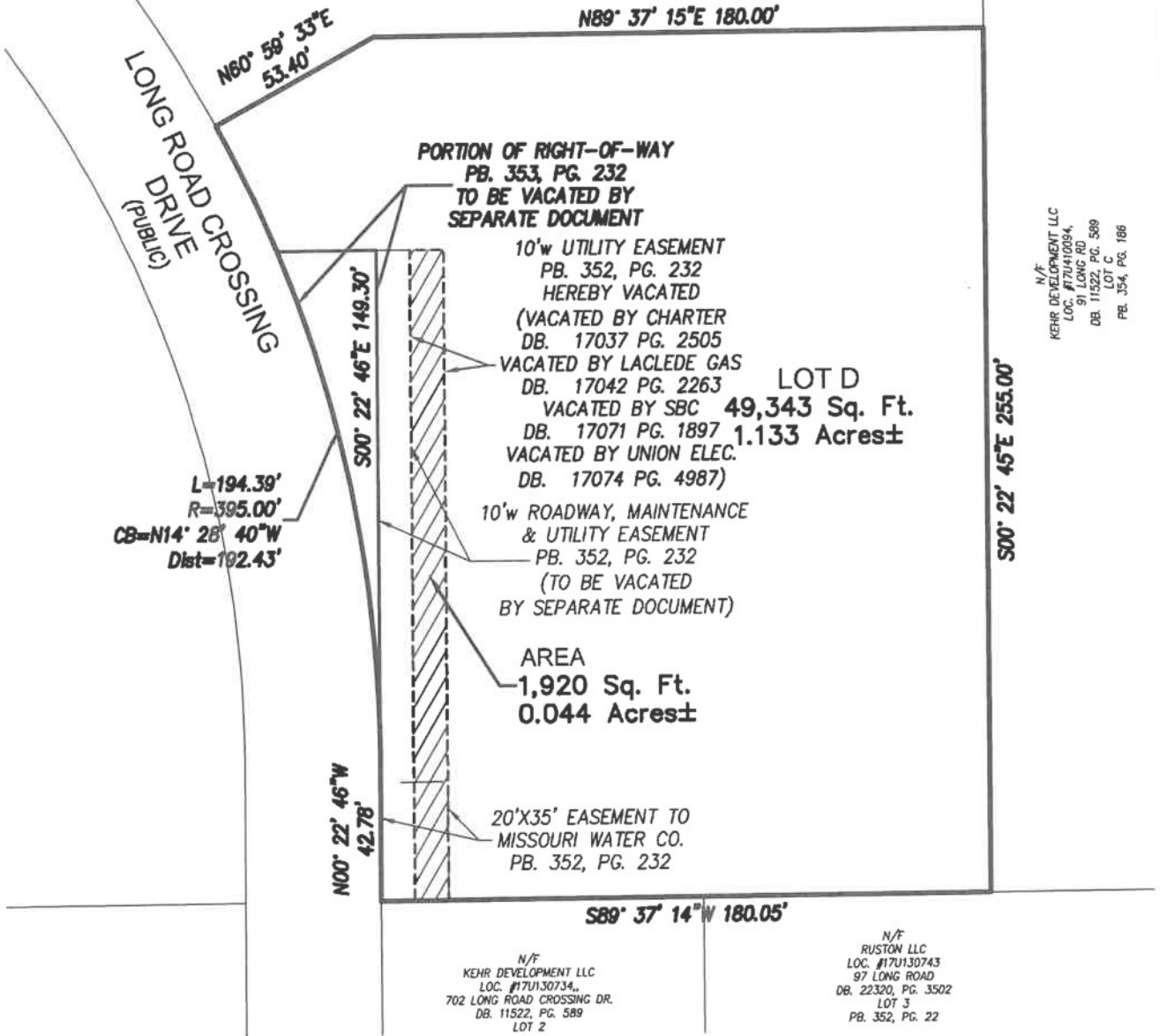

N/F
KEHR DEVELOPMENT LLC
LOC. #17U10094
91 LONG RD
DB. 11522, PG. 589
LOT C
PB. 354, PG. 166

N/F
KEHR DEVELOPMENT LLC
LOC. #17U130734
702 LONG ROAD CROSSING DR.
DB. 11522, PG. 589
LOT 2

N/F
RUSTON LLC
LOC. #17U130743
97 LONG ROAD
DB. 22320, PG. 3502
LOT 3
PB. 352, PG. 22

EXHIBIT

EASEMENT VACATION EXHIBIT

PORTION OF UTILITY EASEMENT, AS ESTABLISHED BY PB. 352, PG. 232,
LOCATED IN U.S. SURVEY 1010, TOWNSHIP 45 NORTH, RANGES 3 & 4
EAST OF THE FIFTH PRINCIPAL MERIDIAN,
CITY OF CHESTERFIELD, ST. LOUIS COUNTY, MISSOURI