

ORDINANCE NO.7079

AN ORDINANCE AMENDING CHAPTER 30 OF THE GARLAND CODE OF ORDINANCES, CHAPTER 34 OF THE GARLAND CODE OF ORDINANCES, AND THE GARLAND DEVELOPMENT CODE OF THE CITY OF GARLAND, TEXAS; PROVIDING A SAVINGS CLAUSE; PROVIDING A PENALTY UNDER THE PROVISIONS OF SECTION 10.05 OF THE CODE OF ORDINANCES OF THE CITY OF GARLAND, TEXAS; PROVIDING A SEVERABILITY CLAUSE; AND SETTING AN EFFECTIVE DATE.

BE IT ORDAINED BY THE CITY COUNCIL OF THE CITY OF GARLAND, TEXAS:

**Section 1**

That Section 30.02, "Amendments, modifications and deletions", of Chapter 30, "Building Inspection", of the Code of Ordinances of the City of Garland, Texas, is hereby amended to read as follows:

**"Section 30.02 Amendments, modifications and deletions**

The following sections of the International Building Code, as adopted in [Section 30.01](#) above, are amended as described below:

Section 101.1 Title shall be amended to read as follows:

101.1 Title. These regulations shall be known as the Building Code of the City, hereinafter referred to as "the Building Code."

Section 101.4 Referenced Codes, shall be amended to read as follows:

101.4 Referenced Codes. The other Codes listed in sections 101.4.1 thru 101.4.8 and referenced elsewhere in the Building Code, when specifically adopted, shall be considered part of the requirements of the Building Code to the prescribed extent of each such reference. Whenever amendments have been adopted to the referenced Codes and standards, each reference to that Code or standard shall be considered to reference the amendments as well. Any reference to the International Electrical Code or NFPA 70

shall mean the Electrical Code as adopted and amended by the Code of Ordinances.

Section 101.4.4 Property maintenance shall be amended to read as follows:

101.4.4 Property maintenance. The provisions of the International Property Maintenance Code shall apply to existing nonresidential structures and premises; equipment and facilities; light, ventilation, space heating, sanitation, life and fire safety hazards; responsibilities of owners, operators and occupants; and occupancy of existing nonresidential premises and structures.

Section 101.4.7 Existing buildings shall be amended to read as follows:

101.4.7 Existing buildings. Repair, alternations, additions, relocation and changes in occupancy shall conform to the provisions of this Code for a new building. As an alternate method of construction and in conformance with section 104.11 an applicant may submit for approval a design in conformance with the International Existing Building Code. Such design may be approved by the Building Official provided the proposed design is satisfactory and complies with the intent of the provisions of this Code.

Section 101.4.8 Electrical shall be added to read as follows:

101.4.8 Electrical. The provisions of the Electrical Code shall apply to the installation of electrical systems, including alterations, repairs, replacement, equipment, appliances, fixtures, fittings and appurtenances thereto.

Section 103.1 Creation of enforcement agency shall be amended to read as follows:

103.1 Creation of enforcement agency. The Building Inspection Department shall enforce the provisions of this Code. The official in charge shall be the Building Official.

Section 105.2 Work exempt from permit shall be amended to read as follows:

First paragraph remains unchanged.

Building.

1. One-story detached accessory structures used as tool and storage sheds, playhouses and similar uses, provided the floor area does not exceed 20 square feet.
2. Oil derricks.
3. Retaining walls which are not over 4 feet in height measured from the bottom of the footing to the top of the wall, unless supporting a surcharge or impounding class I, II, or III-A liquids.
4. Painting, papering, tiling, carpeting, cabinets, counter tops and similar finish work.
5. Temporary motion picture, television and theater stage sets and scenery.
6. Prefabricated swimming pools accessory to a group R-3 occupancy that are less than 24 inches deep, do not exceed 5,000 gallons, and are installed entirely above ground.
7. Swings and other playground equipment accessory to detached one- and two-family dwellings.
8. Movable cases, counters and partitions not over 5 feet 9 inches in height.
9. Uncovered decks not over 30 inches in height above grade.
10. Minor foundation repair and roof repair of less than \$2,000.00.

Section 105.5 Expiration shall be amended to read as follows:

105.5 Expiration. An individual permit issued by the Building Official shall expire by limitation and become null and void on the expiration of 2 years after its issuance if no progress has been made toward the completion of the project, or upon expiration of the project. (A project shall expire immediately after the fifth anniversary of the date the first permit application was filed for the project if no progress had been made towards completion of the project.) Once a permit for particular work has expired, a new permit must be applied for and obtained before the work can be commenced. The permit fee shall be the full amount required for a new permit for such work. The Building Official or his designee shall determine the extent to which the work must comply with any new regulations that were not in effect at the time the original permit was issued.

Section 107.1 General shall be amended by adding a new paragraph to the end of that section to read as follows:

A state-licensed architect shall prepare documents on all group E, division 3 daycare facilities over 5,000 square feet.

Section 107.2 Construction documents shall be amended by adding new subsections 107.2.7, 107.2.8 and 107.2.9 to read as follows:

107.2.7 Asbestos survey. An applicant for all public or commercial building renovation or demolition permits must provide evidence of an asbestos survey prior to the issuance of the permit.

107.2.8 TDLR-AB review. Plans and specifications shall be submitted to the Texas Department of Licensing and Regulation ("TDLR") for review prior to submittal for review or permitting. Verification of project registration with TDLR shall be required prior to permit.

107.2.9 Stormwater pollution prevention plan. A stormwater pollution prevention plan ("SWPPP")

may be required in accordance with state, federal and local statute.

Section 109 Fees shall be amended by adding subsections 109.7, 109.8, 109.8.1, 109.8.2 and 109.9 [sic] to read as follows:

109.7 Reinspection fee. A fee as established by City Council resolution may be charged when:

1. The inspection called for is not ready when the inspector arrives;
2. No building address or permit card is clearly posted;
3. City approved plans are not on the jobsite available to the inspector;
4. The building is locked or work otherwise not available for inspection when called;
5. The jobsite is red-tagged twice for the same item;
6. The original red tag has been removed from the jobsite.
7. Failure to maintain erosion control, trash control or tree protection.
8. Work is concealed without required inspection.
9. The applicant fails to provide means of access to the area subject to inspection. Any reinspection fees assessed shall be paid before any more inspections are made on that jobsite.

109.8 Work without a permit.

109.8.1 Preliminary inspection. Whenever work for which a permit is required by this Code has been commenced without first obtaining a permit, a preliminary inspection may be made before a permit may be issued for such work.

109.8.2 Fees. Permit fees may be doubled when work is commenced prior to obtaining a permit.

Section 110.3.8 Other inspections shall be amended by adding a sentence to the end of that section to read as follows:

A stormwater pollution prevention plan ("SWPPP") and inspection may be required.

Section 111 Certificate of occupancy is amended in its entirety to read as follows:

SECTION 111 CERTIFICATE OF OCCUPANCY.

111.1 Use or occupancy. A building or structure shall not be used or operated, and a change in the existing use or occupancy classification of a building or structure or a portion thereof shall not be made, until the Building Official has issued a certificate of occupancy therefor as provided herein. Issuance of a certificate of occupancy shall not be construed as an approval of a violation of the provisions of this Code or of other ordinances of the jurisdiction. Dwellings are exempted from the foregoing requirements.

The Building Inspection Department may issue a single certificate of occupancy for multi-tenants in one lease space or building when the occupants share common areas or staff and related activities which are under the control of a single person or business.

A certificate of occupancy shall be obtained for a building, structure or land when there is a change in classification of use as provided by the Garland Development Code (GDC) when there is a change as provided by the Building Code, or when there is a change in tenants of the building, structure or land.

111.2 Certificate issued. After all necessary inspections have been conducted by the City and when it is determined that there is no probable

cause to believe that the buildings, structures or land do not comply with an applicable provision of the Code of Ordinances, the Building Official shall issue a certificate of occupancy containing the following:

- (1) The address of the location of the building, structure or land.
- (2) The name of the tenant occupying or using the building, structure, or land.
- (3) A statement as to the approved use of the building, structure or land.
- (4) The allowable occupant load for assembly uses.
- (5) Any other information deemed necessary by the Building Inspection Department.

Approved use is based upon an applicant's representations as to the use of the building, structure, or land. The use approved by the Building Official does not authorize any unlawful use of the building, land, or structure even if the City issues the certificate of occupancy.

111.3 Temporary occupancy. The Building Official is authorized to issue a temporary certificate of occupancy before the completion of the entire work covered by the permit, provided that such portion or portions shall be occupied safely. The Building Official shall set a time period during which the temporary certificate of occupancy is valid.

111.4 Revocation. The Building Official may suspend or revoke a certificate of occupancy when it is determined it was issued in error or on the basis of incorrect information; in the event of an unapproved addition or change in use or occupancy of the building, structure, land or any part thereof; or when it is determined that the building, structure, land or any portion thereof is in violation of any ordinance or regulation, or any provision of the applicable Zoning,

Building or Fire Codes.

111.5 Posting. The certificate of occupancy shall be posted in a conspicuous place on the premises and shall not be removed except by the Building Official.

111.6 Fee. At the time that an application is made for a certificate of occupancy, a fee in the amount prescribed in the fee schedule ([section 30.301](#) of chapter 30 of the Code of Ordinances) shall be paid.

Section 113 is amended in its entirety to read as follows:

SECTION 113 UNIFIED BUILDING STANDARDS COMMISSION.

113.1 Appeals. Any person aggrieved by any orders, decisions or determinations made by the Fire Code Official or the Building Official relative to the application and interpretation under the provisions of this Code, shall have the right to make an appeal to the Unified Building Standards Commission ("Commission").

113.2 Time for filing appeal. The appeal must be in writing and received in the office of the Building Official within 30 days of the decision or ruling to be appealed, and must set forth the specific grounds for the appeal. The Building Official shall forward the appeal to the Commission, along with all material information constituting the record up which the decision was made.

113.3 Notice of hearing. The Commission shall meet upon notice from the Chairman and within 30 days of the date the appeal was filed with the Building Official.

113.4 Decision of Commission. The Commission shall render a written decision affirming, modifying, or reversing the decision of the Building Official, in whole or in part, within 30 days of the hearing, and may issue appropriate orders consistent with its decision. All

decisions of the Commission shall be by a majority vote. The minutes of the meeting shall reflect how each of the Commission members participating in the decision voted. The decision of the Commission shall be filed promptly in the office of the Building Official and with the City Secretary. The Building Official shall be responsible for the enforcement of the Commission's decisions.

113.5 Commission composition.

113.5.1 Composition. The Commission shall consist of a minimum of 9 voting members who shall be appointed by the City Council. To be eligible for an appointment, a person must be resident of the City and must have resided within the City for a minimum of one (1) year prior to his or her appointment. The Commission shall consist of one qualified person with training and experience in the each of the following industries:

- (a) a member of the public;
- (b) architecture or technical design;
- (c) engineering;
- (d) commercial contracting;
- (e) a person with training and experience to pass on matters pertaining to hazards of fire, explosions, hazardous conditions or fire protection systems;
- (f) plumbing;
- (g) HVAC/mechanical contracting; and
- (h) electrical.

113.5.2 Terms. The term of office for members of the Commission shall be 2 years. The Building Official or his designee shall be an ex officio member of the Commission, without voting privileges.

113.5.3 Compensation. The members of the Commission shall serve without compensation.

113.5.4 Secretary. The Building Official or his or her designee shall act as secretary to the Commission, and shall be responsible for keeping written minutes, or an audio recording, of meetings.

113.5.5 Election of officers. The Commission shall elect by a majority vote persons desiring to serve as Chairman or Vice-Chairman of the Commission. Elections shall be held upon on a motion of a member of the Commission when seconded by another member. However, there shall not be more than one election per year except where the office is vacated.

113.6 Powers and duties.

113.6.1 Generally. The Commission shall meet upon call of the Chairman to consider proposed revisions to this Code, as needed for the consideration of appeals of decisions of the Building Official, to consider the time period of suspension of a person's ability to secure permits, or to perform other duties assigned to the Commission by the Code of Ordinances.

113.6.2 Amendments. The Commission shall recommend to the City Council amendments to [Chapter 30](#) of the Code of Ordinances and the Fire Code provisions of [Chapter 21](#) of the Code of Ordinances. Any interested person may submit proposed amendments to the Commission. The Commission shall consider the recommendation of the Building Official concerning any proposed amendment. In order for the Commission to recommend an amendment to the City Council, a concurring vote of two-thirds (2/3) of the members of the Commission present at the meeting is required.

113.6.3 Appeals. The Commission shall have the authority to hear appeals of decisions or rulings of the Building Official made under the provisions of the Building Code, Energy

Conservation Code and chapters 1-11 of the Residential Code. The Commission shall have the authority to hear appeals of decisions or rulings of the Fire Marshal made under the provisions of the Fire Code. In that connection, the Commission shall have the limited power to determine whether the true intent of these Codes and the rules adopted thereunder have been correctly interpreted, whether the provisions of these Codes apply fully, or whether an equally good or better form or construction or material was proposed and may be used. The Commission shall have no power to limit, modify, change or waive any requirement of these Codes.

113.6.4 Suspension of permit privileges. A person's ability to secure permits may be suspended by the Building Official for a period specified by the Commission, for any of the following causes:

- (a) The person fails to finalize permits by obtaining the required approved inspections.
- (b) The person allows use or occupancy of the structure or facility without first obtaining the required authorization.
- (c) The person has been found by the Board to have been grossly negligent in the performance of the work.
- (d) Expiration, suspension or revocation of required license, bond or insurance.

113.7 Statutory Construction. Any reference to the following boards or commissions within this Code, or any board of appeals in a model code adopted by this Code of Ordinances, shall mean the Unified Building Standards Commission:

- (a) Building and Fire Codes Board,
- (b) Electrical Appeals Board,
- (c) Mechanical Appeals Board,

- (d) Plumbing Appeals Board,
- (e) Fuel and Gas Appeals Board,
- (f) Residential Appeals Board, or
- (g) Energy Conservation Appeals Board.

113.8 Conflict. To the extent that there is any express conflict between the provisions of this Code and any national or international model code adopted herein, the provisions of this Code shall control.

Section 117 Working hours, shall be added to read as follows:

SECTION 117 WORKING HOURS.

117.1 Hours established. Any outside work being done adjacent to an occupied residential subdivision or adjacent to an occupied residential use, including multifamily uses, shall be allowed only between 7:00 a.m. and 8:00 p.m. each day of the week. Any outside work being done adjacent to an occupied residential subdivision or adjacent to an occupied residential use, including multifamily uses, shall be prohibited between 8:00 p.m. and 7:00 a.m. each day of the week.

117.2 Other regulations unaffected. This section does not authorize violation of any other law or regulation.

117.3 Exceptions. These regulations do not affect emergency work being done to secure a structure or to reestablish utility service to a structure.

117.4 Variance. The director of health, in accordance with [section 22.76](#) of the Code of Ordinances, may issue a permit of variance to these regulations.

Section 202 Definitions shall be amended by changing the following definitions of to read as follows:

ATRIUM. An opening connecting three or more stories other than enclosed stairways, elevators, hoistways, escalators, plumbing, electrical, air-conditioning or other equipment, which is closed at the top and not defined as a mall. Stories, as used in this definition, do not include balconies within assembly groups or mezzanines that comply with section 505 of the Building Code.

AMBULATORY CARE FACILITY. Buildings or portions thereof used to provide medical, surgical, psychiatric, nursing or similar care on a less than 24-hour basis to individuals who are rendered incapable of self-preservation by the services provided. This group may include but not be limited to the following:

- Dialysis centers
- Sedation dentistry
- Surgery centers
- Colonic centers
- Psychiatric centers

ASSISTED LIVING FACILITIES. A building or part thereof housing persons, on a 24-hour basis, who because of age, mental disability or other reasons, live in a supervised residential environment which provides personal care services. The occupants are capable of responding to an emergency situation without physical assistance from staff.

HIGH-RISE BUILDING. A building having floors used for human occupancy located more than 55 feet above the lowest level of Fire Department vehicle access.

REPAIR GARAGE. A building, structure or portion thereof used for servicing or repairing motor vehicles. This occupancy shall also include garages involved in minor repair, modification and servicing of motor vehicles for items such as lube changes, inspections, windshield repair or replacement, shocks, minor part replacement and other such minor repairs.

SPECIAL INSPECTOR. A qualified person employed or retained by an approved agency who shall prove to the satisfaction of the registered design professional in responsible charge and the Building Official as having the competence necessary to inspect a particular type of construction requiring special inspection.

Section 303.1.3 Associate the group E occupancies shall be amended to read as follows:

303.1.3 Associated with group E occupancies. A room or space used for assembly purposes that is associated with a group E occupancy is not considered a separate occupancy. Except when applying the assembly requirements of chapter 10 and 11.

Section 304.1 Business group shall be amended by adding the following two uses to the list of occupancies types:

Fire stations;

Police stations with detention facilities for 5 or less.

Section 307.1.1 Uses other than group H shall be amended to add the following sentence to exception 4:

4. Cleaning establishments... {Text unchanged} ...with section 707 or 1-hour horizontal assemblies constructed in accordance with section 711 or both. See also IFC chapter 21, dry cleaning plant provisions.

Section 403.1 Applicability shall be amended to read as follows:

403.1 Applicability. The provisions of this section shall apply to buildings having any occupied floors located more than 55 feet above the lowest level of Fire Department vehicle access. High-rise buildings shall comply with sections 403.2 through 403.6.

Section 403.1, exception 3 shall be amended to read as

follows:

3. The open air portion of a building

{remainder unchanged}

Section 403.3.2 Water supply to required fire pumps shall be amended to read as follows:

403.3.2 Water supply to required fire pumps. In buildings that are more than 120 feet (36.5 m) in building height, required fire pumps shall be supplied by connections to no fewer than two water mains located in different streets. Separate supply piping shall be provided between each connection to the water main and the pumps. Each connection and the supply piping between the connection and the pumps shall be sized to supply the flow and pressure required for the pumps to operate.

Exception: {No change to exception.}

Section 403.5.4 Smokeproof enclosures shall be amended to read as follows:

403.5.4 Smokeproof enclosures. Every required interior exit stairway serving floors more than 55 feet above the lowest level of Fire Department vehicle access shall be a smokeproof enclosure in accordance with sections 909.20 and 1023.10.

Section 404.5 Smoke control shall be amended by deleting the exception in its entirety.

Section 406.3.5.1 Carport separation shall be amended to read as follows:

406.3.5.1 Carport separation. A separation is not required between a group R-2 and U carport provided that the carport is entirely open on all sides and that the distance between the two is at least 10 feet.

Section 406.8 Repair garages shall be amended by adding a second paragraph at the end of the section to read as follows:

This occupancy shall include garages involved in the servicing of motor vehicles such as oil and lubricant changes, inspections, windshield repair or replacement, shock absorbers, minor part replacement, and other such nonmajor repair. When the garage is only involved in such minor repair, it need not comply with section 406.8.1 of the Building Code.

Section 506.3.1 Minimum percentage of perimeter shall be amended by adding a sentence to the end of the section to read as follows:

In order to be considered as accessible, if not in direct contact with a street or fire lane, a minimum 10-foot wide pathway from the street or approved fire lane must be provided. (See the International Fire Code, as adopted and amended by the Code of Ordinances, for hose lay measurement pathway requirements.)

Table 508.4 Required separation of occupancies (hours) shall be amended by adding a new exception "f" to read as follows:

f. Unless waived by the Building Official, a 1-hour tenant separation wall is required between tenants in all occupancies. Protection of openings may be waived if the building is classified as "nonseparated uses" in accordance with section 302.3 of the Building Code.

Table 705.8 Maximum area of exterior wall openings based on fire separation distance and degree of opening protection shall be amended by adding a sentence to the end of footnote "f" to read as follows:

Open metal carport structures may be constructed on the property line without fire-resistive or opening protection when the location of the carport is allowed or approved as provided by the Code of Ordinances.

Section 806.3 Combustible decorative materials shall be

amended to read as follows:

806.3 Combustible decorative materials. In occupancies in groups A, E, I, and R-1, and dormitories in group R-2, curtains, draperies, fabric hangings and other similar combustible decorative materials suspended from walls or ceilings shall comply with section 806.4 and shall not exceed 10 percent of the specific wall or ceiling area to which they are attached.

Section 901.5.1 Acceptance testing is amended to add section 901.5.1.1 to read as follows:

901.5.1.1 Standpipe testing. Building owners/managers must maintain and test standpipe systems as per NFPA 25 requirements. The following additional requirements shall be applied to the testing that is required every 5 years:

1. The piping between the Fire Department connection (FDC) and the standpipe shall be backflushed when foreign material is present, and also hydrostatically tested for all FDC's on any type of standpipe system. Hydrostatic testing shall also be conducted in accordance with NFPA 25 requirements for the different types of standpipe systems.

2. For any manual (dry or wet) standpipe system not having an automatic water supply capable of flowing water through the standpipe, the tester shall connect hose from a fire hydrant or portable pumping system (as approved by the Fire Code Official) to each FDC, and flow water through the standpipe system to the roof outlet to verify that each inlet connection functions properly. Confirm that there are no open hose valves prior to introducing water into a dry standpipe. There is no required pressure criteria at the outlet. Verify that check valves function properly and that there are no closed control valves on the system.

3. Any pressure relief, reducing, or control valves shall be tested in accordance with the requirements of NFPA 25. All hose valves shall be exercised.

4. If the FDC is not already provided with approved caps, the contractor shall install such caps for all FDC's as required by the Fire Code Official.

5. Upon successful completion of standpipe test, place a blue tag (as per Texas Administrative Code, Fire Sprinkler Rules for Inspection, Test and Maintenance Service (ITM) Tag) at the bottom of each standpipe riser in the building. The tag shall be check-marked as "fifth year" for type of ITM, and the note on the back of the tag shall read "5 year standpipe test" at a minimum.

6. The procedures required by Texas Administrative Code Fire Sprinkler Rules with regard to yellow tags and red tags or any deficiencies noted during the testing, including the required notification of the local authority having jurisdiction (Fire Code Official) shall be followed.

7. Additionally, records of the testing shall be maintained by the owner and contractor, if applicable, as required by the State Rules mentioned above and NFPA 25.

8. Standpipe system tests where water will be flowed external to the building shall not be conducted during freezing conditions or during the day prior to expected nighttime freezing conditions.

9. Contact the Fire Code Official for requests to remove existing fire hose from class II and III standpipe systems where employees are not trained in the utilization of this firefighting equipment. All standpipe hose valves must remain in place and be provided with an approved cap and

chain when approval is given to remove hose by the Fire Code Official.

Section 901.7 Fire areas, shall be deleted in its entirety.

Section 901.8 Pump and riser room size shall be amended to add the following:

901.8.1 Pump and riser room. When located on the ground level, the fire pump or sprinkler riser room shall be located at an exterior wall and provided with an exterior Fire Department access door that is not less than three (3) feet in width and six feet, eight inches (6'8") in height, regardless of any interior doors that are provided. A key box shall be provided at this door, as required by the Fire Code Official. The exterior door shall be marked "FIRE RISER ROOM" or "FIRE PUMP ROOM."

Exception: When it is necessary to locate a fire sprinkler riser room on other levels, the corridor leading to the fire sprinkler riser room access from the exterior of the building shall be provided with a minimum one hour fire resistance, or as approved by the Building Official. Access keys shall be provided in the key box as required by the Fire Code Official.

Section 903.1.1 Alternative protection shall be amended to read as follows:

903.1.1 Alternative protection. Alternative automatic sprinkler systems complying with section 904 shall be permitted in addition to automatic sprinkler protection where recognized by the applicable standard, or as approved by the Fire Code Official.

Section 903.1 General shall be amended by adding a new section 903.1.2 to read as follows:

903.1.2 Residential systems. Unless specifically allowed by this Code or the International Fire Code, residential sprinkler systems installed in accordance with NFPA 13D or NFPA 13R shall not be recognized for the purpose of exceptions or

reduction (commonly referred to as "trade-offs") permitted by other provisions of this Code.

Section 903.2 Where required shall be amended to read as follows:

903.2 Where required. Approved automatic sprinkler systems in new buildings and structures shall be provided in the locations described in section 903.2.1 thru 903.2.12 of the Building Code. Automatic sprinklers shall not be installed in elevator machine rooms, elevator machine spaces, and elevator hoistways, other than pits, where such sprinklers would not necessitate shunt trip requirements under any circumstances. Storage shall not be allowed within the elevator machine room. Signage shall be provided at the entry doors to the elevator machine room indicating "ELEVATOR MACHINERY - NO STORAGE ALLOWED."

Section 903.2 Where required shall be amended to delete the exception.

Section 903.2.1.1, Group A-1, shall be amended to change the condition to read as follows:

1. The fire area exceeds 5,000 square feet.

Section 903.2.1.3, Group A-3, shall be amended to change the condition to read as follows:

1. The fire area exceeds 5,000 square feet.

Section 903.2.1.4, Group A-4, shall be amended to change the condition to read as follows:

1. The fire area exceeds 5,000 square feet.

Section 903.2.3, Group E, shall be amended to change the conditions to read as follows:

1. The fire area exceeds 5,000 square feet;
2. Where a group E fire area is located below the lowest level of exit discharge serving that portion of the building; or

3. Where a group E fire area is located more than two stories above grade plane.

Section 903.2.4, Group F-1, shall be amended to change the conditions to read as follows:

1. The fire area exceeds 5,000 square feet;
2. The fire area is located more than two stories above grade plane; or
3. A group F-1 occupancy used for the manufacture of upholstered furniture or mattresses exceeds 2,500 square feet (232 sq meters).

Section 903.2.7, Group M, shall be amended to change the condition to read as follows:

1. The fire area exceeds 5,000 square feet.

Section 903.2.7 Group M shall be further amended by deleting exceptions 3 and 4 in their entirety.

Section 903.2.8.1, Group R, shall be amended by adding an exception to read as follows:

Exception: Group R-3 single-family residences that are less than 5,000 square feet shall not be required to be sprinkled.

Section 903.2.8 Group R shall be amended by adding new sections 903.2.8.5 and 903.2.8.6 to read as follows:

903.2.8.5 Mixed use occupancies. Where buildings are of mixed use, residential portions of the building shall be protected with residential or quick response sprinklers in accordance with NFPA 13. Other portions of such buildings including attic spaces shall be protected in accordance with NFPA 13. NFPA 13R systems shall not be allowed in buildings where portions of mixed use contain residential occupancies. Firewalls and fire separations shall not define separate buildings.

903.2.8.6 Existing R-1 and R-2 occupancies. In R-1 and R-2 occupancies where a fire has occurred and displaces occupants in 50-percent or more of the buildings, the affected building shall be fire sprinkled prior to reoccupancy of the building.

Section 903.2.9, Group S-1 shall be amended to change the conditions to read as follows:

1. The fire area exceeds 5,000 square feet;
2. The fire area is located more than two stories above grade plane;
3. The S-1 occupancy is used for the storage of upholstered furniture or mattresses exceeds 2,500 square feet (232 sq. meters).
4. The fire area used for the storage of commercial trucks or buses exceeds 5,000 square feet.

Section 903.2.9.1, Repair garages, shall be amended to change the conditions to read as follows:

1. The fire area of buildings having two or more stories above grade that exceeds 3,500 square feet;
2. The fire area in a one story building exceeding 5,000 square feet; or
3. The fire area used for the repair of commercial trucks or buses exceeding 2,500 square feet.
4. Buildings with repair garages servicing vehicles parked in basements.

Section 903.2.9.2 Bulk storage of tires shall be amended to read as follows:

903.2.9.2 Bulk tire/storage of tires. Buildings or structures that contain an area for the storage of tires that exceeds 1,000 square feet shall be equipped throughout with an automatic

sprinkler system in accordance with section 903.3.1.1 of the Building Code.

Section 903.2.9.3 Self-service storage facility, a new section, is added to read as follows:

903.2.9.3 Self-service storage facility. An automatic sprinkler system shall be installed throughout all self-service storage facilities. Exception: One-story self-service storage facilities that have no interior corridors, with a one-hour fire barrier separation wall installed between every storage compartment.

Section 903.2.10, Group S-2 enclosed parking garages, shall be amended to change the conditions to read as follows:

If one of the following conditions exist, the building shall be sprinkled:

1. The fire area of the enclosed parking garage exceeds 5,000 square feet.
2. The enclosed parking garage is located beneath other occupancy groups.

Exception: The enclosed parking garage is located beneath a group R-3 occupancy and the R-3 fire area is less than 5,000 square feet.

Section 903.2.11.3 Buildings 55 feet or more in height shall be amended to read as follows:

903.2.11.3 Buildings 35 feet or more in height. An automatic sprinkler system shall be installed throughout buildings with a floor level, other than penthouses in compliance with section 1510 of the International Building Code that is located 35 feet or more above the lowest level of Fire Department vehicle access, measured to the finished floor.

Exception: Open parking structures in compliance with section 406.5 of the Building Code, having no other occupancies above the subject garage.

Section 903.2.11 Specific buildings areas and hazards shall

be amended by adding new sections 903.2.11.7 thru 903.2.11.9 to read as follows:

903.2.11.7 High-piled combustible storage. For any building with a clear height exceeding 12 feet, see chapter 32 of the Fire Code, as adopted and amended by the Code of Ordinances, to determine if those provisions apply.

903.2.11.8 Spray booths and rooms. New and existing spray booths and spraying rooms shall be protected by an approved automatic fire-extinguishing system.

903.2.11.9 Buildings over 5,000 square feet. An automatic sprinkler system shall be installed throughout all buildings 5,000 square feet and greater and in all buildings that are enlarged to be 5,000 square feet and greater. For the purpose of this provision, firewalls shall not define separate buildings.

Exceptions:

1. Open parking garages in compliance with section 406.3 of the Building Code.
2. When of noncombustible construction, the area of awning extension or freestanding canopies, both sides, and not used for displaying or storage shall not be considered for requiring sprinkler protection for areas greater than 5,000 square feet but less than otherwise required by the Building Code.
3. Except for H and I occupancies, an addition with less than 1,000 square feet may be separated from the existing building without causing either the addition or the existing building to be sprinkled. The separation shall be a 2-hour fire barrier for types II and V construction and a 3-hour fire barrier for all other types of construction.

Section 903.3.1.1.1 Exempt locations is amended to read as

follows:

903.3.1.1.1 Exempt locations. When approved by the Fire Marshal, automatic sprinklers shall not be required in the following rooms or areas where such rooms or areas are protected with an approved automatic fire detection system in accordance with section 907.2 of the Building Code that will respond to visible or invisible particles of combustion. Sprinklers shall not be omitted from any room merely because it is damp, of fire resistance rated construction or contains electrical equipment.

1. Any room where the application of water, or flame and water, constitutes a serious life or fire hazard.
2. Any room or space where sprinklers are considered undesirable because of the nature of the contents, when approved by the Fire Marshal.
3. Generator and transformer rooms, under the direct control of a public utility, separated from the remainder of the building by walls and floor/ceiling or roof/ceiling assemblies having a fire resistance rating of not less than 2 hours.
4. Elevator machine rooms, machinery spaces, and hoistways, other than pits where such sprinklers would not necessitate shunt trip requirements under any circumstances.

Section 903.3.1.2 shall be amended by adding a sentence to the end of the paragraph to read as follows:

Sprinkler systems installed in accordance with 13R shall include sprinkler protection in combustibles attics of buildings 2 or more stories in height.

Section 903.3.1.2 NFPA 13R sprinkler system shall be amended by adding a new sections 903.3.1.2.3 and 903.3.1.2.4 to read as follows:

Section 903.3.1.2.3 Attics and attached garages. Sprinkler protection is required in attic spaces of such buildings two or more stories in height, in accordance with NFPA 13 and or NFPA 13R requirements, and attached garages.

903.3.1.2.4 Small room rule. When fire sprinkler systems are required, the omission of sprinkler protection of bathrooms per section 6.8.2 of NFPA 13R-2002 shall not be allowed.

Section 903.3.1.4 Freeze protection shall be added to read as follows:

903.3.1.4 Freeze protection. Freeze protection systems for automatic fire sprinkler systems shall be in accordance with the requirements of the applicable referenced NFPA standard and this section.

903.3.1.4.1 Attics. Only dry-pipe, preaction, or listed antifreeze automatic fire sprinkler systems shall be allowed to protect attic spaces.

Exception: Wet-pipe fire sprinkler systems shall be allowed to protect nonventilated attic spaces where:

1. The attic sprinklers are supplied by a separate floor control valve assembly to allow ease of draining the attic system without impairing sprinklers throughout the rest of the building; and
2. Adequate heat shall be provided for freeze protection as per the applicable referenced NFPA standard; and
3. The attic space is a part of the building's thermal, or heat, envelope, such that insulation is provided at the roof deck, rather than at the ceiling level.

903.3.1.4.2 Heat trace/insulation. Heat trace/insulation shall only be allowed where approved by the Fire Code Official for small sections of large diameter water-filled pipe.

Section 903.3.5 Water supplies, shall be amended by adding a second paragraph to the end of the section to read as follows:

Water supply as required for such systems shall be provided in conformance with the supply requirements of the respective standards; however, every fire protection system shall be designed with a 10 psi safety factor. Reference section 507.4 for additional design requirements.

Section 903.3.7 Fire Department connections, shall be amended by adding the following sentence to the end of the section:

The location of the Fire Department hose connection shall be approved by the Fire Department and all new and existing Fire Department connections shall be marked on the vertical piping with red reflective paint or tape and on the pavement with blue reflective markers.

Section 903.4 Sprinkler system supervision and alarms, shall be amended by adding a second paragraph after the exceptions to read as follows:

Sprinkler and standpipe system water flow detectors shall be provided for each floor tap to the sprinkler system and shall cause an alarm upon detection of water flow for more than 45 seconds. All control valves in the sprinkler and standpipe system, except for Fire Department hose connection valves, shall be electrically supervised to initiate a supervisory signal at the central station upon tampering.

Section 903.4.2 Alarms shall be amended to add second paragraph to read as follows:

The alarm device required on the exterior of the building shall be a weatherproof horn/strobe notification appliance with a minimum 75 candela strobe rating, installed as close as practicable to the Fire Department connection.

Section 905.2 Installation standard, shall be amended by

adding a sentence to the end of the section to read as follows:

Manual dry standpipe systems shall be supervised with a minimum of 10 psig and a maximum of 40 psig air pressure with a high/low alarm.

Section 905.3.2 Group A, shall be amended by deleting exceptions 1 and 2 in their entirety.

Section 905.3.4 Stages shall be deleted in its entirety.

Section 905.3 Required installations, shall be amended to add section 905.3.9 and exception to read as follows:

905.3.9 Buildings exceeding 10,000 sq. ft. In buildings exceeding 10,000 square feet in area per story and where any portion of the building's interior area is more than 200 feet (60960 mm) of travel, vertically and horizontally, from the nearest point of Fire Department vehicle access, class I automatic wet or manual wet standpipes shall be provided.

Exceptions:

1. Automatic dry and semi-automatic dry standpipes are allowed as provided for in NFPA 14.
2. R-2 occupancies of four stories or less in height having no interior corridors.

Section 905.4 Location of class I standpipe hose connections shall be amended to change item 1, 3, and 5, and add Item 7 to read as follows:

1. In every required exit stairway, a hose connection shall be provided for each story above and below grade plane. Hose connections shall be located at an intermediate landing between stories, unless otherwise approved by the Fire Code Official.
2. {No change.}

3. In every exit passageway, at the entrance from the exit passageway to other areas of a building.

Exception: Where floor areas adjacent to an exit passageway are reachable from an exit stairway hose connection by a... {No change to rest.}

4. {No change.}

5. Where the roof has a slope less than four units vertical in 12 units horizontal (33.3-percent slope), each standpipe shall be provided with a two-way hose connection located to serve the roof or at the highest landing of an exit stairway with stair access to the roof provided in accordance with section 1011.12.

6. {No change.}

7. When required by this chapter, standpipe connections shall be placed adjacent to all required exits to the structure and at two hundred feet (200') intervals along major corridors thereafter, or as otherwise approved by the Fire Code Official.

Section 905.5 Location of class II standpipe hose connections, shall be deleted in its entirety.

Section 905.6 Location of class III standpipe hose connections, shall be deleted in its entirety.

Section 905.9 Valve supervision shall be amended by adding a second paragraph after the exceptions to read as follows:

Sprinkler and standpipe system water flow detectors shall be provided for each floor tap to the sprinkler system and shall cause an alarm upon detection of water flow for more than 45 seconds. All control valves in the sprinkler and standpipe systems, except for Fire Department hose connection valves, shall be electrically supervised to initiate a supervisory signal at the central station upon tampering.

Section 907.1 General shall be amended by adding a new section 907.1.4 to read as follows:

907.1.4 Design standards. All new alarm systems shall be addressable fire detection systems. Alarm systems serving more than 20 smoke detectors shall be analog intelligent addressable fire detection systems.

Exception: Existing systems need not comply unless the total building or remodel or expansion initiated after the effective date of the Building Code, as adopted, exceeds 30-percent of the building.

Section 907.2.1 Group A shall be changed to read as follows:

907.2.1 Group A. A manual fire alarm system that activates the occupant notification system in accordance with section 907.5 shall be installed in group A occupancies having an occupant load of 300 or more persons or more than 100 persons above or below the lowest level of exit discharge. Group A occupancies not separated from one another in accordance with section 707.3.10 of the International Building Code shall be considered as a single occupancy for the purposes of applying this section. Portions of group E occupancies occupied for assembly purposes shall be provided with a fire alarm system as required for the group E occupancy.

Exception: {No change.}

Activation of fire alarm notification appliances shall:

1. Cause illumination of the means of egress with light of not less than 1 footcandle (11 lux) at the walking surface level; and
2. Stop any conflicting or confusing sounds and visual distractions.

Section 907.2.3 Group E shall be amended to read as

follows:

907.2.3 Group E. A manual and automatic fire alarm system that initiates the occupant notification signal utilizing an emergency voice/alarm communication system meeting the requirements of section 907.5.2.2 and installed in accordance with section 907.6 shall be installed in group E educational occupancies. When automatic sprinkler systems or smoke detectors are installed, such systems or detectors shall be connected to the building fire alarm system. An approved smoke detection system shall be installed in group E day care occupancies. Unless separated by a minimum of 100 feet open space, all buildings, whether portable buildings or the main building, will be considered one building for alarm occupant load consideration and interconnection of alarm systems.

Exceptions: {unchanged.}

Section 907.2.3 Group E shall be further amended by adding a new "1.1" to exception 1 to read as follows:

1.1 Residential in-home day-care operations with not more than 12 children may use interconnected single station detectors in all habitable rooms. (For care of more than five children 2-1/2 or less years of age, see section 907.2.6 of the Building Code.)

Section 907.2.6 Group I shall be amended to read as follows:

907.2.6 Group I. A manual fire alarm system that activates the occupant notification system in accordance with section 907.5 shall be installed in group I occupancies. An automatic smoke detection system that activates the occupant notification system in accordance with section 907.5 shall be provided in accordance with sections 907.2.6.1, 907.2.6.2, 907.2.6.3.3 and 907.2.6.4.

Exceptions: {unchanged.}

Section 907.2.6 Group I shall be further amended by adding 907.2.6.4 as follows:

907.2.6.4 Group I-4 occupancies. An approved smoke detection system shall be installed in group I-4 occupancies. Where automatic fire sprinklers are not provided, a full-coverage smoke detection system shall be provided in all group I-4 occupancies.

Section 907.2.12.4 Emergency voice/alarm communication system, shall be amended to read as follows:

907.2.12.4. Emergency voice/alarm communication system. The operation of any automatic fire detector, sprinkler water flow device or manual fire alarm box shall automatically sound an alert tone followed by voice instructions giving approved information and directions on a general or selective basis to the following terminal areas on a minimum of the alarming floor above, and the floor below in accordance with the building's fire safety and evacuation plans required by section 404 of the Fire Code as adopted and amended by the Code of Ordinances.

1. Elevator lobbies.
2. Corridors.
3. Rooms and tenant spaces exceeding 1,000 square feet in area.
4. Dwelling units or sleeping units in group R-2 occupancies.
5. Sleeping units in group R-1 occupancies.
6. Areas of refuge as defined in section 1002 of the Building Code.

Section 907.2.13 High-rise buildings, shall be amended to read as follows:

907.2.13 High-rise buildings. In buildings that have any floor located more than 55 feet above

the lowest level of Fire Department vehicle access, a separate zone by floor shall be provided for all of the following types of alarm-initiating devices where provided:

1. Smoke detectors.
2. Sprinkler water flow devices.
3. Manual fire alarm boxes.
4. Other approved types of automatic fire detection devices or suppression systems.

Section 907.2.13, High-rise buildings. Exception 3 shall be changed to read as follows:

3. Open air portions of buildings with an occupancy in group A-5 in accordance with section 303.1 of the International Building Code; however, this exception does not apply to accessory uses including but not limited to skyboxes, restaurants and similarly enclosed areas.

Section 907.4 Initiation devices, shall be amended by adding a second sentence to the end of the section to read as follows:

Manual alarm actuating devices shall be an approved double-action type.

Section 907.4.2 Manual fire alarm boxes, shall be amended to add section 907.4.2.7 to read as follows:

907.4.2.7 Type. Manual alarm initiating devices shall be an approved double action type.

Section 907.6.1 Wiring shall be amended to read as follows:

907.6.1 Wiring. All fire alarm systems shall be installed in such a manner that a failure of any single initiating device or single open in an initiating circuit conductor will not interfere with the normal operation of other such devices. All initiating circuit conductors shall be class "A" wired with a minimum of six feet separation

between supply and return circuit conductors. IDC - class "A" style D; SLC - class "A" style 6; NAC - class "B" style Y. The IDC from an addressable device used to monitor the status of a suppression system may be wired class B, style B provided the distance from the addressable device is within 10-feet of the suppression system device.

907.6.1.1 Wiring installation. All fire alarm systems shall be installed in such a manner that a failure of any single initiating device or single open in an initiating circuit conductor will not interfere with the normal operation of other such devices. All signaling line circuits (SLC) shall be installed in such a way that a single open will not interfere with the operation of any addressable devices (class A). Outgoing and return SLC conductors shall be installed in accordance with NFPA 72 requirements for class A circuits and shall have a minimum of four feet separation horizontal and one foot vertical between supply and return circuit conductors. The initiating device circuit (IDC) from a signaling line circuit interface device may be wired class B, provided the distance from the interface device to the initiating device is ten feet or less.

Section 907.6.3 Initiation device identification, shall be amended to delete all four exceptions.

Section 907.6.6 Monitoring, shall be amended to add sentence at end of paragraph to read as follows:

See 907.6.3 for the required information transmitted to the supervising station.

Section 909.22 Stairway or ramp pressurization alternative, is added to read as follows:

909.22 Stairway or ramp pressurization alternative. Where the building is equipped throughout with an automatic sprinkler system in accordance with section 903.3.1.1 and the stair pressurization alternative is chosen for compliance with Building Code requirements for a

smokeproof enclosure, interior exit stairways or ramps shall be pressurized to a minimum of 0.10 inches of water (25 Pa) and a maximum of 0.35 inches of water (87 Pa) in the shaft relative to the building measured with all interior exit stairway and ramp doors closed under maximum anticipated conditions of stack effect and wind effect. Such systems shall comply with section 909, including the installation of a separate firefighter's smoke control panel as per section 909.16, and a smoke control permit shall be required from the Fire Department as per section 105.7.

909.22.1 Ventilating equipment. The activation of ventilating equipment for the stair or ramp pressurization system shall be by smoke detectors installed at each floor level at an approved location at the entrance to the smokeproof enclosure. When the closing device for the stairway or ramp shaft and vestibule doors is activated by smoke detection or power failure, mechanical equipment shall activate and operate at the required performance levels. Smoke detectors shall be installed in accordance with section 907.3.

909.22.1.1 Ventilation systems. Smokeproof enclosure ventilation systems shall be independent of other building ventilation systems. The equipment, control wiring, power wiring and ductwork shall comply with one of the following:

1. Equipment, control wiring, power wiring and ductwork shall be located exterior to the building and directly connected to the smokeproof enclosure or connected to the smokeproof enclosure by ductwork enclosed by not less than 2-hour fire barriers constructed in accordance with section 707 of the Building Code or horizontal assemblies constructed in accordance with section 711 of the Building Code, or both.
2. Equipment, control wiring, power wiring and ductwork shall be located within the

smokeproof enclosure with intake or exhaust directly from and to the outside or through ductwork enclosed by not less than 2-hour barriers constructed in accordance with section 707 of the Building Code or horizontal assemblies constructed in accordance with section 711 of the Building Code, or both.

3. Equipment, control wiring, power wiring and ductwork shall be located within the building if separated from the remainder of the building, including other mechanical equipment, by not less than 2-hour fire barriers constructed in accordance with section 707 of the Building Code or horizontal assemblies constructed in accordance with section 711 of the Building Code, or both.

Exceptions:

1. Control wiring and power wiring utilizing a 2-hour rated cable or cable system.
2. Where encased with not less than 2 inches (51 mm) of concrete.
3. Control wiring and power wiring protected by a listed electrical circuit protective systems with a fire-resistance rating of not less than 2 hours.

909.22.1.2 Standby power. Mechanical vestibule and stairway and ramp shaft ventilation systems and automatic fire detection systems shall be provided with standby power in accordance with section 2702 of the Building Code.

909.22.1.3 Acceptance and testing. Before the mechanical equipment is approved, the system shall be tested in the presence of the Fire Code Official to confirm that the system is operating in compliance with these requirements.

Section 910.2 Where required, shall be amended to change exception 2 and 3 to read as follows:

2. Only manual smoke and heat removal shall not be required in areas of buildings equipped with early suppression fast-response (ESFR) sprinklers. Automatic smoke and heat removal is prohibited.

3. Only manual smoke and heat removal shall be required in areas of buildings equipped with control mode special application sprinklers with a response time index of  $50(m^*S)^{1/2}$  or less that are listed to control a fire in stored commodities with 12 or fewer sprinklers. Automatic smoke and heat removal is prohibited.

Section 910.3 Smoke and heat vents, shall be amended to add section 910.3.4 to read as follows:

910.3.4 Vent operation. Smoke and heat vents shall be capable of being operated by approved automatic and manual means. Automatic operation of smoke and heat vents shall conform to the provisions of sections 910.3.2.1 through 910.3.2.3.

910.3.4.1 Sprinklered buildings. Where installed in buildings equipped with an approved automatic sprinkler system, smoke and heat vents shall be designed to operate automatically. The automatic operating mechanism of the smoke and heat vents shall operate at a temperature rating at least 100 degrees F (approximately 38 degrees Celsius) greater than the temperature rating of the sprinklers installed.

Exception: Manual only system per 910.2.

910.3.4.2 Nonsprinklered buildings. Where installed in buildings not equipped with an approved automatic sprinkler system, smoke and heat vents shall operate automatically by actuation of a heat-responsive device rated at between 100°F (56°C) and 220°F (122°C) above ambient.

Exception: Listed gravity-operated drop out

vents.

Section 910.4.3.1 Makeup air shall be changed to read as follows:

910.4.3.1 Makeup air. Makeup air openings shall be provided within 6 feet (1829 mm) of the floor level. Operation of makeup air openings shall be automatic. The minimum gross area of makeup air inlets shall be 8 square feet per 1,000 cubic feet per minute (0.74 m<sup>2</sup> per 0.4719 m<sup>3</sup>/s) of smoke exhaust.

Section 910.4.4 Activation shall be changed to read as follows:

910.4.4 Activation. The mechanical smoke removal system shall be activated automatically by the automatic sprinkler system or by an approved fire detection system. Individual manual controls shall also be provided.

Exception: Manual only systems per section 910.2.

Section 1004.1.2 Areas without fixed seating shall be amended by deleting the exception in its entirety.

Section 1006.2.2.6 Electrical rooms, shall be added follows:

1006.2.2.6 Electrical rooms. For electrical rooms, special exiting requirements may apply. Reference the Electrical Code as adopted.

Section 1009.1 Accessible means of egress required, shall be amended by adding a new exception to read as follows:

4. Buildings regulated under state law and built in accordance with state registered plans, including any variances or waivers granted by the state, shall be deemed to be in compliance with the requirements of section 1007 of the Building Code.

Section 1010.1.9.4 Bolt locks is amended by amending exceptions 3 and 4 as follows:

Exceptions:

3. Where a pair of doors serves an occupant load of less than 50 persons in a group B, F, M or S occupancy. {Remainder unchanged}

4. Where a pair of doors serves a group A, B, F, M or S occupancy {Remainder unchanged}

Section 1015.8 Window openings shall be amended to revise text as follows:

First paragraph unchanged

1. Operable windows where the top of the sill of the opening is located more than 55 feet (16 764 mm) above the finished grade or other surface below and that are provided with window fall prevention devices that comply with ASTM F 2006.

Balance unchanged

Section 1020.1 Construction shall be amended by adding new exceptions 6 and 7 to read as follows:

6. Corridor walls and ceilings need not be fire-resistive construction within a single-tenant space in other than A, E or H occupancies when the tenant space is equipped with an automatic smoke detector system installed within the corridor in accordance with the smoke detector's listing. The actuation of any detector shall activate alarms audible in all areas served by the corridor. The smoke detection system shall be connected to the building's fire alarm system where such a system is provided.

7. In group B occupancies, corridor walls and ceilings need not be of fire resistive construction within a single tenant space when the space is equipped with an approved automatic smoke detection system within the corridor. The actuation of any detector shall activate self-annunciating alarms

audible in all areas served by the corridor. Smoke detectors shall be connected to an approved automatic fire alarm system where such system is provided.

Section 1025.1 General, shall be amended to read as follows:

1025.1 General. Approved luminous egress path markings delineating the exit path shall be provided in high-rise buildings of groups A, B, E, I, M and R-1 occupancies in accordance with sections 1025.1 thru 1025.5 of the Building Code.

Exceptions:

1. Luminous egress path markings shall not be required on the level of exit discharge in lobbies that serve as part of the exit path in accordance with section 1027.1, exception 1.
2. Luminous egress path markings shall not be required in areas of open parking garages that serve as part of the exit path in accordance with section 1027.1, exception.

Section 1029.1.1.1 Spaces under grandstands and bleachers shall be deleted in its entirety.

Section 1101.1 Scope shall be amended to add exception to read as follows:

Exception: Components of projects regulated by and registered with Architectural Barriers Division of Texas Department of Licensing and Regulation shall be deemed to be in compliance with the requirements of this chapter.

Section 1101.2 Design shall be amended to add an exception to read as follows:

Exception: Buildings regulated under state law and built in accordance with state registered plans, including any variances or waivers granted by the state, shall be deemed to be in compliance with the requirements of this chapter of the

Building Code.

Section 1203.1 General shall be amended to read as follows:

1203.1 General. Buildings shall be provided with natural ventilation in accordance with section 1203.4, or mechanical ventilation in accordance with the International Mechanical Code.

Where air infiltration rate in a dwelling unit is 5 air changes or less per hour when tested with a blower door at a pressure 0.2 inch w.c. (50 Pa) in accordance with section 402.4.1.2 of the International Energy Conservation Code, the dwelling unit shall be ventilated by mechanical means in accordance with section 403 of the International Mechanical Code.

Section 1405.3 Vapor retarders, is amended to add the following sentences to the section:

In all framed walls, floors and roofs/ceilings comprising elements of the building thermal envelope, a vapor retarder, when installed, shall be installed in a manner so as to not trap moisture. Vapor retarders shall be tested in accordance with ASTM E 96.

Table 1505.1 Minimum roof covering classification for types of construction shall be amended by replacing footnote "b" adding "d" as follows:

b. Nonclassified roof coverings shall be permitted on buildings of U occupancies having not more than 120 square feet of projected roof area. When exceeding 120 square feet of projected roof area, buildings of U occupancies may use nonrated, noncombustible roof coverings.

d. All individual replacement shingles or shakes shall comply with the rating required by this table.

Section 1511.1 General shall be amended to read as follows:

1511.1 General. Materials and methods of applications used for recovering or replacing an existing roof covering shall comply with the requirements of chapter 15. All individual replacement shingles or shakes shall be in compliance with the rating required by table 1505.1.

{text of exception unchanged}

Section 1612 Flood load shall be deleted in its entirety.

Section 1704.2, Special inspections and tests shall be amended to read as follows:

1704.2 Special inspections and tests. Where application is made to the Building Official for construction as specified in section 105, the owner or the owner's authorized agent, or the registered design professional in responsible charge, other than the contractor, shall employ one or more approved agencies to provide special inspections and tests during construction on the types of work listed under section 1705 and identify the approved agencies to the Building Official. The special inspector shall not be employed by the contractor. These special inspections and tests are in addition to the inspections identified by the Building Official that are identified in section 110.

Section 1704.2.1 Special inspector qualifications shall be amended to read as follows:

1704.2.1 Special inspector qualifications. Prior to the start of construction and or upon request, the approved agencies shall provide written documentation to the registered design professional in responsible charge and the Building Official demonstrating the competence and relevant experience or training of the special inspectors who will perform the special inspections and tests during construction.  
[Remainder unchanged]

Section 1704.2.4 Report requirement shall be amended to read as follows:

1704.2.4 Report requirement. Approved agencies shall keep records of special inspections and tests. The approved agency shall submit reports of special inspections and tests to the Building Official upon request, and to the registered design professional in responsible charge. Individual inspection reports shall indicate that work inspected or tested was or was not completed in conformance to approved construction documents. {Remainder unchanged}

Section 1704.2.5.2 Fabricator approval shall be amended to read as follows:

1704.2.5.1 Fabricator approval. Special inspections during fabrications required by section 1704 are not required where the work is done on the premises of a fabricator registered and approved to perform such work without special inspection. Approval shall be based upon review of the fabricator's written procedural and quality control manuals and periodic auditing of fabrication practices by an approved agency, or a fabricator that is enrolled in a nationally accepted inspections program. At completion of fabrication, the acceptable or approved fabricator shall submit a certificate of compliance to the owner or the owner's authorized agent or the registered design professional in responsible charge stating that the work was performed in accordance with the approved construction documents. The certificate of compliance shall also be made available to the Building Official upon request.

Section 1801.2 Design basis shall be amended by adding new sections 1801.2.2 and 1801.2.3 to read as follows:

1801.2.2 Foundation repairs. All foundation repairs that exceed \$2,000.00 shall be designed and monitored by an engineer licensed in the state.

1801.2.3 Foundations over 1,000 square feet. All commercial foundations supporting an area of 1,000 square feet or more shall be designed by an

engineer licensed in the state.

Section 1803.1 General is amended by adding the following sentences to the end of the section to read as follows:

The requirements for protection of adjacent property and the depth to which the protection is required shall be defined by prevailing law. Lateral support of adjoining property is of a civil nature between adjoining property owners.

Section 1804.4 Site grading is amended to add the following:

Grading and drainage shall be designed and maintained in conformance with the City of Garland Technical Standards Manual.

Section 2308.2 Limitations shall be amended by adding a new section 2308.2.7 to read as follows:

2308.2.7 Application to engineered design. When accepted by the Building Official, any portion of this section is permitted to apply to buildings that are otherwise outside the limitations of this section provided that:

1. The resulting design will comply with the requirements specified in chapter 16 of the Building Code;
2. The load limitations of various elements of this section are not exceeded; and
3. The portions of this section which will apply are identified by an engineer in the construction documents.

Section 2902.1 Minimum number of fixtures shall be amended to read as follows:

2902.1 Minimum number of fixtures. Plumbing fixtures shall be provided in the minimum number as shown in table 2902.1 based on the actual use of the building or space. Uses not shown in table 2902.1 shall be considered individually by the Building Official. The number of occupants shall

be determined by this Code. In other than E occupancies, the minimum number of fixtures in table 2902.1 may be lowered, if requested in writing, by the applicant stating reasons for a reduced number and approved by the Building Official.

Plumbing fixtures shall be provided for the type of occupancy and in the minimum number as follows:

1. Assembly occupancies: At least one drinking fountain shall be provided at each floor level in an approved location. Exception: a drinking fountain need not be provided in a drinking or dining establishment.

2. Groups A, B, F, H, I, M and S occupancies: Buildings or portions thereof where persons are employed shall be provided with at least one water closet for each sex except as provided for in section 2902.2 of the Building Code.

3. Group E occupancies: Shall be provided with fixtures as shown in table 2902.1 of the Building Code.

4. Group R occupancies: Shall be provided with fixtures as shown in table 2902.1 of the Building Code.

Table 2902.1 Minimum number of required plumbing fixtures shall be amended to add footnote "f" to read as follows:

f. Drinking fountains are not required in M occupancies with an occupant load of 100 or less, B occupancies with an occupant load of 25 or less, and for dining and/or drinking establishments.

Section 2902.1.3 Additional fixtures for food preparation facilities shall be added to read as follows:

2902.1.3 Additional fixtures for food preparation

facilities. In addition to the fixtures required in this chapter, all food service facilities shall be provided with additional fixtures set out in this section.

2902.1.3.1 Handwashing lavatory. At least one handwashing lavatory shall be provided for use by employees that is accessible from food preparation, food dispensing and ware washing areas. Additional handwashing lavatories may be required based on convenience of use by employees.

2902.1.3.2 Service sink. In new or remodeled food service establishments, at least one service sink or one floor sink shall be provided so that it is conveniently located for the cleaning of mops or similar wet floor cleaning tool and for the disposal of mop water and similar liquid waste. The location of the service sink(s) and/or mop sink(s) shall be approved by the jurisdiction's Health Department.

Section 3002.1 Hoistway enclosure protection shall be amended to add exceptions to read as follows:

Exceptions:

1. Elevators wholly located within atriums complying with section 404 shall not require hoistway enclosure protection.
2. Elevators in open or enclosed parking garages that serve only the parking garage, and complying with sections 406.5 and 406.6, respectively, shall not require hoistway enclosure protection.

Section 3005.4 Machine rooms, control rooms, machinery spaces and control spaces, shall be amended by altering the first sentence in this section to read as follows:

Section 3005.4 Machine rooms, control rooms, machinery spaces and control spaces. Elevator machine rooms, control rooms, control spaces and machinery spaces shall be enclosed with fire barriers constructed in accordance with section

707 or horizontal assemblies constructed in accordance with section 711, or both.

[Remainder unchanged]

Section 3005.7 Fire protection in machine rooms, control rooms, machinery spaces and control spaces shall be added to read as follows:

3005.7 Fire Protection in machine rooms, control rooms, machinery spaces and control spaces.

3005.7.1 Automatic sprinkler system. The building shall be equipped throughout with an automatic sprinkler system in accordance with section 903.3.1.1, except as otherwise permitted by section 903.3.1.1.1 and as prohibited by section 3005.7.2.1.

3005.7.2 Prohibited locations. Automatic sprinklers shall not be installed in machine rooms, elevator machinery spaces, control rooms, control spaces and elevator hoistways.

3005.7.3 Sprinkler system monitoring. The sprinkler system shall have a sprinkler control valve supervisory switch and water-flow initiating device provided for each floor that is monitored by the building's fire alarm system.

3005.7.4 Water protection. An approved method to prevent water from infiltrating into the hoistway enclosure from the operation of the automatic sprinkler system outside the elevator lobby shall be provided.

3005.7.5 Shunt trip. Means for elevator shutdown in accordance with section 3005.5 shall not be installed.

Section 3005.8 Storage, shall be added to read as follows:

3005.8 Storage. Storage shall not be allowed within the elevator machine room, control room, machinery spaces and or control spaces. Provide approved signage at each entry to the above listed locations stating: "no storage allowed."

Section 3006.2, Hoistway opening protection required, condition #5 shall be amended to read as follows:

5. The building is a high rise and the elevator hoistway is more than 55 feet (16,764 mm) in height. The height of the hoistway shall be measured from the lowest floor at or above grade to the highest floors served by the hoistway.

Section 3106 Marquees shall be deleted in its entirety.

Section 3107 Signs shall be deleted in its entirety.

Section 3307.1 Protection required shall be amended to read as follows:

3307.1 Protection of adjoining property. The requirements for protection of adjacent property and the depth to which the protection is required shall be defined by prevailing law. Lateral support of adjoining property is of a civil nature between adjoining property owners."

## **Section 2**

That Section 30.05, "Exterior materials", of Chapter 30, "Building Inspection", of the Code of Ordinances of the City of Garland, Texas, is hereby amended to read as follows:

### **"Section 30.05 Exterior materials**

Unpainted materials such as wood, tin, plain concrete block or similar materials shall not be used as exterior wall or roof covering on residential or commercial buildings."

## **Section 3**

That Section 30.40, "Adoption of the National Electrical Code", of Chapter 30, "Building Inspection", of the Code of Ordinances of the City of Garland, Texas, is amended to read as follows:

**"Section 30.40 Adoption of the National Electrical Code**

(A) The National Electrical Code, 2014 edition, is hereby adopted by reference. One (1) copy is to remain on file in the City Secretary's office. Unless deleted, amended, expanded or otherwise changed herein, all provisions of this Code shall be fully applicable, binding, and of full force and effect.

(B) These regulations shall be known as the "Electrical Code," may be cited as such, and will be referred to herein as "this Code."

(C) Amendments, modifications and deletion. The following articles of the National Electrical Code adopted by subsection (A) of this section are amended, modified or deleted as follows:

Article 90.1 "Purpose" be amended by adding subsection (D) "conflicting provisions" as follows:

(D) Conflicting provisions. Where, in any specific case, different sections of this Code specify different materials, methods of construction or other requirements, the most restrictive shall govern.

Article 90.2 "Scope" is amended by adding subsection (D) "Alternate materials and methods of construction" as follows:

(D) Alternate materials and methods of construction.

(1) The provisions of this Code are not intended to prevent the use of any material or method of construction not specifically prescribed in this Code, provided any alternate has been approved and its use authorized by the Building Official.

(2) The Building Official may approve any alternate material or method of construction, provided he finds that the proposed design is satisfactory, complies with the provisions of this Code, and that the material, method or work offered is, for

the purpose intended, at least the equivalent of that prescribed in this Code in suitability, strength, effectiveness, fire resistance, durability and safety.

(3) The Building Official shall require any person seeking approval of an alternate material or method of construction to provide sufficient evidence or proof that the alternate material or method of construction satisfies the requirement of subsection (B) above. Provided, however, that the approval or authorization of any alternate shall not be construed as warranting or representing the safety of any approved alternate.

Article 90.4 "Enforcement" shall be amended by adding subsection (A) "modifications" as follows:

(A) Modifications. The electrical regulations of this article may be modified or waived in writing by the Building Official pursuant to section 90.4 of the Electrical Code provided he shall first find that:

(1) A special individual reason makes the strict letter of this Code impractical;

(2) The modification is in conformity with the intent and purpose of this Code; and

(3) That such modification does not lessen health, life and fire safety requirements. Any waiver or modification shall be obtained from the Building Official prior to starting the work, and a copy of the modification or waiver shall be filed in the office of the Building Official by the applicant.

Article 90.4 "Enforcement" shall be amended by adding subsection (B) "powers and duties of the Building Official" as follows:

(B) Powers and duties of Building Official.

(1) General. The Building Official is hereby

authorized to enforce all the provisions of this Code, which authority includes, but is not limited to the authority to issue a citation to any person who violates any of its provisions. He shall cause a record to be kept of all permits issued and inspections made.

(2) Deputies. In accordance with prescribed procedures and with the approval of the appointing authority, the Building Official may appoint technical officers and inspectors and other employees as shall be authorized from time to time. Such employees shall have powers as delegated by the Building Official.

(3) Conflict of interest. It shall be unlawful for an employee of the Building Inspection Department to engage in the business of selling, installing, or maintenance of electrical fixtures, devices, equipment or materials, and they shall have no financial interest in any concern engaged in such business at any time while employed by the City.

(4) Right of entry.

(a) Whenever necessary to make an inspection to enforce any of the provisions of this Code, or whenever the Building Official or his authorized representative has reasonable cause to believe that there exists in any building or upon any premises any condition or violation which makes such building or premises unsafe, dangerous or hazardous, the Building Official or his authorized representative, in accordance with applicable law, may enter such building or premises at all reasonable times to inspect the same or to perform any duty imposed upon the Building Official by such Codes, provided that if such building or premises be occupied, he shall first

present proper credentials and request entry. If such building or premises is unoccupied, he shall first make a reasonable effort to locate the owner or other persons having charge or control of the building or premises and request entry. If entry be refused, the Building Official or his authorized representative shall have recourse to every remedy provided by law to secure entry.

(b) When the Building Official or his authorized representative shall have first obtained a proper inspection warrant or other remedy provided by law to secure entry, no owner or occupant or any other persons having charge, care or control of any building or premises shall fail or neglect, after proper request is made as herein provided, to promptly permit entry therein by the Building Official or his authorized representative for the purpose of inspection and examination pursuant to this Code.

(5) Notice.

(a) When any order or notice is issued pursuant to the provisions of this Code to any person who cannot be found after a reasonable search, such order or notice may be served by posting it in a conspicuous place upon the premises occupied by him or upon the premises where the defects are alleged to exist. Such posting of the notice shall be considered equivalent to personal service of such order or notice. An order sent by mail in a sealed envelope with postage prepaid and directed to the address of the electrical contractor, owner, lessee, or occupant of the premises shall be equivalent to personal service of such order.

(b) Inspectors are hereby empowered to attach to the nearest electrical cabinet or equipment feeding defective or hazardous wiring, any official notice or seal to prevent use of electricity in that area, and it shall be unlawful for any other person to place or attach such seal, or to break, change, destroy, tear, mutilate, cover or otherwise deface or injure any such official notice or seal posted by an inspector.

(6) Stop orders. Whenever any work is being done contrary to the provisions of this Code, the Building Official may order the work stopped by notice in writing served on any persons engaged in the doing or causing such work to be done, and any such persons shall forthwith stop such work until authorized by the Building Official to proceed with the work.

(7) Authority to disconnect utilities in emergencies. The Building Official or his authorized representative shall have the authority to disconnect any electric power or energy service supplied to the building, structure or building service equipment therein regulated by this Code in case of emergency where necessary to eliminate an immediate hazard to life or property. The Building Official shall whenever possible notify the serving utility, the owner and occupant of the building, structure or building service equipment, in writing, of such disconnection immediately thereafter.

(8) Authority to condemn electrical system and equipment.

(a) Whenever the Building Official ascertains that any electrical system or equipment regulated in this Code has become hazardous to life, health or property, he may order in writing that such electrical system or equipment

either be removed or restored to a safe condition, whichever is appropriate. The written notice itself shall fix a time limit for compliance with such order. No person shall use or maintain defective electrical system or equipment after receiving such notice.

(b) When such equipment or installation is to be disconnected, a written notice of such disconnection and causes therefor shall be given within 24 hours of the order to disconnect to the serving utility, the owner and occupant of such building, structure or premises.

(c) When any electrical system or equipment is maintained in violation of this Code and in violation of any notice issued pursuant to the provisions of this section, the Building Official shall institute any appropriate action to prevent, restrain, correct or abate the violation.

(9) Connection after order to disconnect. No person shall make connections from any energy or power supply nor supply power to any electrical system or equipment which has been disconnected or ordered to be disconnected by the Building Official or the use of which has been ordered to be discontinued by the Building Official until the Building Official authorizes the reconnection and use of such electrical system or equipment.

(10) Liability.

(a) The Building Official, or his authorized representative charged with the enforcement of this Code, acting in good faith and without malice in the discharge of his duties, shall not thereby render himself personally

liable for any damage that may accrue to persons or property as a result of any act or by reason of any act or omission in the discharge of his duties. Any suit brought against the Building Official or employee because of such act or omission performed by him in the enforcement of any provision of this Code shall be defended by legal counsel provided by this jurisdiction until final termination of such proceedings.

(b) This Code shall not be construed to relieve from or lessen the responsibility of any person owning, operating or controlling any building, structure or building service equipment therein for any damages to persons or property caused by defects, nor shall the Code Enforcement Agency or its parent jurisdiction be held as assuming any such liability by reason of the inspections authorized by the Code or approvals issued under this Code.

(11) Cooperation of other officials and officers. The Building Official may request, and shall receive so far as is required in the discharge of his duties, the assistance and cooperation of other officials of this jurisdiction.

Article 110.3(B) "Installation and use" shall be amended by adding subsection (A) "unsafe electrical systems or equipment" as follows:

(A) Unsafe electrical systems or equipment.

(1) All electrical systems or equipment regulated by this Code which constitute a fire hazard or are otherwise dangerous to human life are, for the purpose of this section, unsafe. Any use of electrical systems or equipment regulated by this Code constituting a hazard to safety, health or public welfare by reason of inadequate

maintenance, dilapidation, obsolescence, fire hazard, disaster, damage or abandonment is, for the purpose of this section, an unsafe use.

(2) All such unsafe electrical systems or equipment are hereby declared to be public nuisances and shall be abated by repair, rehabilitation, demolition or removal in accordance with the procedures set forth in [article II of chapter 30](#) or [article I of chapter 32](#) of the Code of Ordinances of the City of Garland, as applicable, or such alternate procedure as may be adopted by this jurisdiction. As an alternative, the Building Official or other employee or official of the City as designated by the governing body may institute any other appropriate action to prevent, restrain, correct or abate the violation.

Article 90.4 "Enforcement" shall be amended by adding subsection (C) "violations" as follows:

(C) Violations. It shall be unlawful for any person, firm or corporation to erect, construct, enlarge, alter, repair, move, improve, remove, convert or demolish, equip, use or maintain any electrical system or equipment or cause or permit the same to be done in violation of this Code. Any violation of this Code is a misdemeanor and shall be punishable as provided by [section 10.05](#) of the Code of Ordinances of the City of Garland. The issuance or granting of a permit or approval of plans and specifications or the completion or approval of an inspection shall not be deemed or construed to be a permit for, or an approval of, any violation of any of the provisions of this Code. No permit presuming to give authority to violate or cancel the provisions of this Code shall be valid, except insofar as the work or use which is authorized is lawful.

Article 90 "Introduction" be amended by adding article 90.10 "electrical licensing and registration" as follows:

90.10 Electrical licensing and registration.

(A) License required.

(1) Every person engaged in the construction, installation, maintenance, extension, repairing or replacement of electrical wiring, apparatus or equipment that performs work prescribed by a person, firm or corporation registered under the provisions of this article must have on their person proof of an electrical license, electrical apprentice or electrical sign apprentice license issued by the Texas Department of Licensing and Regulation.

(2) It shall be unlawful for a person, firm or corporation registered with the City of Garland to engage in any phase of the electrical business or perform any work in the electrical trade other than such business or work authorized by the registration, the class of license or the permit held by that person, provided, however, that an apprentice electrician or apprentice sign electrician may perform electrical work prescribed for him when issued an Electrical Apprentice License by the Texas Department of Licensing and Regulation enabling said holder to do such work, and then only when in the presence of and being supervised by an electrician with the proper electrical license issued by the Texas Department of Licensing and Regulation.

(3) A properly licensed electrician is required to be on the same platted lot as the work which is taking place and for the apprentice to know how to quickly locate the properly licensed electrician. All electricians on the jobsite must have a valid TDLR issued electricians apprentice registration or wireman, journeyman, or master electricians license.

(4) A journeyman, or master electrician must

be present on the jobsite at all times when electrical work is being performed.

(B) Registration required.

(1) Any person providing services as an electrical contractor in the City must register with the Building Inspection Department as a contractor. To register with the City as a contractor, application shall be made in writing on forms furnished for that purpose and filed with the Building Official. The application shall show the contractor's name, local address and telephone number, a copy of the applicant's state electrical contractor's license, and such other information as may reasonably be required to properly identify the contractor. Such application shall be accompanied by the fee prescribed in the fee schedule located in section 30.301 of this Code.

(2) Except as provided in subsection (3), all provisions of the Texas Electrical Safety and Licensing Act, found in the State Occupations Code, title 8, chapter 1305 and the Administrative Rules of the State Department of Licensing and Regulation, 16 Texas Administrative Code, chapter 73 shall be in full force within the City.

(3) Any electrical license or registration issued by the City which has not expired by the adoption date of the ordinance codified in this article shall remain valid and in full effect until the expiration date of said license. Upon the expiration date of said license, the City will not renew or honor the rights previously granted by the license. When all such licenses are expired, the electrical licensing program of the City shall cease.

Article 90 "Introduction" is amended by adding article 90.11 "permits" as follows:

90.11 Permits.

(A) Permits required. Except as specified in subsection (C) of this section, no electrical system regulated by this Code shall be installed, altered, repaired, replaced or remodeled unless a separate electrical permit for each building or structure has first been obtained from the Building Official, or without first submitting a subcontractor's affidavit form for work authorized under a combined building permit.

(B) Permit nontransferable. It shall be unlawful for any person to lend, rent, or transfer an electrical permit or subcontractor's affidavit, or permit a person without proper license or registration to do the work, or for any person to make use of any such permit or affidavit which is not actually his own, and any such permit obtained or affidavit submitted under these conditions shall be null and void.

(C) Exempt work. An electrical permit shall not be required for the following:

(1) Portable motors or other portable appliances energized by means of a cord or cable having an attachment plug end to be connected to an approved receptacle when that cord or cable is permitted by this Code.

(2) Repair or replacement of fixed motors, transformers or fixed approved appliances of the same type and rating in the same location.

(3) Temporary decorative lighting.

(4) Repair or replacement of current-carrying parts of any switch, contactor or control device.

(5) Reinstallation of attachment plug receptacles, but not the outlets therefor.

(6) Repair or replacement of any overcurrent

device of the required capacity in the same location.

(7) Repair or replacement of electrodes or transformers of the same size and capacity for signs or gas tube systems.

(8) Taping joints.

(9) Removal of electrical wiring.

(10) Temporary wiring for experimental purposes in suitable commercial and industrial experimental laboratories.

(11) The wiring for temporary theater, motion picture or television stage sets.

(12) Electrical wiring, devices, appliances, apparatus or equipment operating at less than 25 volts and not capable of supplying more than 50 watts of energy.

(13) Low-energy power, control and signal circuits of classes II and III as defined in this Code.

(14) A permit shall not be required for the installation, alteration or repair of electrical wiring, apparatus or equipment or the generation, transmission, distribution or metering of electrical energy or in the operation of signals or the transmission of intelligence by a public or private utility in the exercise of its function as a serving utility.

Exemption from the permit requirements of this Code shall not be deemed to grant authorization for any work to be done in violation of the provisions of this Code or any other laws or ordinances.

(D) Application. To obtain a permit, the applicant shall first file an application therefor in writing on a form furnished by the Code Enforcement Agency for that purpose. Every such application shall:

(1) Identify and describe the work to be covered by the permit for which application is made.

(2) Describe the land on which the proposed work is to be done by legal description, street address or similar description that will readily identify and definitely locate the proposed building or work.

(3) Indicate the use or occupancy for which the proposed work is intended.

(4) Be accompanied by plans, diagrams, computations and specifications and other data as required in subsection (B) of this section.

(5) Be signed by permittee, or his authorized agent.

(6) Give such other data and information as may be required by the Building Official.

(E) Plans and specifications. With each application for a permit, and where required by the Building Official for enforcement of any provision of this Code, plans, specifications and calculations shall be submitted in the quantity deemed necessary by the Building Official. When deemed necessary by the Building Official to ensure Code compliance, the Building Official may require plans and specifications to be prepared and designed by an engineer licensed by the state. All drawings, specifications and accompanying data involved with the practice of engineering, such as structural, mechanical, plumbing, electrical, heating and cooling, energy, fire, life and safety systems, shall comply with state and local laws governing the practice of engineering as required by the Texas Engineering Practice Act, chapter 1001 of the Texas Occupations Code.

(F) Information on plans and specifications. Plans and specifications shall be drawn to scale

upon substantial paper and shall be of sufficient clarity to indicate the location, nature and extent of the work proposed and show in detail that it will conform to the provisions of this Code and all relevant laws, ordinances, rules and regulations.

(G) Issuance.

(1) The applications, plans and specifications, and other data, filed by an applicant for permit may be reviewed by other departments of the City to determine compliance with any applicable laws under their jurisdiction. If the work described in an application for a permit and the plans, specifications and other data filed therewith conforms to the requirements of this Code and other pertinent laws and ordinances, and the fees prescribed in the fee schedule ([section 30.301](#) of this Code) have been paid, the Building Official may issue a permit therefor to the applicant.

(2) When the Building Official issues the permit where plans are required, he shall endorse in writing or stamp the plans and specifications "APPROVED." Such approved plans and specifications shall not be changed, modified or altered without authorizations from the Building Official, and all work shall be done in accordance with the approved plans.

(3) The Building Official may issue a permit for the construction of part of an electrical system before the entire plans and specifications for the whole system have been submitted or approved, provided adequate information and detailed statements have been filed complying with all pertinent requirements of this Code. The holder of such permit shall proceed at his own risk with assurance that the permit for the entire building, structure or building service will be granted.

(H) Retention of plans. One set of approved plans and specifications shall be returned to the applicant and shall be kept on the site of the building or work at all times during which the work authorized thereby is in progress. One set of approved plans, specifications and computations shall be retained by the Building Official until final approval of the work.

(I) Validity of permit.

(1) The issuance of a permit or approval of plans and specifications shall not be construed to be a permit for, or an approval of, any violation of any of the provisions of this Code, or of any other ordinance of the City, nor shall the issuance of a permit or approval of plans be construed as representing or warranting the safety or lack of defects of any electrical work described therein. No permit presuming to give authority to violate or cancel the provisions of these Codes shall be valid.

(2) The issuance of a permit based upon plans, specifications and other data shall not prevent the Building Official from thereafter requiring the correction of errors in said plans, specifications and other data, or from preventing building operations being carried on thereunder when in violation of these Codes or of any other ordinances of the City.

(J) Expiration. An individual permit issued by the Building Official shall expire by limitation and become null and void on the expiration of one (1) year after its issuance if no progress has been made toward the completion of the project, or upon expiration of the project. (A project shall expire immediately after the first anniversary of the date the first permit application was filed for the project if no progress had been made towards completion of the project.) Once a permit for particular work has expired, a new permit must be applied for and obtained before the work can be commenced. The

permit fee shall be the full amount required for a new permit for such work. The Building Official or his designee shall determine the extent to which the work must comply with any new regulations that were not in effect at the time the original permit was issued.

(K) Suspension or revocation. The Building Official may, in writing, suspend or revoke a permit issued under the provisions of this Code whenever the permit is issued in error or on the basis of incorrect information supplied, or in violation of any ordinance or regulation of the City.

Article 90 "Introduction" is amended by adding article 90.12 "inspections" as follows:

90.12 Inspections.

(A) General. All electrical systems and equipment for which a permit is required by this Code shall be subject to inspection by the Building Official. No portion of any electrical system intended to be concealed shall be concealed until inspected and approved. Neither the Building Official nor the City shall be liable for expense entailed in the removal or replacement of any material necessary to allow inspection. When the installation of an electrical system and equipment is complete, an additional and final inspection shall be made. Electrical systems and equipment regulated by this Code shall not be connected to the energy source until authorized by the Building Official.

(B) Inspection requests.

(1) It shall be the duty of the person doing the work authorized by a permit to notify the Building Official that such work is ready for inspection. The Building Official may require that every request for inspection be filed at least one working day before such inspection is desired. Such request may be in writing, online, or by telephone at the option of the Building

Official.

(2) It shall be the duty of the person requesting inspections required by this Code to provide access to and means for proper inspection of such work.

(C) Operation of electrical equipment. The requirements of this section shall not be construed to prohibit the operation of any electrical system or equipment installed to replace existing equipment. The request for inspection of such equipment must have been filed with the Building Official not more than 48 hours after such replacement work is completed and before any portion of such electrical system is concealed by any permanent portion of the building.

(D) Other inspections. In addition to the called inspections required by this Code, the Building Official may make or require other inspections of any work to ascertain compliance with the provisions of this Code and other laws which are enforced by the Code Enforcement Agency.

(E) Reinspections.

(1) A reinspection fee may be assessed for each inspection or reinspection when such portion of work for which inspection is called is not complete or when required corrections are not made.

(2) This provision is not to be interpreted as requiring reinspection fees the first time a job is rejected for failure to comply with the requirements of this Code, but as controlling the practice of calling for inspections before the job is ready for such inspection or reinspection or when required corrections are not made.

(3) Reinspection fees may be assessed when the approved plans are not readily available to the inspector, for failure to provide access on the date for which inspection is

requested, or for deviating from plans requiring the approval of the Building Official.

(4) The applicant shall pay the reinspection fee prior to requesting a reinspection.

(5) In instances where reinspection fees have been assessed, no additional inspection of the work will be performed until the required fees have been paid.

(6) On the first offense, the inspection is refused, failed and a reinspection fee is assessed. If there are subsequent violations, additional action may be taken ranging from citations to suspension of the City of Garland Electrical Contractors Business Registration.

Article 90 "Introduction" is amended by adding article 90.13 "connection to electric utilities" as follows:

90.13 Connection to electric utilities.

(A) Energy connections. An electrical system or equipment regulated by this Code for which a permit is required shall not be connected to a source of energy or power until approved by the Building Official.

(B) Temporary connections. The Building Official may authorize the temporary connection of the electrical system or equipment to the source of energy or power for the purpose of testing the equipment, or for the use under a temporary certificate of occupancy. The temporary wiring shall not be left energized while unattended.

Article 90 "Introduction" is amended by adding article 90.14 "working hours" as follows:

90.14 Working hours.

(A) Hours established. Any outside work being done adjacent to an occupied residential subdivision or adjacent to an occupied

residential use, including multifamily uses, shall be allowed only between 7:00 a.m. and 8:00 p.m. each day of the week. Any outside work being done adjacent to an occupied residential subdivision or adjacent to an occupied residential use, including multifamily uses, shall be prohibited between 8:00 p.m. and 7:00 a.m. each day of the week.

(B) Other regulations unaffected. This section does not authorize violation of any other legally established regulation, either public or private, regulating noise nuisance to residents.

(C) Exceptions. These regulations do not affect emergency work being done to secure a structure or to reestablish utility service to a structure.

(D) Variance. The Director of Health, in accordance with [section 22.76](#) of the Code of Ordinances of the City of Garland, may issue a permit of variance to these regulations.

Chapter 1 "general", article 100 "definitions", I. "general" shall be amended by adding the following definitions:

Approved, as to materials, equipment and method of construction, refers to approval by the Building Official as the result of investigation and tests conducted by him, or by reason of accepted principles or tests by recognized authorities, technical or scientific organizations.

Approved agency is an established and recognized agency regularly engaged in conducting tests or furnishing inspection services, when such agency has been approved by the Building Official.

Building Code is the Building Code as adopted by the City.

Building Official is the officer charged with the administration and enforcement of this Code, or his duly authorized representative, and is the authority having jurisdiction for this Code.

Electrical Code is the National Electrical Code promulgated by the National Fire Protection Association, as adopted by the City.

Electrical system. In this article, any reference to electrical system shall mean electrical conductors, equipment, and raceways; signaling and communications conductors, equipment, and raceways; and optical fiber cables and raceways.

Multiple occupancy building is a building having more than one tenant and may be of single or mixed use groups as classified by the Building Code.

Article 110.3 "Examination, identification, installation, and use of equipment" shall be amended by adding subsection (C) through (K) as follows.

(C) Testing:

(1) Whenever there is insufficient evidence of compliance with any of the provisions of this Code, or evidence that materials or construction do not conform to the requirements of this Code, the Building Official may require tests as evidence of compliance to be made at the sole expense of the person providing such materials or performing such construction.

(2) Test methods shall be as specified by this Code or by other recognized test standards. In the absence of recognized and accepted test methods for the proposed alternate, the Building Official may determine test procedures.

(3) All tests shall be made by an approved agency and a report indicating the results of such tests filed with the Building Official. Reports of such tests shall be retained by the Building Official for a period deemed appropriate by the Building Official.

(D) Additions, alterations or repairs.

(1) Additions, alterations or repairs may be made to any electrical system and equipment without requiring the entire existing electrical system to be upgraded to meet this Code, provided that any addition, alteration or repair conforms to the requirements for a new electrical system and provided further that no hazard to life, health or safety will be created by such additions, alterations or repairs.

(2) Minor additions, alterations and repairs to existing electrical systems and equipment may be made in accordance with the law in effect at the time the original installation was made, when approved by the Building Official.

(E) Existing installations. Electrical systems and equipment lawfully in existence at the time of the adoption of this Code may have their use, maintenance or repair continued if the use, maintenance or repair is in accordance with the original design and no hazard to life, health or property has been created by such electrical system and equipment. Except in regards to electrical service, meter base, panel and breakers that are being replaced-repaired, whereas the replacement-repair would need to meet 2014 NEC and utility service provider specifications. Example #1. If existing panel was in a closet the new panel may not be installed in a closet. Example #2 .If meter base is repaired or replaced the height must be installed per utility company specifications. Example #3. If overhead service being repaired or replaced the point of attachment may not be lower than 2014 NEC standards and meet utility company requirements. Example #4. Existing panel must be grounded and if the existing panel is the first means of disconnect it must have no more than 6 disconnecting means to remove power from all circuits.

(F) Change in building occupancy. Electrical

systems and equipment which are a part of any building or structure undergoing a change in use or occupancy, as defined in the Building Code, shall comply with the requirements of this Code which are applicable to the new use or occupancy.

(G) Maintenance. All electrical systems and equipment, both existing and new, and all parts thereof shall be maintained in a proper operating condition in accordance with the original design and in a safe and hazard-free condition. All devices or safeguards which are required by this Code shall be maintained in conformance with this Code. The owner or his designated agent shall be responsible for the maintenance of the electrical system. To determine compliance with this subsection, the Building Official may cause any electrical system to be reinspected.

(H) Moved building. Electrical systems and equipment which are a part of buildings or structures moved into or within the City shall comply with the provisions of this Code for new installations.

(I) Appliances in attics. Attics containing appliances requiring access for maintenance, repair, or replacement shall be provided with an opening and unobstructed passageway large enough to allow removal of the largest appliance. The passageway shall not be less than 30 inches high and 22 inches wide and not more than 20 feet in length measured along the centerline of the passageway from the opening to the appliance. The passageway shall have continuous unobstructed solid flooring not less than 22 inches wide. A level service space not less than 30 inches deep and 30 inches wide shall be present at the front or service side of the appliance. The clear access opening dimensions shall be a minimum of 20 inches by 30 inches or shall be larger where such dimensions are not large enough to allow removal of the largest appliance. As a minimum, access to the attic space shall be provided by one of the following:

1. A permanent stair;

2. A pull down stair with a minimum 300 lb. capacity;
3. An access door from an upper floor level;  
or
4. An access panel may be used in lieu of items 1, 2, or 3 with prior approval of the Building Official due to building conditions.

Exception: The passageway and level service space are not required where the appliance is capable of being removed through the required.

(J) Equipment and appliances on roofs or elevated structures. Where equipment or appliances requiring access for maintenance, repair, or replacement are installed on roofs or elevated structures at an aggregate height exceeding 16 feet, such access shall be provided by a permanent approved means of access. Permanent exterior ladders providing roof access need not extend closer than 12 feet to the finish grade or floor level below and shall extend to the equipment or appliance's level service space. Such access shall not require climbing over obstructions greater than 30 inches high or walking on roofs having a slope greater than 4 units vertical in 12 units horizontal (33-percent slope).

(K) Sloped roofs. Where appliances, equipment, fans or other components that require service for maintenance, repair, or replacement are installed on roofs having slopes greater than 4 units vertical in 12 units horizontal and having an edge more than 30 inches above grade at such edge, a catwalk at least 16 inches in width with substantial cleats spaced not more than 16 inches apart shall be provided from the roof access to a level platform at the appliance. The level platform shall be provided on each side of the appliance to which access is required for service, repair or maintenance. The platform shall be not less than 30 inches in any dimension

and shall be provided with guards. The guards shall extend not less than 42 inches above the platform, shall be constructed so as to prevent the passage of a 21-inch-diameter sphere and shall comply with the loading requirements for guards specified in the International Building Code.

Article 230.2 "Number of services", (A) "special conditions" is amended by adding a subsection (7) as follows:

(7) In supplying electrical service to multifamily dwellings, two or more laterals or overhead service drops shall be permitted to a building when both of the following conditions are met:

(a) The building has six or more individual gang meters and all meters are grouped at the same location.

(b) Each lateral or overhead service drop originates from the same point of service.

Article 230.70 "general" (1) "readily accessible location" is amended to read as follows:

(1) Ready accessible location. The service disconnecting means shall be installed at a readily accessible location either outside of a building or structure or inside the nearest point of entrance of the service conductors. If located inside, the disconnecting means must to be located not more than 5 feet from an exterior wall and a passage door installed to allow access to the equipment. The door must have a permanent sign stating that the electrical disconnecting means is directly inside - ELECTRIC ROOM. Upon entry from the exterior the equipment needs to be insight and readily accessible. Lettering at the exterior door the must be 2" tall and 1/2" wide and be visible from the utility company power source.

Article 230.71 "Maximum number of disconnects", (A) "general" is amended by adding the following exception.

Exception: Multi-occupant buildings. Individual service disconnecting means is limited to six for each occupant. The number of individual disconnects at one location may exceed six.

Article 310.15 "Ampacities for conductors rated 0-2,000 Volts", (B) "tables", (7) 120/240 volt, single-phase dwelling services and feeders" is amended by adding subsection (5) as follows:

(5) This article shall not be used in conjunction with article 220.82.

Article 600.6 "Disconnects" (A) "location" (2) "within sight of the sign" is amended to read as follows:

(2) Within sight of the sign. The disconnecting means shall be within sight of the sign or outline lighting system that it controls. Where the disconnecting means is out of line of sight from any section that is able to be energized, the disconnecting means shall be lockable in accordance with 100.25. The disconnecting means shall be readily accessible.

Article 600.6 "Disconnects" (A) "location" (3) "within sight of the controller" is amended by adding subsection (4) as follows:

(4) The disconnecting means shall be readily accessible.

Article 680.25 "feeders" (A) "wiring methods" (1) "feeders" is amended by adding the following permissible wiring methods:

(7) Nonmetallic-sheathed cable.

(8) Type SE cable."

#### **Section 4**

That Section 30.81, "Amendments, modifications and deletions to the International Plumbing Code", of Chapter 30, "Building Inspection", of the Code of Ordinances of the City of Garland, Texas, is amended to read as follows:

**"Section 30.81 Amendments, modifications and deletions to the International Plumbing Code**

The following sections of the International Plumbing Code ("Plumbing Code"), as adopted in [section 30.80](#), are amended, modified, or deleted as follows:

Section 102.8 Referenced Codes and standards shall be amended to read as follows:

102.8 Referenced Codes and standards. The Codes and standards referenced in this Code shall be those that are listed in chapter 15 and such Codes, when specifically adopted, and standards shall be considered as part of the requirements of this Code to the prescribed extent of each such reference. Where the differences occur between provisions of this Code and the referenced standards, the provisions of this Code shall be the minimum requirements. Whenever amendments have been adopted to the referenced Codes and standards, each reference to said Code and standard shall be considered to reference the adopted amendments. Any reference to NFPA 70 or the National Electrical Code (NEC) shall mean the Electrical Code as adopted.

Section 109 of the International Plumbing Code is amended in its entirety and shall read as follows:

(A) Appeals. Any person aggrieved by any decision or ruling made by the Building Official under the provisions of this Article V, "Plumbing Code," may appeal to the Unified Building Standards Commission.

(B) Appeal Procedures. The provisions, procedures, rules, and deadlines of [Section 30.02](#) shall apply to all appeals made under this Article V, "Plumbing Code."

Section 305.4.1 Sewer depth shall be amended to read as follows:

305.4.1 Sewer depth. Building sewers shall be a minimum of 12 inches (304 mm) below grade.

Section 305.7 protection of components of plumbing system shall be amended to read as follows:

305.7 Protection of components of plumbing system. Components of a plumbing system installed within 3 feet along alleyways, driveways, parking garages or other locations in a manner in which they could be exposed to damage shall be recessed into the wall or otherwise protected in an approved manner.

Section 305.10 Exterior hydrants shall be amended by adding a new section to read as follows:

305.10 Exterior hydrants. Exterior hydrants installed through the walls shall be installed with a copper or brass pipe nipple from the threaded female drop ear ninety-degree elbow to the water hydrants with an appropriate vacuum breaker. Frost-proof hydrants shall be installed when subject to freezing.

Section 312.2 Drainage and vent water test shall be amended to read as follows:

312.2 Drainage and vent water test. A water test shall be applied to the drainage system either in its entirety or in sections. If applied to the entire system, all openings in the piping shall be tightly closed, except the highest opening, and the system shall be filled with water to the point of overflow. If the system is tested in sections, each opening shall be tightly plugged except the highest opening of the section under test, and each section shall be filled with water, but no section shall be tested with less than a 5 foot head of water. In testing successive sections, at least the upper 5 feet of the next preceding section shall be tested so that no joint or pipe in the building, except the uppermost 5 feet of the system shall have been

submitted to a test of less than 5 foot head of water. The water shall be kept in the system, or in the portion under test, for at least 15 minutes before inspection starts. The system shall then be tight at all points.

Section 312.9.2 Inspection and testing of backflow prevention assemblies shall be amended by adding a new section to read as follows:

312.9.2 Inspection and testing of backflow prevention assemblies. Testing shall comply with the City's crossconnection control regulations. Crossconnection control regulations are set forth in [article V, chapter 51](#) of the Code of Ordinances.

Section 312.10.1 Inspections shall be amended to read as follows:

312.10.1 Inspections. Annual inspections shall be made of all backflow prevention assemblies and air gaps to determine whether they are operable. In the absence of an authorized inspection by the City, the owner is responsible to ensure that proper testing is performed.

Section 312.10.2 Testing shall be amended to read as follows:

312.10.2 Testing. Reduced pressure principle backflow preventer assemblies, double check-valve assemblies, pressure vacuum breaker assemblies, reduced pressure detector fire protection backflow prevention assemblies, double check detector fire protection backflow prevention assemblies, hose connection backflow preventers, and spill-proof vacuum breakers shall be tested at the time of installation, immediately after repairs or relocation and at least annually. The testing procedure shall be performed in accordance with applicable local provisions. In the absence of local provisions, the owner is responsible to ensure that testing is done in accordance with one of the following standards: ASSE 5013, ASSE 5015, ASSE 5020, ASSE 5047, ASSE 5048, ASSE 5052, ASSE 5056, CSA B64.10 or CSA

B64.10.1.

Section 314.2.1 Condensate disposal shall be amended to read as follows:

314.2 .1 Condensate disposal. Condensate from all cooling coils and evaporators shall be conveyed from the drain pan outlet to an approved place of disposal. Such piping shall maintain a minimum horizontal slope in the direction of discharge of not less than one-eighth unit vertical in 12 units horizontal (1-percent slope). Condensate shall not discharge into a street, alley, sidewalk, rooftop, or other areas so as to cause a nuisance.

Section 401.1 Scope shall be amended by adding a sentence to read to the end of the section to read as follows:

The provisions of this chapter of the Plumbing Code are meant to work in coordination with the provisions of the Building Code. Should any conflicts arise between these two Codes, the Building Official shall determine which provision will control, the presumption being that the more restrictive provision will apply.

Section 403.1 Minimum number of fixtures shall be amended to read as follows:

403.1 Minimum number of fixtures. Plumbing fixtures shall be provided for the type of occupancy and in the minimum number as follows:

1. Assembly occupancies. At least one drinking fountain shall be provided at each floor level in an approved location.

Exception: A drinking fountain need not be provided in a drinking or dining establishment.

2. Groups A, B, F, H, I, M and S occupancies: Buildings or portions thereof where persons are employed shall be provided with at least one water closet for each sex except as provided for in section 403.2.

3. Group E occupancies: Shall be provided with fixtures as shown in table 403.1.

4. Group R occupancies: Shall be provided with fixtures as shown in table 403.1.

It is recommended, but not required, that the minimum number of fixtures provided also comply with the number shown in table 403.1. Types of occupancies not shown in table 403.1 shall be considered individually by the Building Official. The occupancy classification and the number of occupants shall be determined by the Building Code.

Section 410.1 Approval shall be amended to read as follows:

410.1 Approval. Drinking fountains shall conform to ASME A112.19.1M, ASME A112.19.2M or ASME A112.19.9M, and water coolers shall conform to ARI 1010. Drinking fountains and water coolers shall conform to NSF 61, section 9. (See section 403.1 of the Plumbing Code, as adopted and amended, to determine the occupancies that require drinking fountains and water coolers.) Electrically operated, refrigerated drinking water coolers shall be listed and labeled in accordance with UL 399.

Section 412.2.1 Required location shall be added to read as follows:

412.2.1 Required location. Floor drains shall be installed in the following areas:

1. In public coin-operated laundries and in the central washing facilities of multiple-family dwellings, the rooms containing automatic clothes washers shall be provided with floor drains located to readily drain the entire floor area. Such drains shall have a minimum outlet of not less than 3 inches in diameter.

2. Commercial kitchens. In lieu of floor drains kitchens the Building Official may

accept floor sinks.

3. Public restrooms.

Section 417.5.2 Shower lining shall be amended to read as follows:

417.5.2 Shower lining. Floors under shower compartments, except where prefabricated receptors have been provided, shall be lined and made watertight utilizing material complying with sections 417.5.2.1 thru 417.5.2.5 of the Plumbing Code. Such liners shall turn up on all sides at least 2 inches above the finished threshold level and shall extend outward over the threshold and fastened to the outside of the threshold jamb. Liners shall be recessed and fastened to an approved backing so as not to occupy the space required for wall covering, and shall not be nailed or perforated at any point less than 1 inch above the finished threshold. Liners shall be pitched one-fourth unit vertical in 12 units horizontal (2-percent slope) and shall be sloped toward the fixture drains and be securely fastened to the waste outlet at the seepage entrance, making a water-tight joint between the liner and the outlet. The completed liner shall be tested in accordance with sections 312.9 and 417.7 of the Plumbing Code.

Section 417.7 Test for shower lining shall be adding as a new section to read as follows:

417.7 Test for shower lining. Shower receptors shall be tested for water tightness by filling with water to the level of the rough threshold. The drain shall be plugged in a manner so that both sides of pans shall be subjected to the test at the point where it is clamped to the drain.

Section 502.3 Water heaters installed in attics, shall be amended by adding the following to end of the section as follows:

502.3 Water heaters installed in attics. Attics containing a water heater shall be provided with an opening and unobstructed passageway large

enough to allow removal of the water heater. The passageway shall not be less than 30 inches in height and 22 inches in width and not more than 20 feet in length when measured along the centerline of the passageway from the opening to the water heater. The passageway shall have continuous solid flooring not less than 24 inches in width. A level service space not less than 30 inches in length and 30 inches in width shall be present at the front or service side of the water heater. The clear access opening dimensions shall be a minimum of 20 inches by 30 inches (508 mm by 762 mm), or larger where such dimensions be not less than 20 inches by 30 inches (508 mm by 762 mm) where such dimensions are large enough to allow removal of the water heater. A walkway to an appliance shall be rated as a floor as approved by the Building Official. As a minimum, for access to the attic space, provide one of the following:

1. A permanent stair.
2. A pull down stair with a minimum 300 lb (136 kg) capacity.
3. An access door from an upper floor level.
4. Access panel may be used in lieu of items 1, 2, and 3 with prior approval of the Code Official due to building conditions.

Section 502.6 Water heaters above ground or floor shall be added as a new section as follows:

502.6 Water heaters above ground or floor. When the attic, roof, mezzanine or platform in which a water heater is installed is more than eight (8) feet (2438 mm) above the ground or floor level, it shall be made accessible by a stairway or permanent ladder fastened to the building.

Exception: A max 10 gallon water heater (or larger with approval) is capable of being accessed through a lay-in ceiling and a water heater is installed is not more than ten (10) feet (3048 mm) above the ground or floor level

and may be reached with a portable ladder.

502.6.1 Illumination and convenience outlet.  
Whenever the mezzanine or platform is not adequately lighted or access to a receptacle outlet is not obtainable from the main level, lighting and a receptacle outlet shall be provided in accordance with section 502 .1 of the Plumbing Code.

Section 504.6 Requirement for discharge piping shall be amended to read as follows:

504.6 Requirements for discharge piping. The discharge piping serving a pressure relief valve, temperature relief valve or combination thereof shall:

1. Not be directly connected to the drainage system.
2. Discharge through an air gap.
3. Not be smaller than the diameter of the outlet of the valve served and shall discharge full size to the air gap.
4. Serve a single relief device and shall not connect to piping serving any other relief device or equipment.

Exception: Multiple relief devices may be installed to a single T & P discharge piping system when approved by the Building Official and permitted by the manufacture's installation instructions and installed per those instructions.

5. Discharge to an indirect waste receptor or to the outdoors. Where discharging to the outdoors in areas subject to freezing, discharge piping shall be first piped to an indirect waste receptor through an air gap located in a conditioned area.
6. Discharge in a manner that does not cause personal injury or structural damage.

7. Discharge to a termination point that is readily observable by the building occupants.
8. Not be trapped.
9. Be installed so as to flow by gravity.
10. Not terminate less than 6 inches or more than 24 inches above grade.
11. Not have a threaded connection at the end of such piping.
12. Not have valves or tee fittings.
13. Be constructed of those materials listed in section 605.4 or materials tested, rated and approved for such use in accordance with ASME A112.4.1.

Section 504.7.1 Pan size and drain shall be amended to read as follows:

504.7.1 Pan size and drain. The pan shall be not less than 1-1/2 inches (38 mm) in depth and shall be of sufficient size and shape to receive all dripping or condensate from the tank or water heater. The pan shall be drained by an indirect waste pipe having a diameter of not less than 3/4 inch (19 mm). Piping for safety pan drains shall be of those materials listed in table 605.4. Multiple pan drains may terminate to a single discharge piping system when approved by the administrative authority and permitted by the manufactures installation instructions and installed with those instructions.

Section 604.4.1 State maximum flow rate shall be added as a new section as follows:

604.4.1 State maximum flow rate. Where the State mandated maximum flow rate is more restrictive than those of this section, the State flow rate shall take precedence.

Section 606.1 Location of full-open valves shall be amended by deleting items 4 and 5.

Section 606.2 Location of shutoff valves shall be amended by deleting item 2.

Section 608.1 General shall be amended to read as follows:

608.1 General. A potable water supply system shall be designed, installed and maintained in such a manner so as to prevent contamination from nonpotable liquids, solids or gases being introduced into the potable water supply through crossconnections or any other piping connections to the system. Backflow preventer applications shall conform to the City's crossconnection control regulations, table 608.1 of the Plumbing Code, except as specifically stated in sections 608.2 thru 608.16.10.

Section 608.16.5 Connections to lawn irrigation systems shall be amended to read as follows:

608.16.5 Connections to lawn irrigation systems. The potable water supply system to lawn irrigation systems shall be protected against backflow by an atmospheric type vacuum breaker, a pressure type vacuum breaker, a double-check assembly or a reduced pressure principle backflow preventer. A valve shall not be installed downstream from an atmospheric vacuum breaker. Where chemicals are introduced into the system, the potable water supply shall be protected against backflow by a reduced pressure principle backflow preventer.

Section 608.17 Protection of individual water supplies shall be amended to read as follows:

608.17 Protection of individual water supplies. An individual water supply shall be located and constructed so as to be safeguarded against contamination in accordance with the City's crossconnection control program. When not regulated by the City's crossconnection control program, installation shall be in accordance with sections 608.17.1 thru 608.17.8 of the Plumbing

Code.

Section 610.1 General shall be amended to read as follows:

610.1 General. New or repaired potable water systems shall be purged of deleterious matter and disinfected prior to utilization. The method to be followed shall be that prescribed by the health authority or water purveyor having jurisdiction or, in the absence of a prescribed method, the procedure described in either AWWA C651 or AWWA C652, or as described in this section. This requirement shall apply to "on-site" or "in-plant" fabrication of a system or to a modular portion of a system.

1. The pipe system shall be flushed with clean, potable water until dirty water does not appear at the points of outlet.

2. The system or part thereof shall be filled with a water/chlorine solution containing at least 50 parts per million (50 mg/l) of chlorine, and the system or part thereof shall be valved off and allowed to stand for 24 hours; or the system or part thereof shall be filled with a water/chlorine solution containing at least 200 parts per million (200 mg/l) of chlorine and allowed to stand for 3 hours.

3. Following the required standing time, the system shall be flushed with clean potable water until the chlorine is purged from the system.

4. The procedure shall be repeated where shown by a bacteriological examination that contamination remains present in the system.

Exception: With prior approval the Code Official may wave this requirement when deemed unnecessary.

Section 701.2.1 Availability determination shall be adding as a new section to read as follows:

701.2 .1. Availability determination. The availability of the public sewer to the building, lot or premises shall be determined by the City Director of Engineering.

Section 703.6 Combined sanitary and storm public sewer shall be deleted in its entirety.

Section 704.5 Single stack fittings shall be added as a new section to read as follows:

704.5 Single stack fittings. Single stack fittings with internal baffle, PVC schedule 40 or cast iron single stack shall be designed by a registered engineer and comply to a national recognized standard.

Section 705.11.2 Solvent cementing shall be amended by deleting the exceptions in their entirety.

Table 710.1(1) Building drains and sewers and table 710.1(2) horizontal fixtures branches and stacks shall be amended by adding a footnote "d." to read as follows:

d. Minimum 2 inch DWV piping is required below the first floor level of a slab on grade or similar foundation. {Annotation "d" to be placed after each table title.}

Section 712.5 Dual pump system shall be added as a new section as follows:

712.5 Dual pump system. All sumps shall be automatically discharged and, when in any "public use" occupancy where the sump serves more than 10 fixture units, shall be provided with dual pumps or ejectors arranged to function independently in case of overload or mechanical failure. For storm drainage sumps and pumping systems, see section 1113.

Section 714 Title shall be amended as follows:

SECTION 714  
ENGINEERED DRAINAGE DESIGN

Section 714.1 Design of drainage system shall be amended to read as follows:

714.1 Design of drainage system. The sizing, design and layout of the drainage system shall be designed by a registered engineer using approved design methods.

Section 804.2 Special waste pipe, fittings and components shall be added as a new section to read as follows:

804.2 Special waste pipe, fittings, and components. Pipes, fittings and components receiving or intended to receive the discharge of any fixture into which acid or corrosive chemicals are placed shall be constructed of CPVC, high silicone iron, PP, PVDF, chemical resistant glass, or glazed ceramic materials.

Section 904.1 Roof extension shall be amended to read as follows:

904.1 Roof extension. Open vent pipes that extend through a roof shall be terminated not less than 6 inches above the roof. Where a roof is to be used for assembly or as a promenade, observation deck, sunbathing deck or similar purpose, open vent pipes shall terminate not less than 7 feet above the roof.

Section 915.1 Type of fixture shall be amended to read as follows:

915.1 Type of fixture. A combination waste and vent system shall not serve fixtures other than standpipes, floor drains, sinks, lavatories and drinking fountains. Combination waste and vent systems shall not receive the discharge from food waste disposer or clinical sink.

Section 915.2 Installation shall be amended to read as follows:

915.2 Installation. The only vertical pipe of a combination drain and vent system shall be the connection between the fixture drain of a sink,

standpipe, and the horizontal combination drain and vent pipe. The maximum vertical distance shall be 8 feet.

Section 917 Single stack vent system shall be deleted in its entirety.

Section 918.2.1 Installation approval shall be adding as a new section to read as follows:

918.2.1 Installation approval. The installation of air admittance valves shall not be permitted without first obtaining permission from the Building Official. The valves shall be installed in accordance with the requirements of this section and the manufacturer's installation instructions. Installation plans for air admittance valve systems must be submitted, in duplicate, specifically showing the location of all air admittance valves, relief vents, and vent stacks. One copy of the approved plan shall be required to remain on the jobsite until all inspections are completed. Air admittance valves shall be installed after the DWV testing required by Plumbing Code section 312.2 or 312.3 has been performed.

Section 1002.10 Plumbing in mental health centers shall be deleted in entirety.

Section 1003.2 Approval shall be amended to read as follows:

1003.2 Approval. The size, type and location of each interceptor and of each separator shall be designed and installed in accordance with the City's Health Department requirements, manufacture's instruction and the requirements of this section based on the anticipated conditions of use. Wastes that do not require treatment or separation shall not be discharged into any interceptor or separator.

Section 1003.3 Grease interceptors, shall be amended to read as follows:

1003.3 Grease interceptors. Grease interceptors

shall comply with all requirement established by the City and shall comply with the requirements of sections 1003.3.1 through 1003.3.5.

Section 1106.1 General shall be amended to read as follows:

1106.1 General. The size of the vertical conductors and leaders, building storm drains, building storm sewers, and any horizontal branches of such drains or sewers shall be based on the 100-year hourly rainfall rate of 6 inches per hour.

Section 1101.8 Cleanouts required shall be amended to read as follows:

1101.8 Cleanouts required. Cleanouts or manholes shall be installed in the storm drainage system and shall comply with the provisions of this Code for sanitary drainage pipe cleanouts.

Section 1108.3 Sizing of secondary drains shall be amended to read as follows:

1108.3 Sizing of secondary drains. Secondary (emergency) roof drain systems shall be sized in accordance with section 1106 of the Plumbing Code. Scuppers shall be sized to prevent the depth of ponding water from exceeding that for which the roof was designed as determined by section 1101.7 of the Plumbing Code. Scuppers shall not have an opening dimension of less than 4 inches. The flow through the primary system shall not be considered when sizing the secondary roof drain system.

Section 1109 Combined sanitary and storm public sewer shall be deleted in its entirety.

Section 1202.1 Nonflammable medical gases shall be amended by deleting exception 2."

## **Section 5**

That Section 30.226, "Amendments, modifications and deletions", of Chapter 30, "Building Inspection", of the

Code of Ordinances of the City of Garland, Texas, is hereby amended to read as follows:

**"Section 30.226 Amendments, modifications, and deletions**

The following sections of the 2015 International Residential Code, as adopted in [section 30.225](#) of the Code of Ordinances, are amended, modified or deleted as described below:

Section 101.1 Title shall be amended to read as follows:

R101.1 Title. These regulations shall be known as the Residential Code of the City of Garland, hereinafter referred to as the "Residential Code."

Section R101.2 Scope, shall be amended by amending the exception to read as follows:

Exception: At the discretion of the Building Official, existing buildings undergoing repair, alteration or additions, and change of occupancy may with prior approval be permitted to comply with the appendix J of this Code or with the International Existing Building Code.

Section R102.4.1 Conflicts shall be amended to read as follows:

R102.4.1 Conflicts. Where conflicts occur between provisions of this Code and referenced Codes and standards the provisions of this Code shall apply.

Where differences occur between provisions of this Code and the Code of Ordinances the provisions of the Code of Ordinances shall control.

Section R103.1 Enforcement agency, shall be amended to read as follows:

R103.1 Enforcement agency. The Building Inspection Department shall enforce the provisions of this Code. The official in charge

shall be the Building Official.

Section R105.2 Work exempt from permit, shall be amended to read as follows:

R105.2 Work exempt from permit. Exemption from permit requirements of this Code shall not be deemed to grant authorization for any work to be done in any manner in violation of the provisions of this Code or any other laws, or ordinances of the City of Garland. Permits shall not be required for the following:

Building:

1. Dog houses or detached accessory buildings not exceeding 20 square feet.
2. Minor foundation repair or minor roof repair of less than \$2,000.00.
3. Retaining walls that are not over 4 feet in height measured from the bottom of the footing to the top of the wall, unless supporting a surcharge. See R404.4 of the Residential Code for additional requirements on unbalanced fill.
4. Decks not exceeding 200 square feet in area, that are not attached to a dwelling and do not obstruct the exit door required by section R311.4. Uncovered decks not over 30 inches above grade.
5. Painting, papering, tiling, carpeting, counter tops, cabinets and similar finish work.
6. Prefabricated swimming pools that are less than 24 inches deep.
7. Swing sets, playhouses, children's forts, and tree housed not larger than 100 square feet located entirely in the rear yard.
8. Window awnings support by an exterior wall that do not project more than 54 inches

from the exterior wall and do not require additional support, provided they do not extend into the required front yard or closer than 3 feet to a side or rear property line when fully extended.

{Balance of section unchanged}

Section R105.5 Expiration shall be amended to read as follows:

R105.5 Expiration. An individual permit issued by the Building Official shall expire by limitation and become null and void on the expiration of 2 years after its issuance if no progress has been made toward the completion of the project, or upon expiration of the project. (A project shall expire immediately after the fifth anniversary of the date the first permit application was filed for the project if no progress had been made towards completion of the project.) Once a permit for particular work has expired, a new permit must be applied for and obtained before the work can be commenced. The permit fee shall be the full amount required for a new permit for such work. The Building Official shall determine the extent to which the work must comply with any new regulations that were not in effect at the time the original permit was issued.

Section R105.10 shall be amended by adding a new section and subsection to read as follows:

R105.10 Contractor registration and supervision of work. Any person providing services as a building, electrical, mechanical, roofing, irrigation, fire sprinkler or plumbing contractor in the City shall register with the Building Inspection Department as a contractor. Application shall be made in writing on forms furnished for that purpose and filed with the Building Official. The application shall show the contractor's name, local address and telephone number, a copy of the contractor's state license or registration (if applicable), and such other information as may reasonably be required to properly identify the contractor. Such

registration shall include payment of a fee as prescribed in the fee schedule located in [article XVI of chapter 30](#) of the Code of Ordinances.

R105.10.1 Roofing contractors. Any roofing or roofing repair work that exceeds \$2,000.00 must be performed by a contractor registered in conformance with R105.10. As a condition of the registration the roofing contractor shall provide the City with a certificate of insurance issued by a company or companies authorized to transact business in Texas and rated at least "A" or AM Best or other equivalent insurance rating service. A contractor must have and maintain, throughout the performance of the roofing work, a policy or policies of insurance for bodily injury, death and property damage insuring against all claims, demands or actions relating to the contractor's performance of its work with (1) a policy of comprehensive general liability insurance with combined single limit of not less than \$300,000.00 per occurrence for bodily injury and property damage with an aggregate of not less than \$600,000.00 and an aggregate of not less than \$300,000.00 for products and completed operations; and (2) a policy of automobile liability insurance covering any vehicles owned and/or operated by the contractors, its officers, agents, and employees, and used in the performance of its roofing work with minimum coverage of as provided by the Texas Transportation Code. A certificate of insurance evidencing the required insurance will be submitted by the contractor to the owner of the dwelling unit upon request. The roofing permit shall contain the following notice:

'Your roofing contract may be subject to chapter 58, Texas Business and Commerce Code. That law provide that, for disaster remediation work, unless your contractor has maintained a physical business address in either Dallas County, Texas or a county adjacent to Dallas County for at least one year preceding the date of your roofing contract, then your roofing contractor may not require full or partial payment (such as

a deposit or down-payment) before the contractor begins work and, after the work begins, may not require partial payments in an amount that exceeds an amount reasonably proportionate to the work performed, including any materials delivered.'

Section R106.1 Submittal documents shall be amended by adding a sentence to the end of the section to read as follows:

The Building Official may require documents to be submitted in an electrical format as an alternate to paper copies.

Section R109.1.5.2 Erosion control shall be amended by adding a new subsections to read as follows:

R109.1.5.2 Erosion control. Erosion control inspection will be conducted at various time during the construction process.

Section R109.5.3 Special inspector shall be amended by adding a new subsection to read as follows:

R109.1.5.3 Special inspector. In addition to the inspections required by the Residential Code, the owner shall employ a special inspector specialized in that type of construction during construction when deemed necessary by the Building Official.

Section R110 Certificate of occupancy is deleted in its entirety.

Section R112 Board of Appeals, of the International Residential Code is amended in its entirety and shall read as follows:

(A) Appeals. Any person aggrieved by any decision or ruling made by the Building Official under the provisions of this Article XIII, "Residential Code," may appeal to the Unified Building Standards Commission.

(B) Appeal Procedures. The provisions, procedures, rules, and deadlines of Section

30.02 shall apply to all appeals made under this Article XIII, "Residential Code."

Section R115 Working hours, shall be amended by adding a new section to read as follows:

SECTION R115  
WORKING HOURS

R115.1 Construction hours established. Any outside work being done adjacent to an occupied residential subdivision or adjacent to an occupied residential use, including multifamily uses, shall be allowed only between 7:00 a.m. and 8:00 p.m. each day of the week. Any outside work being done adjacent to an occupied residential subdivision or adjacent to an occupied residential use including multifamily uses, shall be prohibited between the hours of 8:00 p.m. and 7:00 a.m. each day of the week.

R115.2 Other regulations unaffected. This section does not authorize violation of any other legally established regulation, either public or private, regulating noise nuisance to residents.

R115.3 Exceptions. These regulations do not affect emergency work being done to secure a structure or to reestablish utility service to a structure.

R115.4 Variance. The Director of Health, in accordance with section 22.76 of the Code of Ordinances of the City, may issue a permit of variance to these regulations.

Section R202 Definitions shall be amended to redefine the following terms:

ACCESSORY STRUCTURE. A subordinate building, containing more than 20 square feet of area and more than 4 feet in height, which is detached from the main building and is clearly secondary and incidental to the main building on, and use of, the property.

TOWNHOUSE. A single-family dwelling unit constructed in a

group of three or more attached units separated by property lines in which each unit extends from foundation to roof and with a yard or public way on at least two sides.

Table R301.2(1) Climatic and geographic design criteria table shall be amended by completing the table as follows:

Ground Snow Load...51b/ft<sup>2</sup>

Wind Design

Speed...115(3sec-gust)/76 fastest mile

Topographic effects...No

Special wind region...No

Wind-borne debris zone...No

Seismic Design Category...A

Subject to Damage From:

Weathering...Moderate

Frost line depth...6 inches

Termite... Very Heavy

Winter Design Temp...22°F

Ice Barrier Underlayment Required... No

Flood Hazards...Local Code

Air Freezing Index...69

Mean Annual Temp...64.6°F

Section R302.1 Exterior wall, shall be amended to read as follows:

R302.1 Exterior walls. Exterior walls with a fire separation distance less than 3 feet shall have not less than a one-hour fire-resistive rating with exposure from both sides. Projections shall not extend to a point closer than 2 feet from the

line used to determine the fire separation distance.

Exception: Detached garages accessory to a dwelling located within 2 feet of a lot line may have roof eave projections not exceeding 4 inches.

Projections extending into the fire separation distance shall have not less than one-hour fire resistive construction on the underside. The above provisions shall not apply to walls which are perpendicular to the line used to determine the fire separation distance.

Exceptions:

1. Structures exempted from permits by R105.2 are not required to provide wall protection based on location on the lot. Projections beyond the exterior wall shall not extend over the lot line.
2. Open metal carport structures may be constructed on the property line without fire-resistive or opening protection when the location of the carport is approved as provided by the Code of Ordinances.
3. Type U occupancies (not garages or carports), less than 145 square feet in size need not be separated from the use to which they are an accessory.

Section R302.2 Townhouses shall be amended by amending its applicable exception to read as follows:

Exception: A common two-hour fire-resistance-rated wall assembly, or one-hour fire-resistance-rated wall assembly, when equipped with a sprinkler system, is permitted for townhouses if such walls do not contain plumbing or mechanical equipment, ducts or vents in the cavity of the common wall. The wall shall be rated for fire exposure from both sides and shall extend to and be tight against exterior walls and the underside of the roof sheathing. Electrical installations

shall be installed in accordance with chapters 34 through 43 of the Residential Code. Penetrations of electrical outlet boxes shall be in accordance with section R302.4.

Section R302.2.4 Structural independence shall be amended by amending exception 5 to read as follows:

5. Townhouses separated by a common two-hour fire resistance-rated wall, or one-hour fire resistant rated wall, when equipped with an automatic sprinkler system.

Section R302.3 Two-family dwellings, shall be amended by adding a new exception to read as follows:

3. Two-family dwelling units that are also divided by a property line through the structure shall be separated as required for townhouses.

Section R303.3 Bathrooms shall be amended by amending its applicable exception to read as follows:

Exception: The glazed areas shall not be required where artificial light and local exhaust systems are provided. The minimum local exhaust rates shall be determined in accordance with section M1507. Exhaust air from the space shall be exhausted out to the outdoors unless the space contains only a water closet, a lavatory or water closet and a lavatory may be ventilated with an approved mechanical recirculating fan or similar device designed to remove odors from the air.

Section R311.2 Egress doors shall be amended by adding an exception to read as follows:

Exception: Exit doors may be provided with a night latch, dead bolt or security chain, provided such devices are mounted at a height not to exceed 48 inches above the finished floor.

Section 313.2 One- and two-family dwellings automatic fire systems shall be amended to read as follows:

R313.2 One- and two-family dwellings automatic

fire systems. An automatic sprinkler system shall be installed in any structure with more than 5,000 square feet of enclosed floor area. For the purpose of this section, a structure includes separate dwelling units that are physically connected, regardless of separation by fire rated walls and property lines. Areas under patio covers and carports shall not be required to be sprinklered.

Section R319.1 Address identification shall be amended to read as follows:

R319.1 Address identification.

(A) Address numbers representing the actual, current, and accurate street address of the premises shall be placed and continuously displayed on any building that constitutes a residential premises.

(B) Address numbers shall:

(1) Be placed and continuously displayed in a position on the building that is readily visible from the street fronting the property;

(2) Be and remain legible;

(3) Contrast with the background on which they are placed;

(4) Consist solely of Arabic numbers or alphabetical letters, as appropriate to accurately reflect the address;

(5) Be not less than 4 inches in height with a stroke width of not less than 0.5 inches; and

(6) Be pre-manufactured or professionally lettered.

(C) Additional address numbering shall be placed and continuously displayed in compliance with subsection (B):

(1) Where required by the Fire Code Official at additional approved locations to facilitate emergency response. Where access is by means of a private road and the building address cannot be viewed from a street, a monument, pole or other sign or means may be required to identify the premises; and

(2) At the rear of the premises if the owner of the premises has maintenance responsibility for the area behind the premises, for example (but not in limitation) if the premises is served by an alley, common area, or easement. A requirement provided by other law or a deed restriction that a premises must have a gate or other access to the adjoining area of responsibility is prima facie evidence that addressing on the rear of the premises is required under this subsection.

Section R320.1 Scope shall be amended to read as follows:

R320.1 Scope. Accessible dwelling units shall comply with the Texas Accessibility Standards as applicable.

Section R322.2.1 Elevations requirements, shall be amended to read as follows:

R322.2.1 Elevation requirements.

1. Buildings and structures in flood hazard area, including flood hazards areas designated as Coastal A Zones, shall have the lowest floor elevation to or above the base flood elevation plus 2 feet or the design flood elevation.

2. In areas of shallow flooding (AO zones), buildings and structures shall have the lowest floor (including basement) elevated to a height of not less than the highest adjacent grade as the depth number specified in feet on the FIRM plus 2 feet, or not less than 3 feet if a depth number is not

specified.

3. Basement floors that are below grade on all sides shall be elevated to or above the base flood elevation plus 2 feet or the design flood elevation, whichever is higher.

Exception: Enclosed areas below the design flood elevation, including basement with floors that are not below grade on all sides shall meet the requirements of section R322.2.2.

Section R401.1 Application shall be amended by adding a new exception to read as follows:

3. In lieu of the requirements of this section, the Building Official may accept an alternative design if the foundation is designed by a professional structural engineer who is licensed by the State of Texas.

Section 401.2.1 Post tension foundations shall be amended by adding a subsection to read as follows:

401.2.1 Post tension foundations. Post tension foundations shall be designed by a professional structural engineer licensed by the State of Texas. Foundation construction shall be certified as meeting the design of the engineer by a special inspector or by the designing engineer.

Section R401.2.2 Foundation repair shall be amended by adding a new section to read as follows:

R401.2.2 Foundation repairs. Foundation repair shall be designed by a professional structural engineer licensed by the State of Texas. Foundation repair shall be certified as meeting the design of the engineer by a special inspector or by the designing engineer.

Section R401.3.1 Grading and drainage shall be amended by adding a new section to read as follows:

R401.3.1 Grading and drainage. Grading and

drainage shall conform with chapter 31, article II, section 31.24 of the City of Garland Code of Ordinances.

Section R401.3.2 Protection to adjoining property shall be amended by adding a new section to read as follows:

R401.3.2 Protection of adjoining property. The requirements for protection of adjacent property and the depth to which the protection is required shall be defined by prevailing law. Lateral support of adjoining property is of a civil nature between adjoining property owners.

Section 602.6.1 Drilling and notching of top plate shall be amended to read as follows:

R602.6.1 Drilling and notching of top plate. When piping or ductwork is placed in or partly in an exterior wall or interior load-bearing wall necessitating cutting, drilling or notching of the top plate by more than 50 percent of its width, a galvanized metal tie not less than 0.054-inch thick and 5 inches wide shall be fastened across and to the plate at each side of the opening with not less than eight 10d (0.148-inch diameter) nails having a minimum length of 1 inches at each side or equivalent. Fasteners will be offset to prevent splitting of the top plate material. The metal tie must extend a minimum of 6 inches past the opening. See figure R602.6.1 below.

Figure R602.6.1 Top plate framing to accommodate piping shall be deleted in its entirety and the following figure shall be inserted in its place:

Figure R602.6.1  
Top Plate Framing to Accommodate Piping

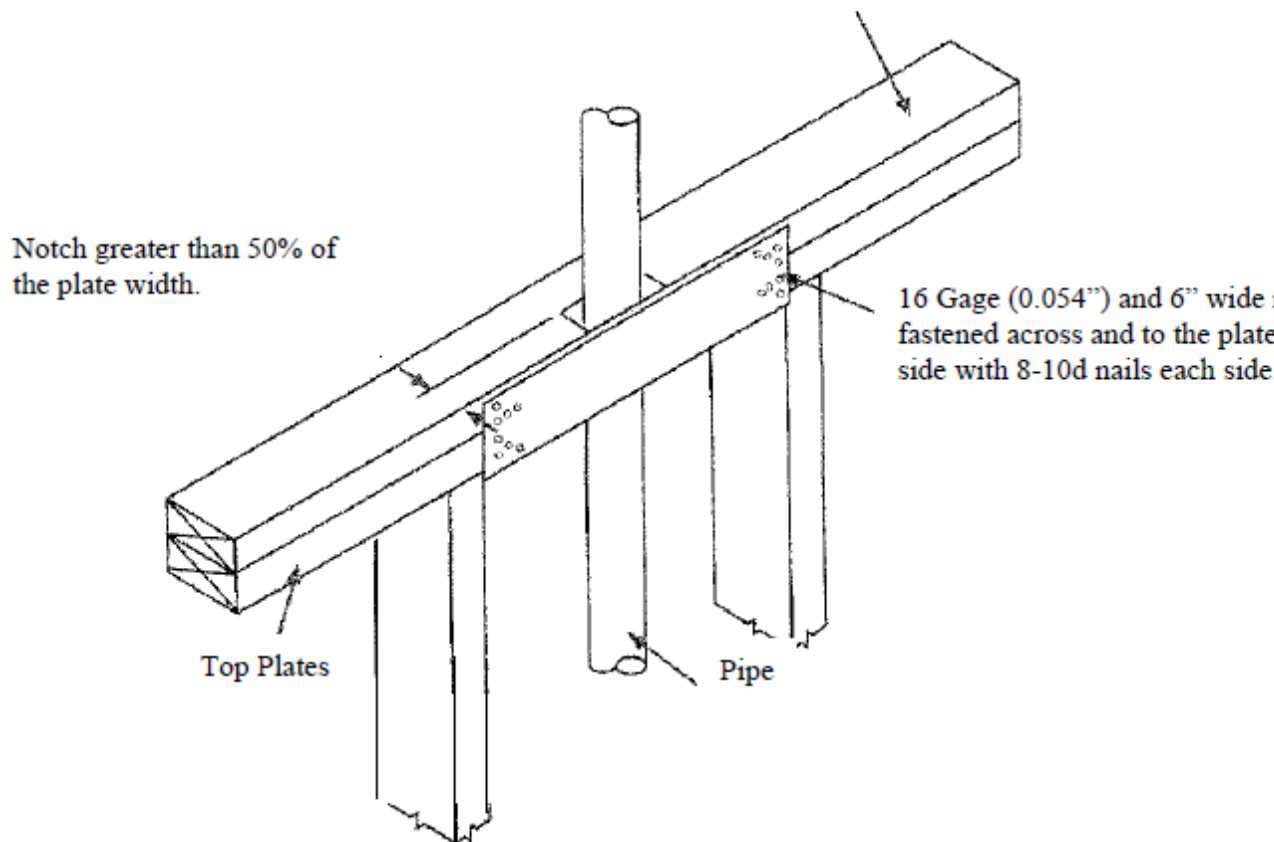

Section R703.8.4.1 shall be amended by adding a second paragraph to the end of the section to read as follows:

In stud framed exterior walls, all ties shall be anchored to studs as follows:

1. When studs are 16 inches o.c., stud ties shall be spaced no further apart than 24 inches vertically starting approximately 12 inches from the foundation; or
2. When studs are 24 inches o.c., stud ties shall be spaced no further apart than 16 inches vertically starting approximately 8 inches from the foundation.

Section R902.1 Roofing covering materials shall be amended to read as follows:

R902.1 Roofing covering materials. Roofs shall be

covered with materials as set for the in section R904 and R905. Only class A, B, C roofing shall be installed. Class A, B and C roofing requirements by this section to be listed shall be tested in accordance with UL790 or ASTM E 108.

Exceptions:

1. {Text unchanged}
2. {Text unchanged}
3. {Text unchanged}
4. {Text unchanged}
5. Nonclassified roof coverings shall be permitted on one-story detached accessory structures used as tool and storage sheds, playhouses, and similar uses, provided the floor area does not exceed 100 square feet.

Chapter 11 Energy efficiency, the contents of chapter 11 shall be deleted in their entirety and replaced with the following:

N1101 Scope. This chapter regulated the energy efficiency of the design and construction of buildings regulated by this Code.

N1101.2 Compliance. Compliance shall be demonstrated by meeting the requirement of the residential provisions of the 2015 International Energy Conservation Code as amended in conformance with State law.

Section M1305.1.3 Appliances in attics, shall be amended to read as follows:

M1305.1.3 Appliances in attics. Attics containing appliances requiring access for maintenance, repair, or replacement shall be provided with an opening and unobstructed passageway large enough to allow removal of the largest appliance. The passageway shall not be less than 30 inches high and 22 inches wide and not more than 20 feet in length measured along the centerline of the

passageway from the opening to the appliance. The passageway shall have continuous unobstructed solid flooring not less than 22 inches wide. A level service space not less than 30 inches deep and 30 inches wide shall be present at the front or service side of the appliance. The clear access opening dimensions shall be a minimum of 20 inches by 30 inches or shall be larger where such dimensions are not large enough to allow removal of the largest appliance. As a minimum, access to the attic space shall be provided by one of the following:

1. A permanent stair;
2. A pull down stair with a minimum 300 lb capacity;
3. An access door from an upper floor level;  
or
4. An access panel may be used in lieu of items 1, 2, or 3 with prior approval of the Building Official due to building conditions.

Exception: The passageway and level service space are not required where the appliance is capable of being removed through the required opening.

Section M1503.4 Makeup air required shall be amended to read as follows:

M1503.4 Makeup air required. Exhaust hood systems capable of exhausting in excess of 400 cubic feet per minute shall be provided with makeup air at a rate approximately equal to the difference between the exhaust air rate and 400 cubic feet per minute. Such makeup air systems shall be equipped with means of closure and shall be automatically controlled to start and operate simultaneously with the exhaust system.

Exception: Where all appliances in the house are of sealed combustion, power-vent, unvented, or electric, the exhaust hood system shall be permitted to exhaust up to 600 cubic feet per

minute without providing make up air. Exhaust hood system capable of exhausting in excess of 600 cubic feet per minute shall be provided with a makeup air at a rate approximately equal to the difference between the exhaust air rate and 600 cubic feet per minute.

Section M2005.2 Prohibited locations shall be amended to read as follows:

M2005.2 Prohibited locations. Fuel fired water heaters shall not be installed in a room used as a storage closet. Water heaters located in a bedroom or bathroom shall be installed in a sealed enclosure so that combustion air will not be taken from the living space. Access to such enclosure may be from the bedroom or bathroom when through a solid door, weather stripped in accordance with the exterior door air leakage requirements of the International Energy Conservation Code and equipped with an approved self-closing device. Installation of direct-vent water heaters within enclosure is not required.

Section G2408.3 shall be deleted in its entirety.

Section G2415.2.1 Identification shall be amended by adding a new subsection to read as follows:

G2415.2.1 Identification. For other than steel pipe, exposed piping shall be identified by a yellow label marked "gas" in black letters. The marking shall be spaced at intervals not exceeding 5 feet. The marking shall not be required on pipe located in the same room as the appliance served. Both ends of each section of medium pressure corrugated stainless steel tubing (CSST) shall identify its operating gas pressure with an approved tag. The tags are to be composed of aluminum or stainless steel and the following working shall be stamped into the tag:

"WARNING  
1/2 to 5 psi gas pressure  
Do Not Remove"

Section G2415.12 Minimum burial depth shall be amended to read as follows:

G2415.12 Minimum burial depth. Underground piping systems shall be installed a minimum depth of 18 inches below grade.

Section G2415.12.1 Individual outside appliances shall be deleted in its entirety.

Section G2417.4 Test pressure measurement, shall be amended to read as follows:

G2417.4 Test pressure measurement. Test pressure shall be measured with a monometer or with a pressure-measuring device designed and calibrated to read, record, or indicate a pressure loss caused by leakage during the pressure test period. The source of pressure shall be isolated before the pressure tests are made.

Section G2417.4.1 Test pressure, shall be amended to read as follows:

G2417.4.1 Test pressure. The test pressure to be used shall be no less than 3 psig (20 kPa gauge), or at the discretion of the Code Official, the piping and valves may be tested at a pressure of at least six (6) inches (152 mm) of mercury, measured with a manometer or slope gauge. For tests requiring a pressure of 3 psig, diaphragm gauges shall utilize a dial with a minimum diameter of three and one half inches (3-1/2"), a set hand, 1/10 pound incrimination and pressure range not to exceed 6 psi for tests requiring a pressure of 3 psig. For tests requiring a pressure of 10 psig, diaphragm gauges shall utilize a dial with a minimum diameter of three and one-half inches (3-1/2"), a set hand, a minimum of 2/10 pound incrimination and a pressure range not to exceed 20 psi. For welded piping, and for piping carrying gas at pressures in excess of fourteen (14) inches water column pressure (3.48 kPa) (1/2 psi) and less than 200 inches of water column pressure (52.2 kPa) (7.5 psi), the test pressure shall not be less than ten (10) pounds per square inch (69.6 kPa). For

pipng carrying gas at a pressure that exceeds 200 inches of water column (52.2 kPa) (7.5 psi), the test pressure shall be not less than one and one-half times the proposed maximum working pressure.

Section G2417.4.2 Test duration, shall be amended to read as follows:

G2417.4.2 Test duration. Test duration shall be held for a length of time satisfactory to the Code Official, but in no case for less than fifteen (15) minutes. For welded piping, and for piping carrying gas at pressures in excess of fourteen (14) inches water column pressure (3.48 kPa), the test duration shall be held for a length of time satisfactory to the Code Official, but in no case for less than thirty (30) minutes.

Section G2420.1.4 Valves in CSST installations, shall be added as a new section to read as follows:

G2420.1.4 Valves in CSST installations. Shutoff valves installed with corrugated stainless steel (CSST) piping systems shall be supported with an approved termination fitting, or equivalent support, suitable for the size of the valves, of adequate strength and quality, and located at intervals so as to prevent or damp out excessive vibration but in no case greater than 12-inches from the center of the valve. Supports shall be installed so as not to interfere with the free expansion and contraction of the system's piping, fittings, and valves between anchors. All valves and supports shall be designed and installed so they will not be disengaged by movement of the supporting piping.

Section G2421.1 Pressure regulators, shall be amended to read as follows:

G2421.1 Pressure regulators. A line pressure regulator shall be installed where the appliance is designed to operate at a lower pressure than the supply pressure. Line gas pressure regulators shall be listed as complying with ANSI Z21.80. Access shall be provided to pressure regulators.

Pressure regulators shall be protected from physical damage. Regulators installed on the exterior of the building shall be approved for outdoor installation. Access to regulators shall comply with the requirements for access to appliances as specified in section 306.

Exception: A passageway or level service space is not required when the regulator is capable of being serviced and removed through the required attic opening.

Section G2445.2 Prohibited use, shall be amended to read as follows:

G2445.2 Prohibited use. One or more unvented room heaters shall not be used as the sole source of comfort heating in a dwelling unit.

Exception: Existing approved unvented heaters may continue to be used in dwelling units, in accordance with the Code provisions in effect when installed, when approved by the Code Official unless an unsafe condition is determined to exist.

Section G2448.1.1 Installation requirements shall be amended to read as follows:

G2448.1.1 Installation requirements. The requirements for water heaters relative to access, sizing, relief valves, drain pans and scald protection shall be in accordance with this Code.

Section P2801.6.1 Pan size and drain shall be amended to read as follows:

P2801.6.1 Pan size and drain. The pan shall be not less than 1-1/2 inches (38 mm) in depth and shall be of sufficient size and shape to receive all dripping or condensate from the tank or water heater. The pan shall be drained by an indirect waste pipe having a diameter of not less than 3/4 inch (19 mm). Piping for safety pan drains shall be of those materials listed in table 605.4. Multiple pan drains may terminate to a single

discharge piping system when approved by the administrative authority and permitted by the manufactures installation instructions and installed with those instructions.

Section P2804.6.1 Requirement for discharge piping shall be amended to read as follows:

P2804.6.1 Requirements for discharge piping. The discharge piping serving a pressure relief valve, temperature relief valve or combination thereof shall:

1. Not be directly connected to the drainage system.
2. Discharge through an air gap.
3. Not be smaller than the diameter of the outlet of the valve served and shall discharge full size to the air gap.
4. Serve a single relief device and shall not connect to piping serving any other relief device or equipment.

Exception: Multiple relief devices may be installed to a single T & P discharge piping system when approved by the Building Official and permitted by the manufacture's installation instructions and installed per those instructions.

5. Discharge to an indirect waste receptor or to the outdoors. Where discharging to the outdoors in areas subject to freezing, discharge piping shall be first piped to an indirect waste receptor through an air gap located in a conditioned area.
6. Discharge in a manner that does not cause personal injury or structural damage.
7. Discharge to a termination point that is readily observable by the building occupants.

8. Not be trapped.
9. Be installed so as to flow by gravity.
10. Not terminate less than 6 inches or more than 24 inches above grade.
11. Not have a threaded connection at the end of such piping.
12. Not have valves or tee fittings.
13. Be constructed of those materials listed in section 605.4 or materials tested, rated and approved for such use in accordance with ASME A112.4.1.

Section P2902.5.3 Lawn irrigation systems shall be amended to read as follows:

P2902.5.3 Lawn irrigation systems. The potable water supply system to lawn irrigation systems shall be protected against backflow by an atmospheric type vacuum breaker, a pressure type vacuum breaker, a double-check assembly or a reduced pressure principle backflow preventer. A valve shall not be installed downstream from an atmospheric vacuum breaker. Where chemicals are introduced into the system, the potable water supply shall be protected against backflow by a reduced pressure principle backflow preventer.

Section P3003.9 Solvent cementing shall be amended by deleting the exceptions in their entirety.

Section P3112.2 Installation shall be amended to read as follows:

P3112.2 Installation. Traps for island sinks and similar equipment shall be roughed in above the floor and may be vented by extending the vent as high as possible, but not less than the drain board height and then returning it downward and connecting it to the horizontal sink drain immediately downstream from the vertical fixture drain. The return vent shall be connected to the

horizontal drain through a wye-branch fitting and shall, in addition, be provided with a foot vent taken off the vertical fixture vent by means of a wye-branch immediately below the floor and extending to the nearest partition then through the roof to the open air or may be connected to their vents at a point not less than six (6) inches above the flood level rim of the fixtures served. Drainage fittings shall be used on all parts of the vent below the floor level and a minimum slope of 1/4 inch per foot back to the drain shall be maintained. The return vent used under the drain-board shall be a one (1) piece fitting or be a forty-five (45) degree, a ninety (90) degree and a forty-five (45) elbows in the order named. Pipe sizing shall be as elsewhere required in this Code. The island sink drain, upstream of the return vent shall serve no other fixtures. An accessible cleanout shall be installed on the vertical portion of the foot vent."

#### **Section 6**

That Section 34.57, "Fees", of Chapter 34, "Planning", of the Code of Ordinances of the City of Garland, Texas, is hereby repealed.

#### **Section 7**

That Section 1.04, "Conflict in Authority", of Chapter 1, "General Provisions", of the Garland Development Code of the City of Garland, Texas, is hereby amended by adding a new Subsection (C) which shall read as follows:

#### **"Section 1.04 Conflict in Authority**

(C) Conflict with State Law. To the extent any provision of this GDC conflicts with Texas law, the provision shall be construed so as to be in compliance with state law, where possible. If it is not possible to construe a given provision in a manner that is compliant with state law, the provision shall not be enforced."

## Section 8

That Section 1.12, "Procedures of the Development Review Committee", of Chapter 1, "General Provisions", of the Garland Development Code of the City of Garland, Texas, is hereby amended to read in pertinent part as follows:

### **"Section 1.12 Procedures of the Development Review Committee**

(A) Types of Applications Reviewed. The DRC shall review the following types of applications:

- (1) An application for a Detail Plan for a Planned Development District, along with any related application requirements, including a Preliminary Development Plan and Site Engineering Drawings;

. . ."

## Section 9

That Section 1.14, "Initiation of Application", of Chapter 1, "General Provisions", of the Garland Development Code of the City of Garland, Texas, is hereby amended to read as follows:

### **"Section 1.14 Initiation of Application**

(A) Initiation by Owner. Unless otherwise expressly provided by this GDC, a development application or other petition authorized by this GDC may be initiated only in writing by, and bearing the original signature of, the actual owner of the land subject to the application, or by the owner's duly authorized representative. If the applicant is a designated representative, the application shall include a written and notarized statement from the property owner authorizing the representative to file the application on the owner's behalf. The responsible official may establish the type of documents needed to determine ownership or agency.

(B) Initiation by City. A duly authorized representative of the City may initiate any application authorized under this GDC.

(C) Development Application Fee. Unless an applicant elects to participate in the pre-submittal process, the development application fee, as set by the City Fee Schedule, shall be due at the time the applicant files the application with the Planning Director.

(D) Application Appointments. Zoning, development plan, redevelopment, detail plan, or land subdivision applications may be filed, by appointment only, with the Planning Director, upon the date and time identified in the Development Application Schedule. In the event the designated filing day falls on a City Holiday then applications may be filed, by appointment only, on the next business day on which the City is open at the time identified on the Development Application Schedule. The Planning Director may limit the number of applications filed on a particular day if the Planning Director determines that it is not administratively feasible to process any additional applications within 30 days."

## **Section 10**

That Section 1.15, "Pre-Submittal Process", of Chapter 1, "General Provisions", of the Garland Development Code of the City of Garland, Texas, is hereby amended to read as follows:

### **"Section 1.15 Pre-Submittal Process**

(A) Pre-submittal process voluntary. Prior to the official submission of a zoning, development plan, redevelopment, detail plan, or land subdivision application, the prospective applicant may elect to voluntarily participate in a pre-submittal process with the DRC and the responsible official who will primarily process the application.

(B) Purpose. The purpose of the pre-submittal process is to discuss the prospective applicant's general plans, needs, constraints and goals for the property, and to allow the prospective applicant to become familiar with the City's codes, development regulations, fees, and processes applicable to the project.

(C) Initial Pre-Submittal Meeting. A prospective applicant shall be given the opportunity to meet with the Director of

Planning and other city officials to discuss the prospective applicant's general development or redevelopment proposal. Following the initial pre-submittal meeting, the Director of Planning shall make a determination as to whether it would be beneficial for the prospective applicant to further participate in the pre-submittal process. In the event it is determined that it would be beneficial, and the prospective applicant elects to participate in the pre-submittal process, the prospective applicant shall file with the Planning Department a pre-submittal form that describes the nature of the project and the type(s) of application(s) that the applicant intends to submit. The prospective applicant shall then be notified of the time and place of the DRC Pre-Submittal Meeting where the proposed application shall be discussed.

(D) Vested Rights. Any assertion of vested rights based on working documents submitted during the pre-submittal process shall be limited to a two-year period (that is, 730 calendar days) from the original date upon which the initial pre-submittal form was filed (see Chapter 5, Article 1, Division 5).

(E) Primary Contact and Case Manager. At the DRC Pre-Submittal Meeting, a City official shall be assigned to act as the primary contact for the prospective applicant and the related proposed development application(s).

(1) The person assigned to be the primary contact will answer general questions, refer specific questions to applicable City staff, as well as coordinate any meetings between a prospective applicant and the City. The primary contact may become the Case Manager during the application review process; however, if a public hearing is a part of the process, a new Case Manager may be assigned prior to the associated technical review meeting (see Section 1.21 of this Chapter 1).

(2) When construction is ready to commence, a City official shall be assigned to act as Case Manager for the applicant for the project construction and inspection processes. The Case Manager will be assigned to the applicant at the Pre-Construction Meeting (see Section 1.22 of this Chapter 1).

(F) Written Records. Written and digital records submitted during the pre-submittal process shall be kept in the office of the Planning and Community Development as part of the record for each proposed development application or project. A copy of the written records of the pre-submittal process shall also be provided to any prospective applicant participating in the pre-submittal process upon written request by the participant.

(G) DRC Pre-Submittal Meeting; Technical Review Meeting. The purpose of the DRC Pre-Submittal Meeting is to discuss in more detail the prospective applicant's general plan and proposed development or redevelopment with the members of the DRC. Following the DRC Pre-Submittal Meeting, the prospective applicant shall pay the pre-submittal process fee, as set by the City Fee Schedule, if the prospective applicant elects to participate in the pre-submittal process. As part of the pre-submittal process, the prospective applicant may be required to attend one or more additional pre-submittal meetings and technical review meetings with the DRC, as determined necessary by the Planning Director.

(H) Effect. If the prospective applicant completes the pre-submittal process, as determined by the Planning Director, the development application fee set by the City fee schedule is waived, and the prospective applicant may proceed with his or her official submittal of a zoning, development, redevelopment or land subdivision application. In the event a prospective applicant elects to participate in the pre-submittal process, pays the required pre-submittal process fee, and thereafter does not compete the pre-submittal process, as determined by the Planning Director, prior to filing his or her official application, the prospective applicant shall not receive a refund of the pre-submittal process fee, and shall additionally pay the development application fee, in its entirety, as set by the City fee schedule, at the time of filing the application."

## **Section 11**

That Section 1.16, "Complete Application & Expiration", of Chapter 1, "General Provisions", of the Garland Development Code of the City of Garland, Texas, is hereby repealed.

## **Section 12**

That Section 1.18, "Official Submission Date", of Chapter 1, "General Provisions", of the Garland Development Code of the City of Garland, Texas, is hereby amended to read as follows:

### **"Section 1.18 Official Submission Date**

The time period established by this GDC for processing or deciding an application shall commence on the date on which the applicant submits his or her application to the Planning Director."

## **Section 13**

That Section 1.19, "Modification of Application", of Chapter 1, "General Provisions", of the Garland Development Code of the City of Garland, Texas, is hereby amended to read as follows:

### **"Section 1.19 Modification of Applications**

The applicant may modify a complete application following its submission and prior to expiration of the period during which the City is required to act on the application, if the modification is for revisions requested by the City, and is received by the Director of Planning at least seven calendar days prior to the time scheduled for decision on the application. In the event the applicant voluntarily elects to extend the period during which the City is required to act on the application, then the applicant may modify any complete application following its submission if the modification is received by the Planning Director at least seven calendar days prior to the time the applicant voluntarily elected to schedule for a decision on the application. The voluntary extension of time may not exceed a period of thirty days from the date on which the application was originally set for hearing."

## **Section 14**

That Section 1.20, "Amendments and Revisions to Approval", of Chapter 1, "General Provisions", of the Garland

Development Code of the City of Garland, Texas, is hereby amended to read as follows:

**"Section 1.20 Amendments and Revisions to Approval**

Unless another method is expressly provided by this GDC (see Section 1.19), any request to amend or revise a submitted application shall be considered a new application and must be decided in accordance with the procedures governing an original application and the standards in effect at the time such new application is filed with the City."

**Section 15**

That Section 1.21, "Technical Review Meeting", of Chapter 1, "General Provisions", of the Garland Development Code of the City of Garland, Texas, is hereby amended to read as follows:

**"Section 1.21 Technical Review Meeting**

(A) Requirement. In the event a prospective applicant elects to participate in the pre-submittal process, the prospective applicant may be required to attend one or more technical review meetings with the DRC, including the responsible official.

(B) Purpose. The purpose of a technical review meeting is to allow the prospective applicant to review his or her proposed development application files and working documents with the DRC. Comments compiled from each City department as part of their review of the files and working documents shall be provided to the prospective applicant at the meeting. The comments shall provide information about necessary modifications needed for the proposed development application to meet City codes, development regulations and processes that are applicable to the proposed application.

(C) Applications Requiring Technical Review Meeting. Pre-Submittal documents and working files that require a technical review meeting (unless otherwise determined as unnecessary by the City) include documents related to a proposed application for the following:

- (1) Specific Use Provision;

(2) Detail Plan (submitted as part of a Planned Development application);

(3) Preliminary Development Plan;

(4) Alternative compliance development process (if applicable);

(5) House conversions (such as conversion from residential to nonresidential use); or

(6) Any other proposed application as determined by the Planning Director.

(D) Effect. Following the technical review meeting with the DRC, the prospective applicant may proceed with making the necessary modifications discussed. Once all modifications have been + made and the revisions to the pre-submittal documents have been submitted to the Planning Director for review, the Planning Director shall make the determination as to whether the pre-submittal process has been completed or whether additional modifications of the proposed application are needed."

### **Section 16**

That Division Three, "Impact Fees", of Article 3, "Fees", of Chapter 1, "General Provisions", of the Garland Development Code of the City of Garland, Texas, is hereby amended by reserving Sections 1.92 - 1.99 for future amendments.

### **Section 17**

That Article 3, "Fees", of Chapter 1, "General Provisions", of the Garland Development Code of the City of Garland, Texas, is hereby amended by adding a new Division Four titled "Planning and Zoning Fees", and shall read as follows:

#### **"Division Four: Planning and Zoning Fees**

#### **Section 1.100 Fees**

The following fees shall apply to all filings, except where otherwise noted:

(A) Zoning change or specific use provision applications opting out of the presubmittal process. The following fees shall apply to applications for zoning change or specific use provision if the Applicant opts not to proceed through the pre-submittal process set forth in Section 1.15 of this GDC.

<b>Type of Application</b>	<b>Fee</b>
Planned development (PD) zoning (new or revised detail plan)	\$6,000.00 + \$50.00 per acre
Planned development - amendment of conditions	\$6,000.00
Specific use provision - new construction or expansion	\$6,000.00 + \$50.00 per acre
Specific use provision - use change	\$6,000.00
Specific use provision - residential less than one (1) acre	\$6,000.00 (0 – 1 acre)
Zoning change request	\$6,000.00
Preliminary, final, or replats	\$6,000.00 + \$50.00 acre or portion thereof
Residential replats/final plat involving residentially zoned platted property	\$6,000.00 + \$50.00 acre or portion thereof
Amending plats	\$3000.00 + \$50.00 acre or portion thereof
Minor plats	\$6,000.00 + \$50.00 acre or portion thereof
Plat vacation	\$6,000.00 + \$50.00 acre or portion thereof
Conveyance plats	\$6,000.00 + \$50.00 acre or portion thereof
Downtown development plan/regulating plan (new construction - includes major waiver)	\$6,000.00
Resubmission of any application denied due to errors in the detail plan	\$6,000.00 + \$50.00 per acre

(B) Zoning change, specific use provision, or plat applications submitted to the presubmittal procedures in Section 1.15 of this GDC.

<b>Type of Application</b>	<b>Fee</b>
Planned development (PD) zoning (new or revised concept/detail plan)	\$2,000.00 + \$50.00 per acre
Planned development - amendment of conditions	\$1,000.00
Specific use provision - new construction or expansion	\$1,000.00 + \$50.00 per acre
Specific use provision - use change	\$1,000.00
Specific use provision - residential less than one (1) acre	\$500.00 (0 – 1 acre)
Zoning change request	\$1,000.00
Preliminary, final, or replats	\$500.00 + \$50.00 acre or portion thereof
Residential replats/final plat involving residentially zoned platted property	\$500.00 + \$50.00 acre or portion thereof
Amending plats	\$250.00 + \$50.00 acre or portion thereof
Minor plats	\$500.00 + \$50.00 acre or portion thereof
Plat vacation	\$500.00 + \$50.00 acre or portion thereof
Conveyance plats	\$500.00 + \$50.00 acre or portion thereof
Downtown development plan/regulating plan (new construction - includes major waiver)	\$1,000.00

(C) Variance, appeal, waiver, and miscellaneous applications.

<b>Type of Application</b>	<b>Fee</b>
Alcohol distance	\$500.00
Alley waiver	\$300.00
Building line modification	\$150.00
Building line modification, if board of adjustment appeal is also required	None
Development standards variance (screening and landscaping, signage)	\$350.00
Alternative compliance	\$200.00
Fence variance	\$250.00

House conversion (requiring public hearing)	\$800.00
Preliminary development plan (new construction)	\$1,000.00
Preliminary development plan (special use standards)	\$100.00
Downtown minor waiver	\$250.00
Reasonable accommodations	\$0.00
Vested rights petition	\$0.00
Sidewalk waiver	\$200.00
Sign variance	\$250.00
Tree removal permit (application fee only; tree mitigation fees required as applicable)	\$150.00
Tree preservation variance	\$300.00
Municipal setting designation	\$5,000.00

(D) Zoning verification letters.

Type	Fee
Zoning verification letter	\$200.00

**Section 1.101 Refund Policy for Planning & Zoning Fees**

(A) A party which has requested one or more of the services enumerated in Section 1.100 of this GDC may request a refund of a portion of the fees paid, but only if the party withdraws the request prior to both the advertisement of legal notice or distribution of bond letters. If a party timely withdraws its request, the party is entitled to a refund of 50% of the fees actually paid. For purposes of this Section, the Director of Planning shall decide whether a party has timely withdrawn its request.

(B) A party which fails to timely withdraw its request shall not be entitled to any refund of these fees.

**Sections 1.102-1.110 Reserved."**

**Section 18**

That Section 2.04, "General Provisions", of Chapter 2, "Zoning Procedures", of the Garland Development Code of the

City of Garland, Texas, is hereby amended in its entirety to read as follows:

**"Section 2.04           General Provisions**

(A) Responsible Official. The Planning Director is the responsible official for processing an application for a change of zoning.

(B) Definitions. Following are definitions, general terms, and special terms used in this GDC that are related to the approval process for land development applications.

(1) "Plan" means a subdivision development plan, including a subdivision plan, subdivision construction plan, site plan, detail plan, land development application, and site development plan.

(2) "Plat" includes a preliminary plat, general plan, final plat, and replat.

(C) Initiation of Change of Zoning. Only the property owner or the owner's authorized representative, the Plan Commission on its own motion, or the City Council on its own motion, may initiate an application for a change of zoning on a land parcel.

(1) In the event the ownership stated on an application is different from that shown in City or appraisal district records, or if the applicant is a representative of the property owner, the applicant must submit written evidence of ownership (such as a certified copy of a deed, will, or other conveyance instrument) or a verification signed and notarized by the property owner that the applicant is acting as an authorized representative for the property owner, as applicable.

(2) A landowner or representative seeking approval of an application for a change of zoning must pay or otherwise satisfy all delinquent taxes, paving assessments, impact fees, or any other delinquent debts or obligations for the land to be rezoned before the application is submitted, in accordance with Section 1.09 in

Chapter 1 of this GDC. It is the applicant's burden to provide evidence that all taxes and obligations have been paid.

(D) Contents of Application for Change of Zoning. Detailed requirements for the format and contents of an application for change of zoning must be in accordance with requirements in the *Development Application Packet*, as may be amended from time to time."

## Section 19

That Section 2.05, "General Provisions", of Chapter 2, "Processing of Zoning Application, Plat, Plan, and Decision", of the Garland Development Code of the City of Garland, Texas, is hereby amended in its entirety to read as follows:

### **"Section 2.05            Processing of Zoning Application, Plat, Plan, and Decision**

(A) Planning Director Report. For all change of zoning requests (including a PD or SUP) or applications of a plan or plat, the Planning Director must review the application and prepare a written report providing a planning analysis on the merits of the zoning application, plan, or plat.

(1) The report shall include the proposed development's impacts, if any, on planning, engineering, transportation, building inspection, fire protection, and neighborhood enhancement and protection, depending on the issues and complexity of the development. In the event an applicant files both an application for a change in zoning and a plat or plan (including zoning applications that require a plan or plat), the Planning Director shall determine whether the plan or plat meets the requirements of state law and the GDC, and provide a separate planning analysis on the merits of the zoning case.

(2) For applications including a plan or plat, as applicable, the report must include a recommendation approving, approving with conditions, or denial of the plan or plat. In the event the recommendation of the Planning Director

is approving with conditions or a denial of the application, the Planning Director shall include in the report, in the form of a proposed order, a statement of the conditions for the conditional approval, or reasons for disapproval, that clearly articulate each specific condition for the conditional approval or reason for disapproval. Each condition or reason specified in the proposed order must:

(a) be directly related to the requirements under Chapter 212, Subchapter A of the Texas Local Government Code; and

(b) include a citation to the law, including a statute or municipal ordinance, that is the basis for the conditional approval or disapproval.

(3) The report must be submitted to the Plan Commission prior to the Commission making a recommendation to the Council, and must be submitted to the Council prior to its decision.

(B) Published and Personal Notice. For a public hearing on a change of zoning application, the Planning Director shall publish notice as set forth below:

(1) For a public hearing before the Plan Commission: personal notice in accordance with [Section 1.24\(B\)](#) in Chapter 1 of this GDC;

(2) For a public hearing before the City Council, or joint public hearing before the Plan Commission and the City Council: published and personal notice in accordance with [Sections 1.24\(A\) and 1.24\(B\)](#) in Chapter 1 of this GDC.

(C) Posted Notice. For any requested change of zoning on a specific parcel, a sign must be posted on the property, in accordance with procedures set forth in the Development Application Packet, as may be amended from time to time.

(D) Joint Public Hearing. The City Council and Plan Commission may convene a joint public hearing on a change of zoning request at the time and place designated in the public hearing notice(s). The hearing must be conducted in

accordance with the City Council's normal rules and procedures that are applicable to public hearings. The Mayor, or his designee, shall be the presiding officer at a joint public hearing where an application for a change of zoning is heard.

(E) Applicant Representation. The applicant, or an authorized representative for the applicant, must attend the public hearing held by the Plan Commission and, separately or jointly, by the City Council for the requested change of zoning. If an applicant (or duly authorized representative) does not appear at such public hearing, then such absence may constitute sufficient grounds for the change of zoning application to be postponed or denied.

(F) Plan Commission - Public Hearing & Recommendation.

(1) The Plan Commission shall hold a public hearing to consider a proposed change of zoning. Following the public hearing, the Plan Commission shall provide its recommendation on the requested change of zoning, and shall forward its recommendation to the City Council. The Plan Commission may recommend approval or denial of the change of zoning application.

(2) In cases where the applicant is requesting both a change of zoning and an approval of a plan or plat, the Plan Commission shall

(a) determine whether the plan or plat meets the requirements of state law and the GDC,

(b) provide a separate planning analysis on the merits of the zoning and land use, and

(c) make separate recommendations for the zoning request and the plan in the form of a proposed order to City Council.

(3) Mandatory Approval. The Plan Commission shall recommend approval of a plan or plat that is required to be prepared under this GDC or state law and that satisfies all applicable regulations.

(4) Underlying Zoning. A plan does not meet technical requirements if the intended use is not consistent with the underlying zoning. In cases where the applicant is requesting both a change of zoning and an approval of a plan, the Plan Commission shall recommend denial of the plan if the Plan Commission also recommends a denial for the request for a zoning change and the intended use is inconsistent with the current zoning designation.

(5) Recommendation Deadline on a Plan. The Plan Commission shall recommend approval, approval with conditions, or disapproval of a plan within 30 days after the date the plan is filed. In the event the Plan Commission fails act on a plan within 30 days, the plan shall be considered favorably recommended by the Plan Commission and the proposed order to the City Council shall reflect that the plan is recommended by the plan Commission by inaction.

(6) Decision Deadline on a Plat. The Plan Commission shall approve, approve with conditions, or disapprove a plat within 30 days after date the plat is filed. A plat shall be considered approved by the Plan Commission unless it is disapproved within the 30 day period.

(7) Proposed Order. Following the public hearing, the Plan Commission shall issue a proposed written order to the City Council stating its decision to approve, approve with conditions, or disapprove a plan. In cases where the applicant is requesting a zoning change, the proposed order shall provide a separate planning analysis on the merits of the zoning and land use. The applicant shall be given a copy of the proposed order.

(8) Conditional Approval or Denial of a Plan. If the Plan Commission recommends a conditional approval or disapproval of a plan, the proposed order shall state the conditions for the

conditional approval or reasons for disapproval that clearly articulates each specific condition for the conditional approval or reason for disapproval. Each condition or reason specified in the written statement must:

(a) be directly related to the requirements under Chapter 212, Subchapter A, of the Texas Local Government Code; and

(b) include a citation to the law, statute, or ordinance, that is the basis for the conditional approval or disapproval.

(9) Postponement of Decision. The Plan Commission may, by written request of the applicant, postpone making a decision on the application of a plan or plat and may defer its recommendation to City Council. Upon approval of the Plan Commission, the postponement may be for a period not to exceed 30 calendar days, and does not require additional public notice if such postponement is to a date certain. The Plan Commission may not request or require an applicant to request postponement, waive a deadline or other approval procedure under this GDC or Chapter 212, Subchapter A of the Texas Local Government Code.

(10) The Plan Commission may recommend approval of a zoning designation of lesser intensity within the same general zoning category (such as residential, nonresidential, or mixed-use, see [Table 2-1](#)) without additional public notice provided that the impact on adjacent properties would be lessened or not affected (that is, the lesser intensity would have no anticipated harmful effect on adjacent properties).

(11) The Plan Commission may recommend approval of a modified version of the requested zoning district (or of a less intense district) in the form of a Planned Development (PD) District

(refer to [Article 2, Division 2](#) of this Chapter 2).

(G) City Council - Public Hearing & Decision.

(1) Following receipt of the Plan Commission's recommendation, the Planning Director Report, and a public hearing on the change of zoning request, the City Council shall consider the request for a change of zoning, and render a decision on the request. The City Council may approve or deny the request. The Council's decision on a change of zoning request is final.

(2) The City Council may decide the change of zoning request based upon the Plan Commission's recommendation, or:

(a) It may approve a zoning designation of lesser intensity within the same general zoning category (such as residential, nonresidential, mixed-use, etc. - see [Table 2-1](#)) provided that the impact on adjacent properties would be lessened or not affected (that is, the zoning designation of lesser intensity would have no anticipated harmful effect on adjacent properties).

(b) It may approve a modified version of the requested zoning change (or of a less intense district) in the form of a Planned Development (PD) District (refer to [Article 2, Division 2](#) of this Chapter 2).

(3) In cases where the applicant is requesting both a change of zoning and an approval of a plan, the City Council shall:

(a) determine whether the plan meets the requirements of state law and the GDC,

(b) conduct a separate planning analysis on the merits of the zoning and land use, and

(c) make separate findings for the zoning request and the plan in the form of a final order.

(4) Mandatory Approval. The City Council shall approve a plan that is required to be prepared under this GDC or state law and that satisfies all applicable regulations.

(5) Underlying Zoning. A plan does not meet technical requirements if the intended use is not consistent with the underlying zoning. In cases where the applicant is requesting both a change of zoning and an approval of a plan, the City Council shall deny the plan if the request for a zoning change is denied and the intended use is inconsistent with the current zoning designation.

(6) Decision Deadline on a Plan. The City Council shall approve, approve with conditions, or disapprove a plan within 30 days after date the Plan Commission made its recommendation regarding the plan. A plan shall be considered approved by the City Council unless it is disapproved within the 30 day period. In the event the City Council fails to act on a plan within the 30 days, the plan shall be considered approved by the City Council and the final order shall state the date the plan was filed and that the City Council failed to act on the plan within the mandatory 30 day period.

(7) Conditional Approval or Denial of a Plan. In the event the City Council is approving a plan with conditions or is denying the plan, the City Council shall include in the final order a statement of the conditions for the conditional approval, or reasons for disapproval, that clearly articulate each specific condition for the conditional approval or reason for disapproval. Each condition or reason specified in the final order must:

(a) be directly related to the requirements under Chapter 212, Subchapter A of the Texas Local Government Code; and

(b) include a citation to the law, including a statute or municipal ordinance, that is the basis for the conditional approval or disapproval.

(8) Final Order. The City Council shall issue a final order indicating whether the plan was approved, approved with conditions, or denied. The final order must be signed by the Mayor and attested by the City Secretary, or a majority of the members of City Council. A written copy of the final order shall be sent to the applicant. In cases where the applicant is requesting a zoning change, the final order shall provide a separate decision of the zoning and land use request.

(9) Postponement of Decision. The City Council may, by written request of the applicant, postpone making a decision on the application of a plan or plat and may defer its final decision. The City Council may not request or require an applicant to request postponement, waive a deadline or other approval procedure under this GDC or Chapter 212, Subchapter A of the Texas Local Government Code. Upon approval of the City Council, the postponement may be for a period not to exceed 30 calendar days, and does not require additional public notice if such postponement is to a date certain.

. . .

(K) Consideration of Previously Denied Amendments. A request to change the zoning designation for a tract of land may not be considered by the Plan Commission or the City Council within one year of the Council's denial of the same, or substantially similar, requested change for all or any portion of the parcel, unless:

(1) the Council determines that there has been a substantial change in conditions surrounding the land since the initial request, and agrees to reconsider the change by a three-fourths vote of the members present and voting; or

(2) the Council's initial decision on the request to change the zoning designation was made "without prejudice."

## Section 20

That Section 2.07, "Purpose, Applicability, Nature and Size of District", of Chapter 2, "Processing of Zoning Application, Plat, Plan, and Decision", of the Garland Development Code of the City of Garland, Texas, is hereby amended in pertinent part to read as follows:

### **"Section 2.07 Purpose, Applicability, Nature and Size of District**

(A) Purpose. The purpose of a Planned Development zoning district (PD district) is to provide for the development of land as an integral unit for single or mixed uses in accordance with special conditions or a Detail Plan that may include uses, regulations and other requirements that vary from the provisions of other zoning districts. PD districts are generally intended to encourage flexible and creative planning, to ensure the compatibility of land uses, to allow for the adjustment of changing demands to meet the current needs of the community, and to result in a higher quality development for the community than would result from the use of standard zoning districts.

. . .

(C) Nature of the District. Each PD district is based on the standard zoning district(s) that most closely resembles the development anticipated. Development in a PD district must be consistent with the Detail Plan (where required) submitted in the application for a Planned Development."

## Section 21

That Section 2.08, "Authorized Uses; Consistency with Concept/Detail Plan" of Chapter 2, "Zoning Procedures", of the Garland Development Code of the City of Garland, Texas,

is hereby renamed and amended in pertinent part to read as follows:

**"Section 2.08            Authorized Uses; Consistency with Detail Plan**

. . . .

(D) Consistency Required. All development applications within a PD district must be consistent with the Detail Plan. Failure of a subsequent development application to generally conform to the approved Detail Plan will result in denial of the application, unless the PD district regulations are amended through incorporation of a revised Detail Plan with which the development application is consistent."

**Section 22**

That Section 2.11, "Concept Plan" of Chapter 2, "Zoning Procedures", of the Garland Development Code of the City of Garland, Texas, is hereby repealed.

**Section 23**

That Section 2.129, "Detail Plan" of Chapter 2, "Zoning Procedures", of the Garland Development Code of the City of Garland, Texas, is hereby amended in pertinent part to read as follows:

**"Section 2.12            Detail Plan**

. . . .

(C) Contents of Detail Plan. Detailed requirements for the format and contents of a Detail Plan must be in accordance with requirements in the *Development Application Packet*, as may be amended from time to time. The Detail Plan shall be incorporated into the regulations of the PD ordinance, shall be construed in conjunction with the authorized uses and development standards set forth in such regulations."

**Section 24**

That Section 2.13, "Approval of a Planned Development

District" of Chapter 2, "Zoning Procedures", of the Garland Development Code of the City of Garland, Texas, is hereby amended in pertinent part to read as follows:

**"Section 2.13 Approval of a Planned Development District**

. . .

(B) Approval Process. The establishment of a PD district is a change of zoning; therefore, the approval process for a PD district ordinance, including the approval of related applications such as a Detail Plan, must follow the process set forth for a change of zoning in Article 2, Division 1 of this Chapter 2.

(C) Conditions. The Plan Commission and City Council may impose such conditions to the PD district regulations and Detail Plan (as applicable) as are necessary to assure that the purpose of the PD district is implemented and to safeguard the public health, safety, and welfare."

**Section 25**

That Section 2.14, "Adopting Ordinance" of Chapter 2, "Zoning Procedures", of the Garland Development Code of the City of Garland, Texas, is hereby amended in pertinent part to read as follows:

**"Section 2.14 Adopting Ordinance**

Items Specific to the Ordinance. The ordinance establishing a PD district shall incorporate the approved Detail Plan (as applicable) as part of the district regulations and shall set forth the following:

. . ."

**Section 26**

That Section 2.39, "MF, Multifamily District" of Chapter 2, "Zoning Procedures", of the Garland Development Code of the City of Garland, Texas, is hereby amended in pertinent part to read as follows:

**"Section 2.39 MF, Multifamily District**

. . .

(H) Exterior Construction.

. . .

(2) Roofscapes

(a) Roofing Materials. Roofing materials on a MF Structure must comply with the provisions of Article 6 of Chapter 4 of this GDC.

. . ."

## Section 27

That Section 2.49, "U, Urban Districts (UR and UB)" of Chapter 2, "Zoning Procedures", of the Garland Development Code of the City of Garland, Texas, is hereby amended in pertinent part to read as follows:

### "Section 2.49 U, Urban Districts (UR and UB)

(D) Parking

. . .

(6) Structured (Garage) Parking. To enhance the overall visual character of an Urban district, and to mitigate overall bulk appearance of parking structures, the following design standards apply to parking structures in an Urban district:

(a) All above-grade parking structures must be designed to be consistent with and complementary to the architectural style of the main building(s), and must incorporate at least two of the following design elements:

i. Distinctive architectural elements (cornices, piers, columns, friezes, quoins, mullions, fenestration,

pilasters, rustication, or accentuating belt courses - see Illustration 2-8);

ii. Variation in wall planes (wall openings, canopies, articulations, wall convexities and/or concavities, balconies, or awnings - see Illustration 2-8);

iii. Change in materials (defined as a minimum of two separate, compatible materials excluding glazing - each separate material must be at least twenty percent of each facade's surface area, excluding glazing);

iv. Change in colors (defined as a minimum of two separate, compatible colors excluding glazing - each separate color must be at least twenty percent of each facade's surface area, excluding glazing).

(b) All above-grade parking structures must be designed with a distinguishable first floor, upper facades, and roofs. Parking garage first floors must be designed at human scale with pedestrian-scale elements such as awnings, canopies, window breaks, and door openings.

(c) Above-grade parking garages may be designed using decorative metal elements such as ornate meshes, screens and the like, but non-decorative steel guard cables that are visible to the public or to adjacent properties are prohibited.

(7) Individual Residential Garages and Driveways.

(a) Individual residential garages and driveways in an Urban district must be designed, constructed, and operated to allow access only from a rear (or side) alley or an interior common access service drive aisle, a dedicated fire lane, or a dedicated

shared parking court (and may not be facing or accessed from a public street).

(b) Garages in an Urban district must be set back from any street or alley right-of-way a minimum of twenty feet;

(c) Driveways for residential dwelling units must be no wider than twelve feet until the driveway is beyond the adjacent front building face.

. . . .

(H) Building/Architectural Design.

(1) Purpose. The intent of architectural design controls in Urban districts is to promote distinctive, high-quality architectural design in a pedestrian-scale setting that sets a particular Urban development apart visually (and thematically) from other developments in the vicinity. The development standards provided in this Section are intended to promote continuity among redevelopment projects and new structures within a particular Urban district.

(2) Compatibility. Exterior construction in an Urban district must be compatible and complementary as to design and colors throughout each development.

(3) Uniformity. All buildings must employ "four-sided architecture" in an Urban district, meaning that comparable design elements must be used on all exposed sides of a building. No lesser quality design elements may be used in an Urban district for the rear or any side of a building unless the side is screened from ground level view.

(4) Articulation. Architectural features of buildings in an Urban district must provide diversity and articulation of wall surfaces through use of one or more of the following architectural elements: pilasters, quoins, projected awnings, solid canopies, bay windows,

or towers. Additional horizontal and vertical building articulation requirements of an Urban district are as follows:

. . . .

(5) Facades and Building Forms. an identifiable first floor, upper facade, and rooflines. First floor facades must be designed Building facades that are visible to a public street in an Urban district must be designed with at human scale with elements such as window bays, recessed entries, awnings, canopies, and other human-scale architectural features. Additional building facade and form requirements for Urban districts are as follows:

. . . .

(f) To emphasize the pedestrian scale, building facades must incorporate the following elements:

i. Architectural elements such as cornices, piers, columns, friezes, quoins, mullions, fenestration, pilasters, rustication, or belt courses.

ii. Variations in wall planes with canopies, balconies, or awnings.

iii. Changes in materials or color - each facade must incorporate at least two separate materials or color changes, excluding glazing. Each separate material or color change must comprise at least twenty percent of each facade's appearance, excluding glazing.

(6) Highly Reflective Exterior Construction Materials.

Highly reflective materials and surfaces, including reflective metal siding and mirrored glass glazing, must be installed in such a manner

as to diffuse reflective light and prevent the focused redirection of sunlight or other luminants beyond the boundary line of the premises on which the facility is located.

(7) Exterior Colors.

(a) The use of florescent paint and florescent colors are prohibited in an Urban district.

(b) Exterior colors must complement one another, and must promote the architectural style of the Urban district.

(8) Building Entries.

(a) Main building entrances in an Urban district must be from public sidewalks or plazas and comply with the following:

i. In order to create a pedestrian-oriented and access-friendly environment, a building must have its main entrance from a public sidewalk or plaza or from a private sidewalk or plaza that is publicly accessible through a public easement.

ii. Secondary entrances to a building from a parking lot are permitted.

iii. Main entrances to a building must be easily identifiable and must utilize pedestrian-scale design elements.

(b) Building entrances in an Urban district must be accented by architectural elements such as recessed facades, columns, overhanging roofs, awnings, or balconies.

(c) Spaces in an Urban district that are along pedestrian walkways and parking lots must provide rear entrances to buildings that are identifiable with elements such as signage, plantings, awnings above rear windows, or other human-scale elements.

(d) Residential Entries. Street-level dwelling units within multi-unit structures in an Urban district must have individual street-oriented or common corridor entries. The fronts of all townhouse, row home or other single-family attached dwelling units shall face an adjacent open space, park or street.

(9) Roofs.

(a) Roof lines in an Urban district must be consistent with the coordinated architectural theme and variable in terms of shape, pitch, and height, in order to avoid long expanses of flat similar roof lines.

(b) Roofs in an Urban district must be designed as individual design elements, and must be utilized to screen roof-mounted mechanical equipment and satellite dishes.

(c) The use of mansard or gambrel roofs is prohibited in an Urban district.

(I) Site Design.

. . . .

(8) Site Furnishings. Site furnishings in an Urban district development must comply with the following:

(a) Site furnishings, including (but not limited to) benches, litter receptacles, planters, bollards, lighting, bicycle racks, public art, and fountains in an Urban district must emphasize the architectural character of each individual Urban development.

(b) Individual Urban developments must maintain continuity in the style, forms, materials, and colors of site furnishings. Site furnishings must be of the same architectural character as the buildings in

the development.

(c) Site furnishings must be durable, low-maintenance, and resistant to vandalism.

(d) Site furnishings must be placed so as to maintain an unencumbered walkway of at least four feet in width for pedestrians.

(e) Lighting for off-street parking facilities and pedestrian corridors must be of the same height, style, and color. Lighting must complement the architectural style and character of the buildings in the development."

## **Section 28**

That Section 2.52, "Special Standards for Certain Uses", of Chapter 2, "Zoning Procedures", of the Garland Development Code of the City of Garland, Texas, is hereby amended in pertinent part to read as follows:

### **"Section 2.52 Special Standards for Certain Uses**

(A) Specific Requirements. The City has established the following standards for certain land uses that apply to the uses regardless of the zoning district in which they are located, unless otherwise stated within other sections of this GDC. The definitions for each land use listed below are contained within Chapter 6 of this GDC.

. . .

(11) Hotels/Motels and Transient Lodging. All types of transient lodging, including Full Service Hotels and Motels, Extended Stay Hotels and Motels, and Limited Service Hotels and Motels must comply with the following minimum required standards and regulations in this Subsection (11):

. . .

(b) Bed and Breakfast. A Bed and Breakfast must comply with the following provisions:

. . .

(ii) Building Elements. Bed and Breakfast buildings must be designed in compliance with the requirements of the zoning district within which the building is located, as provided in Chapter 4, Article 6 of this GDC. In addition, all facades must be designed with architectural style and building materials consistent with the front facade, and a minimum of four elements from the following list must be incorporated into all Bed and Breakfast buildings (a Bed and Breakfast operating in a residential house is exempt from this Subsection):

- a. Awnings;
- b. Canopies;
- c. Ornamental cornices;
- d. Alcoves;
- e. Recessed entries;
- f. Pillar posts;
- g. Decorative lighting; or
- h. Other building elements that contribute to the architectural character of the building.

. . .

(12) Elder Care Living Facilities. Elder care living facilities, of any type, must comply with the following provisions of this Subsection (12):

. . .

(e) Site Design.

. . .

(v) Parking and Circulation.

a. A minimum of fifty percent of the required parking spaces for an independent senior living facility must be contained in either an enclosed garage or a multi-car covered parking structure. Detached covered parking must function unobtrusively and be compatible with the main buildings of the facility in regard to design, style, and color. Detached covered parking structures, if used, must be located near the building served. A detached covered parking structure may not accommodate more than ten parking spaces or be located closer than twenty feet to another parking structure.

b. All parking spaces located between any building and the right-of-way of any public street or a single-family district must be screened from view in compliance with Section 4.44, Article 3 in Chapter 4 of this GDC.

. . ."

**Section 29**

That Section 2.58, "Accessory Building Regulations" of Chapter 2, "Zoning Procedures", of the Garland Development Code of the City of Garland, Texas, is hereby amended in pertinent part to read as follows:

**"Section 2.58 Accessory Building Regulations**

. . .

(H) Accessory Building Exceeding 200 Square Feet. An Accessory building that exceeds two hundred square feet in floor area must comply with the following provisions:

(1) The height of an accessory building having more than two hundred square feet in floor area may not exceed fifteen feet, with a maximum wall height of ten and one-half feet measured from the finished floor to the top plate.

(I) Accessory Building Exceeding 500 Square Feet. An Accessory building that exceeds five hundred square feet in total floor area must comply with the following provisions:

(1) The height of an accessory building having more than five hundred square feet in floor area may not exceed twenty-five feet or the height of the main structure, whichever is less, with a maximum wall height of twelve and one-half feet measured from the finished floor to the top plate.

. . . ."

### Section 30

That Section 2.59, "Carports, Canopies and Porte Cocheres - Residential", of Chapter 2, "Zoning Procedures", of the Garland Development Code of the City of Garland, Texas, is hereby amended to read as follows:

#### **"Section 2.59 Carports, Canopies and Porte Cocheres - Residential**

(A) Carports. Residential carports, canopies, and porte cocheres must comply with the following provisions:

(1) No carports, canopies, or porte cocheres of metal construction may be located in front of a single-family residence or within a side yard adjacent to a street.

(2) Carports, canopies, or porte cocheres that are located in front of a single-family residence or within a side yard adjacent to a street shall be constructed in a manner architecturally

compatible with the main building and shall not exceed the height of the main building.

(3) Carports, canopies, or porte cocheres of metal construction may be located at the rear of a single-family residence so long as access is from a paved alley at the rear of the property.

(4) A carport, canopy, or porte cochere that is located in the rear yard of a one-story single-family residence is restricted to a height not to exceed the height of the peak of the roof of the residence or fifteen feet, whichever is greater. A carport, canopy, or porte cochere that is located in the rear yard of a two-story (or greater) single-family residence is restricted to a height of fifteen feet.

(5) All construction plans submitted for permit approval must meet applicable load span specifications required by the Building Code or bear the stamp of an Engineer licensed in the State of Texas.

(6) Carports, canopies, or porte cocheres may not be enclosed or converted into a garage space, living space, storage, or work room.

(7) The siding of carports, canopies, or porte cocheres may extend down a maximum of two feet from the roof on the open sides of the structure.

(8) These requirements apply only to carports, canopies, and porte cocheres constructed after the original effective date of the adopting Ordinance No. 5993, April 18, 2006.

(9) Carports, canopies, and porte cocheres located in multifamily developments (including senior living facilities) must comply with the below Section 2.60.

(B) Exemption. This Section 2.59 does not apply to farm or agricultural buildings."

### Section 31

That Section 2.60, "Carports, Canopies and Porte Cocheres - Nonresidential" of Chapter 2, "Zoning Procedures", of the Garland Development Code of the City of Garland, Texas, is hereby amended in pertinent part to read as follows:

**"Section 2.60 Carports, Canopies and Porte Cocheres - Nonresidential**

(A) Carports, Canopies and Porte Cocheres. A carport, canopy or porte cochere for a nonresidential use (regardless of zoning district) must:

- (1) Not encroach into a required front, side or rear yard setback;
- (2) Not extend over a public street, a City easement (unless approved by the Director of Engineering), or a refuse or solid waste container (dumpster);
- (3) Have a minimum fourteen-foot clearance when extending over a fire lane or vehicular drive aisle;
- (4) Be supported by columns that are architecturally integrated and are similar to the colors of the main building;

. . . ."

**Section 32**

That Section 3.05, "Relationship between Platting & Zoning" of Chapter 3, "Subdivision Regulations", of the Garland Development Code of the City of Garland, Texas, is hereby amended in pertinent part to read as follows:

**Section 3.05 Relationship Between Platting & Zoning**

(A) Zoning. Inside the corporate limits of the City, the following shall apply:

. . . .

- (3) Planned Development (PD) District and Specific Use

Provision (SUP) Zoning. In a Planned Development (PD) district (refer to Chapter 2, Article 2, Division 2) or for Specific Use Provision (SUP) zoning (refer to Chapter 2, Article 2, Division 3), a plat application must conform with all PD/SUP and other applicable zoning regulations, and with the approved PD/SUP zoning exhibit, Detail Plan, Site Plan, or other layout plan approved as part of the PD/SUP ordinance."

### **Section 33**

That Section 3.39, "Replat Without Plat Vacation" of Chapter 3, "Subdivision Regulations", of the Garland Development Code of the City of Garland, Texas, is hereby amended in pertinent part to read as follows:

#### **"Section 3.39 Replat Without Plat Vacation**

. . . .

#### **(D) General Notice and Hearing Requirements.**

(1) Published and personal notice is required only for certain residential Replats, in accordance with Section 212.015 of the Texas Local Government Code, as amended.

(2) For applications for replat filed on or after September 1, 2019, if a proposed replat does not require a variance or exception, no hearing shall be required. The City shall provide written notice by mail of the approval of the replat to each owner of a lot in the original subdivision that is within 200 feet of the lots to be replatted according to the most recent municipal or, in the case of subdivisions within the City's ETJ, county tax roll. The notice shall include the zoning designation of the property after the replat, and a telephone number and email address an owner of a lot may use to contact the City about the replat.

(3) For applications for replat filed on or after September 1, 2019, if a proposed replat requires either a variance or an exception, then a public hearing on a Replat shall be conducted by the

Plan Commission in accordance with the normal rules and procedures that are applicable to public hearings.

(4) For applications for replat filed before September 1, 2019, the Plan Commission shall conduct a public hearing on the replat in accordance with the normal rules and procedures applicable to public hearings.

(E) Special Residential Replat Requirements.

(1) Applicability. In addition to compliance with other requirements of this Section 3.39, a Replat without vacating the preceding plat shall conform to the requirements of this Subsection if:

(a) During the preceding five years, any of the area to be replatted was limited by an interim or permanent zoning classification to residential use for not more than two residential units per lot; or

(b) Any lot in the preceding plat was limited by deed restrictions to residential use for not more than two residential units per lot.

(2) Exception. The requirements of this Subsection do not apply to the approval of a Replat application that affects only a portion of a recorded plat if all of the proposed area sought to be replatted was designated or reserved for usage other than for single- or two-family (such as a duplex) residential use. Such designation shall be noted on the recorded plat or in the legally recorded restriction applicable to such plat.

(3) Notice and Hearing. Beginning on September 1, 2019, for any replat for which a hearing must be held pursuant to subsection (D) above, notice of the public hearing at which the Replat will be considered shall be given in accordance with Article 2, Division 2 of Chapter 1 of this GDC, unless otherwise required by state law. Prior to September 1, 2019, notice of the public hearing

at which the Replat will be considered shall be given in accordance with Article 2, Division 2 of Chapter 1 of this GDC, unless otherwise required by state law.

(4) Protest. If the Replat application is protested in accordance with this Subsection, approval of the Replat requires the affirmative vote of at least three-fourths of the members of the Plan Commission present at the meeting. For a legal protest, written instruments signed by the owners of at least twenty percent of the area of the lots or land immediately adjoining the area covered by the Replat application and extending two hundred feet from that area, but within the original subdivision, shall be filed with the Plan Commission prior to the close of the public hearing. The area of streets and alleys shall be included in the area computations.

. . ."

#### **Section 34**

That Section 4.05, "Purpose & Applicability", of Chapter 4, "Site Development", of the Garland Development Code of the City of Garland, Texas, is hereby amended to read as follows:

#### **"Section 4.05 Purpose & Applicability**

(A) Purpose. This division establishes a provision for alternative compliance associated with the review and approval of a development or redevelopment project, including improvements to existing on-site structures or existing site features, as required in Subsection (B) below. The purpose of the alternative compliance process is to ensure that:

(1) A proposed project is in compliance with this GDC to the greatest extent appropriate for the improvements to be undertaken.

(2) A proposed project meets requirements that are appropriate for lots or sites and site-specific development or redevelopment challenges

by applying a flexible approval procedure.

(3) A proposed redevelopment or development project enhances the site, and therefore the overall environment of the City.

(4) Allows for different standards that are in agreement with the City's adopted *Comprehensive Plan* and produce an equal or enhanced level of results as intended by the original development standards.

(B) Applicability.

(1) A request for alternative compliance from certain provisions as specifically cited within this GDC may be submitted for review and approval along with the Preliminary Development Plan for a project, or along with the project's initial development application (as applicable for the project). All alternative compliance requests must be clearly delineated graphically or in narrative format on the Preliminary Development Plan (or on the project's initial development application), including a reference to the specific Section within this GDC that allows consideration of alternative standard(s).

(2) The applicable zoning district standards for a project are not to be reduced or varied using the alternative compliance process unless standard is specifically cited as qualifying for alternative compliance consideration in its respective section of this GDC.

(C) Responsible Official. The Planning Director is the official responsible for processing a request for alternative compliance consideration.

(D) Development agreement required. The Planning Director may only grant a request for alternative compliance with the provisions of Articles 2, 3, or 4 of Chapter 4 of this GDC by entering into a development agreement with the applicant. The development agreement may include matters outside of Articles 2, 3, or 4 of Chapter 4 of this GDC."

### Section 35

That Section 4.52, "Administrative Approval of Alternate Compliance", of Chapter 4, "Site Development", of the Garland Development Code of the City of Garland, Texas, is hereby amended in pertinent part to read as follows:

#### **"Section 4.52 Administrative Approval of Alternative Compliance**

(A) Request for Alternative Compliance. A request for alternative compliance may be submitted in accordance with Article 1, Division 2 of this Chapter 4. The Planning Director may, by entering into a development agreement with the applicant, approve the following alternatives, but only upon a finding that the proposed alternative is; (i) consistent with the purpose and intent of this Article 3, as applicable; and (ii) promotes the public health, safety, morals, or general welfare:

. . .

(C) Development agreement required. The Planning Director may only approve a request for alternative compliance with the provisions of this Article 3 by entering into a development agreement with the applicant. The development agreement may include matters outside of this Article 3."

### Section 36

That Section 4.61, "Administrative Approval of Alternate Compliance", of Chapter 4, "Site Development", of the Garland Development Code of the City of Garland, Texas, is hereby amended in pertinent part to read as follows:

#### **"Section 4.61 Administrative Approval of Alternative Compliance**

Request for Alternative Compliance. A request for alternative compliance may be submitted in accordance with Article 1, Division 2 of this Chapter 4. The Planning Director may, by entering into a development agreement with the applicant, approve the following, but only upon a finding the proposed alternative is; (i) consistent with the purpose and intent of this Article 4, as applicable; and (ii) promotes the public health, safety, morals, or

general welfare:

. . .

(D) In order to preserve the sizes and species of significant trees that are located within a proposed parking area, the Planning Director may approve a reduction, of not more than ten percent, of the number of required parking spaces for a site, provided the applicant demonstrates adequate parking through "best practices" industry parking information.

(E) Development agreement required. The Planning Director may only approve a request for alternative compliance with the provisions of this Article 4 by entering into a development agreement with the applicant. The development agreement may include matters outside of this Article 4."

### **Section 37**

That Section 4.24, "Multifamily Developments", of Chapter 4, "Site Development", of the Garland Development Code of the City of Garland, Texas, is hereby amended in pertinent part to read as follows:

#### **"Section 4.24 Multifamily Developments**

. . .

(C) Detached Covered Parking Structures. Detached covered parking structures, if used, must:

(1) Meet the building materials and design requirements set forth in Section 2.60 in Chapter 2 of this GDC; and

(2) Be located within one hundred feet of the building served.

. . ."

### **Section 38**

That Section 4.45, "Design & Screening of Refuse Containers", of Chapter 4, "Site Development", of the

Garland Development Code of the City of Garland, Texas, is hereby amended in its entirety to read as follows:

**"Section 4.45 Design & Screening of Refuse Containers**

. . . .

(B) Compatibility. The exterior composition of screening walls must be architecturally compatible with the main building(s) and be composed of masonry materials (which must match the masonry materials used in the construction of the main building, if applicable).

. . . ."

**Section 39**

That Section 4.82, "Documentation of PD Districts," of Chapter 4, "Site Development", of the Garland Development Code of the City of Garland, Texas, is hereby renamed and amended in its entirety to read as follows:

**"Section 4.82 Purpose, Applicability; Allowable Materials**

(A) Purpose. It is the purpose of this Article 6 to provide regulations which ensure that buildings and structures in Garland are appropriately designed to create an aesthetically pleasing, quality environment.

(B) Applicability.

(1) The requirements contained within this Article 6 are minimum standards and apply to all new residential and nonresidential buildings and structures, as specified, within the City of Garland.

(3) Existing buildings and sites that are being expanded or redeveloped may be eligible to request exterior construction alternatives through the alternative compliance process as set forth in Section 4.85 of this Article 6, and in Article 1, Division 2 of this Chapter 4.

(C) Allowable materials. Buildings may be constructed

of any material approved for a given usage in a Relevant Model Code."

#### **Section 40**

That Section 4.83, "Nonresidential & Multifamily Building Materials & Design", of Chapter 4, "Site Development", of the Garland Development Code of the City of Garland, Texas, is hereby renamed and amended in pertinent part to read as follows:

#### **"Section 4.83 Nonresidential & Multifamily Building Design**

##### (A) Architectural Elements.

(1) Except as provided for Industrial (IN) districts in Subsections 4.83(G) and 4.83(H) below, all nonresidential and multifamily buildings must incorporate design elements which create character or reflect regional architecture by including at least six of the following elements, photos and examples of which are provided below:

- (a) Awnings or canopies;
- (b) Display windows;
- (c) Divided light windows;
- (d) Transoms;
- (e) Shutters;
- (f) Alcoves/porticos;
- (g) Recessed entries;
- (h) Ornamental window headers/lintels;
- (i) Quoins;
- (j) Distinctive lighting features;
- (k) Planters or fountains;

- (l) Benches for outdoor seating;
- (m) Dormers;
- (n) Varied roof heights;
- (o) Ornamental facade trims;
- (p) Bay windows; and
- (q) Gable windows.

. . . .

(B) Facade Articulation.

(1) Horizontal building articulation (facade depth) and vertical building articulation (facade height) is required on all street-facing facades of all nonresidential and multifamily buildings in the manner and in conformity with the standards provided in Illustration 4-7.

(2) Facade offsets must be shown, along with calculations verifying that the building elevations meet the above requirements, on a building Facade (elevation) Plan. The building Facade Plan must be submitted for review at the time of the initial development application along with the building elevations.

(3) Canopies, arches, and covered colonnades count toward applicable facade depth or height articulation requirements.

(4) Visual examples of acceptable facade articulation are provided in the photos which are provided below.

(C) Parking Structures.

(1) All above-grade parking structures must be designed to blend in with the architectural style of the main building(s), and must incorporate at least two of the following design elements:

(a) Distinctive architectural elements such as cornices, piers, columns, friezes, quoins, mullions, fenestration, pilasters, rustication, or accentuating belt courses. Examples of such distinctive architectural elements may be found in Illustration 2-8 in Chapter 2 of this GDC;

(b) Variation in wall planes such as wall openings, canopies, articulations, wall convexities, wall concavities, balconies, or awnings. Examples of such variation in wall planes may be found in Illustration 2-8 in Chapter 2 of this GDC; and

(c) Change in materials. Such a change must involve a minimum of two separate, compatible materials, excluding glazing. Each area covered by the separate material must cover at least twenty percent of each facade's surface area, excluding glazing.

(d) Change in colors. Such a change must involve a minimum of two, compatible color changes, excluding glazing. Each area covered by the color change must cover at least twenty percent of each facade's surface area, excluding glazing.

(2) All above-grade parking structures must be designed with a distinguishable first floor, upper facades, and roofs. Parking garage first floors must be designed at human scale with pedestrian-scale elements such as awnings, canopies, window breaks, and door openings.

(3) Above-grade parking garages may be designed using decorative metal elements such as ornate meshes, screens, and the like, but must not be allowed to have non-decorative steel guard cables that are visible to the public or to adjacent properties.

(D) Windows. Highly reflective mirror glass must not be used as an exterior building material on any building or structure. However, in order to encourage energy efficiency, the use of tinted or inward facing mirrored

glass is allowed and encouraged.

. . .

(E) Canopies. All canopies that are intended to shelter vehicles or vehicular traffic such as a building's porte cochere, a bank's drive-through canopy, or a fuel station canopy, must have support columns."

#### **Section 41**

That Section 4.84, "Residential Building Materials & Design", of Chapter 4, "Site Development", of the Garland Development Code of the City of Garland, Texas, is hereby renamed and amended in pertinent part to read as follows:

#### **"Section 4.84 Residential Design**

(A) Design Standards.

(1) Required Standards. All single-family, two-family, and townhouse residential structures must be designed in accordance with the following design standards, unless otherwise approved as Planned Development (PD) zoning or pursuant to Subsection 4.85 of this Article 6.

(2) Garages.

(a) The face of a garage door must be at least twenty feet from the street or alley right-of-way line that the garage door faces (twenty-four feet if facing an interior lot/property line), and must have at least one of the following designs, as depicted in Illustrations 4-9 through 4-13:

- i. Rear entry;
- ii. "J" drives, for front entry properties;
- iii. "Swing" drives, for side entry properties;  
or
- iv. Offset front entry with the garage door set back at least five feet behind the front building

face.

(3) Architectural Requirements. Each dwelling unit must be designed and built in accordance with the following minimum criteria:

(a) Architectural Relief. No facade of a dwelling unit facing a public street or any portion of an interior side or rear facade above the first story of a dwelling unit may contain a flat, unarticulated or uninterrupted wall length of greater than twenty percent of the horizontal length of the facade. Any such facade section must contain an offset of at least two or more feet. Illustrations 4-14 and 4-15 below are examples of dwelling units which do not meet this standard and which would be unacceptable.

(b) Minimum Number of Elevations. The front building elevation of a dwelling must not be duplicated on the three adjacent houses on both sides, or on the four houses directly across the street. This requirement may be waived by the Building Official if the building materials and the architectural elements, such as windows, dormers, facade offsets, or overhangs, of a home are significant enough to make the front facade of the home look substantially different from its neighboring structures.

(c) Minimum Number of Design Elements. A minimum of three of the following elements, as depicted in Illustrations 4-16 and 4-17, must be incorporated into the design of each dwelling unit:

- i. Multiple pane windows featuring either divided light or simulated divided light;
- ii. A front porch area enclosed by a railing at least thirty inches in height, and containing decorative columns at least six inches in

diameter;

iii. Gable(s) with window(s);

iv. Dormer(s);

v. Bay windows with a minimum projection of twenty-four inches;

vi. Minimum 8:12 roof pitch;

vii. Split garage doors with a separate door for each vehicle bay; or

viii. Front covered porch with at least forty square feet of usable space, and a minimum depth of five feet.

(d) Walls & Windows. Windows and doors must comprise at least twenty-five percent of the wall area of the front building face of a dwelling.

(e) Roof Design.

i. A roof pitch of at least 6:12 is required for each dwelling unit.

ii. Each dwelling unit must be constructed with a roof overhang of not less than eighteen inches, as measured from the finished exterior building facade to the soffit.

(4) Carports. Carports must meet the building materials and design requirements contained in Section 2.59 in Chapter 2 of this GDC.

(5) Exemptions. The following are exempt from the architectural requirements of this Section:

(a) Residential accessory structures, as may be provided in Article 5, Division 4 of Chapter 2 of this GDC; and

(b) Temporary buildings, but only if approved during the alternative compliance

review process as set forth in Section 4.85 of this Article 6, or in Article 1, Division 2 of this Chapter 4."

#### **Section 42**

That Section 4.85, "Administrative Approval of Alternative Materials", of Chapter 4, "Site Development", of the Garland Development Code of the City of Garland, Texas, is hereby renamed and amended to read as follows:

#### **"Section 4.85 Allowed Materials**

Unless stated otherwise in this GDC, a building may use a material approved by the applicable Relevant Model Code for a given application."

#### **Section 43**

That Section 5.21, "Dormant Projects", of Chapter 5, "Relief Procedures & Enforcement", of the Garland Development Code of the City of Garland, Texas, is hereby amended in pertinent part to read as follows:

#### **"Section 5.21 Dormant Projects**

(A) Definitions. For purposes of this section only:

(1) *Initial Permit* means any of the following types of applications or approvals granted under the Garland Comprehensive Zoning Ordinance or subdivision regulations (including Chapter 31 of the City Code), as amended, or any predecessor zoning, subdivision or development-related ordinance that was in effect prior to the effective date of this GDC: any Site Plan, Detail Plan, Preliminary Development Plan, Specific Use Permit/Provision, any type of plat, or any other application that was approved subject to a schematic drawing illustrating the location, arrangement, orientation, or design of land uses, lots, or improvements on a site intended for development.

. . ."

#### **Section 44**

That Section 6.03, "Definitions", of Chapter 6, "Definitions", of the Garland Development Code of the City of Garland, Texas, is hereby amended in pertinent part to read as follows:

**"Section 6.03 Definitions**

Following are the definitions of land uses, general terms, and special terms used in this GDC.

. . .

MARINA: (x) A waterfront business establishment for the docking, wet storage, refueling, and servicing of boats and personal watercraft used on the abutting lake or reservoir. The term includes watercraft fuel sales, fishing equipment and bait sales, fishing pier/services, boat/watercraft rentals, a restaurant(s), dry boat storage, and other amenities related to boating, fishing, and outdoors recreational enjoyment.

MASONRY MATERIALS: Masonry Materials are brick, stone, tile, or other similar building units or materials, or any combination of these materials, laid up unit-by-unit, and set in mortar. Notwithstanding the foregoing, Masonry Construction includes the following materials:

(a) Hard-fired brick such as kiln-fired clay, shale, or slate material. Acceptable materials may also include integrally-colored concrete brick, known as concrete masonry units or CMUs, but only subject to the limitations in Subsection 4.82(C)(1)(d) and only if the concrete masonry units conform to the same ASTM standard for construction as typical hard-fired clay brick. Material under this Section must meet the classification of severe weather grade and have a minimum thickness of two and one-quarter inches when applied as a veneer. Acceptable materials under this Section do not include unfired or underfired clay, sand, or shale brick.

(b) Stone such as naturally occurring granite, marble, limestone, slate, river rock, and other similar hard and durable, all-weather stone that is customarily used in exterior building

construction. Acceptable materials may also include cast or manufactured stone product, provided that such product yields a highly textured, stone-like appearance, its coloration is integral to the masonry material, and it is demonstrated to be highly durable and maintenance-free. The surface of any manufactured stone must not be painted. Natural or man-made stone must have a minimum thickness of two and five-eighths inches when applied as a veneer.

(c) Concrete masonry units, also known as CMUs, for nonresidential and multifamily projects only, provided that such concrete masonry units are integrally-colored, not painted, have a highly textured exterior finish such as "split-face," are classified as severe weather grade, and are not lightweight or featherweight concrete or cinder blocks.

Masonry Materials do not include any of the following:

- (a) Adobe or mortar wash surface material;
- (b) Exterior insulation and finish system (EIFS), acrylic matrix, synthetic plaster, or other similar synthetic material;
- (c) Cementitious fiberboard siding, such as "SmartBoard" or "HardiBoard";
- (d) Vinyl-based siding material, as may be allowed by the City's Building Code;
- (e) Lightweight or featherweight concrete blocks or cinder blocks;
- (f) Exterior plaster, including stucco; and
- (g) Any other cementitious product not listed above.

MASSAGE THERAPY: A type of personal service that offers therapeutic massage by a massage therapist (as defined and licensed by state law).

. . .

MOBILE SERVICE VENDOR: A mobile service business that typically travels to most, if not all, of its customers rather than its customers coming to the business's shop (such as, a mobile automotive windshield installer, mobile veterinary clinic, mobile pet-bathing service, or mobile locksmith). The term does not include retail sales of any goods or items other than those installed or expended in the actual conduct of the mobile service (such as, a windshield that is installed by a mobile installer, vaccinations and supplies delivered and administered by a mobile veterinary clinic, or door locks and keys cut and sold by a mobile locksmith).

MODEL CODE: A publication that is developed, promulgated, and periodically updated at a national level by organizations consisting of industry and government fire and building safety officials through a legislative or consensus process and that is intended for consideration by units of government as local law, including but not limited to, the International Residential Code, International Plumbing Code, International Electrical Code, International Mechanical Code, the National Electrical Code, the International Building Code, the International Fire Code, the International Fuel Gas Code, and the International Energy Conservation Code.

MONEY TRANSFER BUSINESS: An establishment, other than a financial institution or a bank that engages in or facilitates the transmission of monetary funds to or from a location outside the United States and its territories for a fee.

. . .

REHABILITATION FACILITY: (x) As defined by Chapter 244 of the Texas Local Government Code, a residential facility that is operated by an agency of the state, a political subdivision of the state, or a private vendor operating under a contract with an agency of the state or a political subdivision of the state and that houses persons convicted of misdemeanors or felonies or houses children found to have engaged in delinquent conduct, regardless of whether the persons are housed in the residential facility:

- a. While serving a sentence of confinement following conviction of an offense;

b. As a condition of probation, parole, or mandatory supervision; or

c. Under a court order for out-of-home placement under Title 3, Family Code, other than in a foster home operated under contract with the juvenile board of the county in which the foster home is located or under a contract with the Texas Youth Commission.

Such facility and the persons that reside therein must meet all the specifications and requirements of Chapter 244 of the Texas Local Government Code to be considered a Rehabilitation Facility under this GDC. In the event of a conflict between this definition and the definition provided by Chapter 244 of the Texas Local Government Code, state law shall control.

RELEVANT MODEL CODE: A Model Code published within the last three code cycles and which applies to construction, renovation, maintenance, or other alteration of a Building.

REMAINDER TRACT: Land that is part of a larger parcel that is not subject to a subdivision plat affecting the parcel.

. . ."

#### **Section 45**

That Section 7.11, "Building Standards", of Chapter 7, "Downtown (DT) District", of the Garland Development Code of the City of Garland, Texas, is hereby amended in pertinent part to read as follows:

#### **"Section 7.11 Building Standards**

. . .

(D) Residential At-Grade.

. . .

(6) Masonry columns may be used on patios and fences provided that the columns are used as accents. Wood fences and railings, chain-link

fencing, and vinyl fencing materials are prohibited.

(7) For buildings located within the boundaries of any Historic District recognized by the United States Department of the Interior on or before April 1, 2019, balcony and patio railings and fences shall be largely transparent and constructed of glass, wrought iron or metal or a combination thereof.

. . .

(I) Roofs.

(1) Flat roofs and green roofs are allowed.

(2) For buildings located within the boundaries of any Historic District recognized by the United States Department of the Interior on or before April 1, 2019, which have with hip, gable or mansard roofs, the allowed materials include slate, concrete or clay roofing tile, copper, factory-finished standing seam metal or laminated asphalt shingles of at least three hundred pounds per square. Wood shingles are expressly prohibited.

. . .

(J) Exterior walls. For buildings located within the boundaries of any Historic District recognized by the United States Department of the Interior on or before April 1, 2019, the following standards apply:

(1) Exterior walls of buildings and parking structures that are visible from a street, plaza or other public open space (excluding windows, doors, breezeways and other openings) shall be constructed of at least eighty percent masonry materials, as defined in this GDC.

(2) Concrete tilt wall, pre-cast concrete panels, and other similar materials are prohibited.

(3) No more than twenty percent of each facade

along a street shall use accent materials such as wood, architectural metal panel or tile.

(4) EIFS shall be allowed only as a material for trim and moldings more than eight feet above the ground floor.

(5) Glass curtain wall may be allowed for lofts and nonresidential uses provided it does not constitute more than seventy-five percent of the facade.

(6) Other exterior walls which are not visible from a street, plaza or other public open space shall be constructed of at least twenty percent masonry materials, with the remaining being noncombustible materials, including exterior 3-stage stucco, cementitious fiberboard, or other material approved by Minor Waiver and allowed under the International Building Code."

#### **Section 46**

That Section 7.12, "Automobile Parking", of Chapter 7, "Downtown (DT) District", of the Garland Development Code of the City of Garland, Texas, is hereby amended in pertinent part to read as follows:

#### **"Section 7.12 Automobile Parking**

. . .

(C) Parking Garages.

. . .

(2) Where a parking garage must be located adjacent to a street:

(a) Parking garages shall be landscaped as set out in Article 6 of this Chapter 7.

(b) The parking structure facades shall be designed to be compatible with the Downtown district's character. Architectural screens may be used to articulate the facade, hide

parked vehicles, and shield lighting.

(c) Parking structures and adjacent sidewalks shall be designed so pedestrians are clearly visible to entering and exiting automobiles.

(d) Off-street below-grade parking may be built to the lot lines, but shall be designed to allow landscape planting at-grade as defined in Article 6 of this Chapter 7. No below-grade parking beneath a building shall be visible from the sidewalk.

(e) For parking structures located within the boundaries of the Garland Downtown Historic District, as recognized by the United States Department of the Interior, the structure must comply with this Chapter's masonry materials requirement.

. . ."

#### **Section 47**

That Section 7.28, "Downtown Development Plan", of Chapter 7, "Downtown (DT) District", of the Garland Development Code of the City of Garland, Texas, is hereby amended in pertinent part to read as follows:

#### **"Section 7.28 Downtown Development Plan**

. . .

(C) An application for a Downtown Development Plan shall be processed in accordance with the City's procedures set forth in Article 2, Division 1 of Chapter 1 of this GDC.

. . ."

#### **Section 48**

That Section 7.29, "Regulating Plan", of Chapter 7, "Downtown (DT) District", of the Garland Development Code

of the City of Garland, Texas, is hereby amended in pertinent part to read as follows:

**"Section 7.29 Regulating Plan**

. . .

(F) An application for a Regulating Plan shall be processed in accordance with the City's procedures set forth in Article 2, Division 1 of Chapter 1 of this GDC.

. . ."

**Section 49**

That Article 9, "Definitions", of Chapter 7, "Downtown District", of the Garland Development Code of the City of Garland, Texas, is hereby numbered as Section 7.50 and amended to read as follows:

**"Section 7.50 Definitions**

The following definitions apply only within the Downtown District. Other definitions within this GDC shall govern when not in direct conflict with the terms below. If, however, there is a conflict the following definitions shall control within the Downtown District.

*Access Drive.* Any on-site drive or lane intended to accommodate motor vehicles or pedestrians.

*Apartment.* A multifamily structure containing three or more dwelling units located on a single lot and designed to be occupied by three or more families living independently of one another, excluding hotels or motels.

*Awning.* A roof-like cover supported from the exterior wall of a building, often of fabric, metal or glass, designed and intended to provide protection from the elements.

*Block Face.* One side of a street between two consecutive street intersections.

*Building Facade, Primary.* Any facade that faces a public street or open space.

*Build-To Zone.* The Build-To Zone establishes the minimum and maximum setback for a building facade from the curb line on private property.

*Commercial Building.* A building that contains nonresidential space/use, but no residential use.

*Condominium, Residential.* A building in which the space in each dwelling unit is owned individually, and all of the dwelling owners share in the ownership of the common areas, such as grounds and the building structures.

*Director.* The Planning Director, or designee.

*Dismount Strip.* A narrow width of paving between the back-of-curb of an on-street parking space and a planter or tree well. It enables passengers to more easily exit a parked vehicle and gain access to the sidewalk.

*Downtown Development Plan.* A plan that must be approved by the City prior to any improvements to a property with the Downtown (DT) district. An approved Downtown Development Plan is required prior to the issuance of site or building permits. (See Section 7.28 of this Chapter 7)

*Duplex.* A freestanding building on one lot, having separate accommodations for and occupied by not more than two families, one family in each living unit.

*Entry, Primary.* The main entry to a building or lease space on a block face. Such entries may also be located on a plaza or courtyard with direct access to the street.

*Flex Space.* Leasable space which has the necessary ceiling height and fire separation to accommodate retail and restaurant uses, though any allowed nonresidential use may occupy the space until the retail market matures to a level that will cause the space to change to a retail or restaurant use.

*Framework Plan.* The Framework Plan (see Appendix 3) adopted as part of this Chapter 7, and used as a guide for the application of these district regulations.

*Frontage.* Any portion of a lot that is immediately adjacent to a street. This does not include alleys.

*Landmark Building.* A building located on axis with a terminating street or public access drive or at the intersection of two or more streets. Such building shall incorporate architectural features that address height and articulation that emphasize the importance of such a location and shall be approved as part of the Downtown Development Plan.

*Liner Building.* A narrow building that lines the exterior of a parking garage structure adjacent to a street and sidewalk. It is generally thirty to sixty feet deep and occupied by any allowed use except parking.

*Live/Work.* Units containing both living quarters and a commercial space, such as retail, artist space or gallery, business or other professional office activities where the living and working areas shall each have a separate entry from a public walkway, and the residential component is located above the commercial use.

*Loft.* A flexible residential or commercial space characterized by higher than normal ceilings, open floor plans and, often, exposed duct work. Lofts may be found in Mixed Residential, Commercial and Mixed-Use buildings.

*Masonry Material.* See Chapter 6 of this GDC (Definitions).

*Mixed Residential.* A building containing a variety of residential unit sizes or types, such as studio, 1-, 2- or 3-bedroom apartments, condominiums or lofts.

*Mixed-Use Building.* A structure that combines residential and nonresidential uses in a single building.

*Mullion.* The vertical or horizontal divisions or joints between single windows in a multiple window unit.

*Pedestrian Shed.* A Pedestrian Shed is an area where the center is an average one-quarter mile radius, about the distance of a five-minute walk at a leisurely pace.

*Setback, Downtown.* The area between the edge of the sidewalk and the building face under private ownership. In nonresidential adjacency, this area may include landscaping or outdoor seating and may be paved. In residential adjacency, the area will be landscaped and may include stoops, stairs and patios.

*Stoop.* A porch with steps that is located approximately at the level of the first floor of the structure and intended to provide access to a residential unit.

*Streetscape.* The urban design element that establishes the character for the major part of the public realm. The streetscape is composed of thoroughfares (travel lanes for vehicles and bicycles, parking lanes for cars, sidewalks for pedestrians) as well as the visible private frontages (building facades and elevations, porches, setbacks, fences, awnings, etc.) and the amenities within the public frontages (street trees and plantings, benches, streetlights, bike facilities, other furnishings).

*Studio Apartment.* A small apartment usually consisting of one main area that combines the living and bedroom space, as well as a small kitchen/kitchenette and a bathroom.

*Townhome.* An attached dwelling unit, typically with a height of two or more stories, located on a separately platted lot, which shares at least one common wall with another such unit, typically grouped together in a cluster of 3 or more units.

*Waiver to Design Standards, Major (Major Waiver).* A change to or deviation from the standards of this District, as identified in the District regulations and requiring City Plan Commission recommendation and City Council approval.

*Waiver to Design Standards, Minor (Minor Waiver).* A change to the standards of this district that is not contrary to the stated goals and intent of the District as interpreted and authorized by the Director."

## **Section 50**

That Exhibit A, "Fee Schedule", to the Garland Development Code of the City of Garland, Texas, is hereby repealed.

## **Section 51**

That Garland Development Code for the City of Garland, Texas, as amended, shall be and remain in full force and effect save and except as amended by this Ordinance.

**Section 52**

That a violation of any provision of this Ordinance shall be a misdemeanor punishable in accordance with Sec. 10.05 of the Code of Ordinances of the City of Garland, Texas.

**Section 53**

That the terms and provisions of this Ordinance are severable and are governed by Sec. 10.06 of the Code of Ordinances of the City of Garland, Texas.

**Section 54**

That this Ordinance shall be and become effective immediately upon and after its passage and approval.

**PASSED AND APPROVED** this the 20<sup>th</sup> day of August, 2019.

**CITY OF GARLAND, TEXAS**

\_\_\_\_\_  
Mayor

**ATTEST:**

\_\_\_\_\_  
City Secretary

**PUBLISHED:**