

ORDINANCE NO. 702
HATFIELD TOWNSHIP
MONTGOMERY COUNTY, PENNSYLVANIA

**A HATFIELD TOWNSHIP ORDINANCE AMENDING CHAPTER 112
ENTITLED “CONSTRUCTION CODES, UNIFORM”, SECTION 2
ENTITLED “ADOPTION OF UNIFORM CONSTRUCTION CODE” FOR
THE PURPOSE OF ADOPTING THE NATIONAL FIRE PROTECTION
ASSOCIATION (NFPA) 855 – STANDARD FOR THE INSTALLATION
OF STATIONARY ENERGY STORAGE SYSTEMS (2023 EDITION)**

WHEREAS, the First Class Township Code authorizes the Board of Commissioners to make and adopt Ordinances that are consistent with the Constitution and the laws of the Commonwealth that it deems necessary for the proper management and control of the Township and welfare of the Township and its citizens;

WHEREAS, the Board of Commissioners, after due consideration of the proposed ordinance at a duly advertised public hearing, has determined that the health, safety, and general welfare of the residents of Hatfield Township will be served by amending Chapter 112 of the Hatfield Township Code entitled “Construction Codes, Uniform”, Section 2, entitled “Adoption of Uniform Construction Code” for the purpose of adopting the National Fire Protection Association (NFPA) 855 – Standard for the Installation of Stationary Energy Storage Systems (2023 edition);

NOW, THEREFORE, BE IT ORDAINED AND ENACTED by the Board of Commissioners for Hatfield Township, and it is hereby ordained and enacted, by the authority of the same, to wit:

SECTION 1. CODE AMENDMENT.

- A. Chapter 112 of the Hatfield Township Code entitled “Construction Codes, Uniform”, Section 2, entitled “Adoption of Uniform Construction Code” is hereby amended to add a new subparagraph C to read as follows:**

National Fire Protection Association (NFPA) 855 – Standard for the Installation of Stationary Energy Storage Systems (2023 edition), as amended, along with the appendixes which shall be used as guides for enforcement and/or interpretation of the provisions as indicated therein.

SECTION 2. REPEALER.

All Ordinances or parts of Ordinances inconsistent herewith or in conflict with any of the specific terms enacted hereby, to the extent of said inconsistencies or conflicts, are hereby specifically repealed.

SECTION 3. REVISIONS.

The Hatfield Township Board of Commissioners does hereby reserve the right, from time to time, to adopt modifications of, supplements to, or amendments of its Ordinance, including this provision.

SECTION 4. SEVERABILITY.

In the event that any section, sentence, clause, phrase or word of this Ordinance shall be declared illegal, invalid or unconstitutional by any Court of competent jurisdiction, such declaration shall not prevent, preclude or otherwise foreclose enforcement of any of the remaining portions of this Ordinance.

SECTION 5. EFFECTIVE DATE.

This amendment shall become effective immediately upon adoption.

SECTION 6. FAILURE TO ENFORCE NOT A WAIVER.

The failure of Hatfield Township to enforce any provision of this Ordinance shall not constitute a waiver by the Township of its rights of future enforcement hereunder.

ORDAINED AND ENACTED by the Board of Commissioners for Hatfield Township, Montgomery County, Pennsylvania, this 23rd day of August, 2023.

ATTEST:

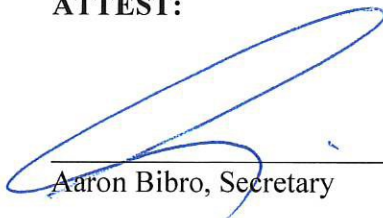

Aaron Bibro, Secretary

**BOARD OF COMMISSIONERS OF
HATFIELD TOWNSHIP**



Thomas C. Zipfel, President

Copyright © 2022 National Fire Protection Association®. All Rights Reserved.

NFPA® 855

Standard for the

Installation of Stationary Energy Storage Systems

2023 Edition

This edition of NFPA 855, *Standard for the Installation of Stationary Energy Storage Systems*, was prepared by the Technical Committee on Energy Storage Systems and acted on by the NFPA membership during the 2022 NFPA Technical Meeting held June 8-9. It was issued by the Standards Council on August 12, 2022, with an effective date of September 1, 2022, and supersedes the previous edition.

This edition of NFPA 855 was approved as an American National Standard on September 1, 2022.

Origin and Development of NFPA 855

The energy storage system project that led to the first edition of NFPA 855, *Standard for the Installation of Stationary Energy Storage Systems*, was approved by the NFPA Standards Council in April of 2016, after which a call for members was posted. The original request was submitted by an individual on behalf of the California Energy Storage Alliance to address gaps in regulation identified in workshops held by the US Department of Energy and the Fire Protection Research Foundation. In August of that same year, the Standards Council appointed the first NFPA Technical Committee on Energy Storage Systems. The initial draft was developed over the course of three meetings by the technical committee and was released to the public in 2017. Over the next 2 years, the technical committee met several times to review feedback from the public and to make improvements to the standard.

The first edition was issued by the Standards Council on August 5, 2019.

The 2023 edition includes a scope which covers all energy storage systems and lithium battery storage. Application of NFPA 855 to an ESS installation is left to the mandatory or voluntary adoption of the standard. Exemptions specific to installations under the exclusive control of utilities have been incorporated throughout the standard to address concerns if NFPA 855 is adopted for utility use.

In response to international incidents of ESS fires, requirements for fire detection and suppression, explosion control, exhaust ventilation, gas detection, and thermal runaway have been added or revised. The requirements for fire and explosion testing (formally large-scale fire testing) have been clarified.

Requirements from Chapters 4 and 10 specific to electrochemical ESS have been consolidated and reorganized in Chapter 9. Chapter 13 has been added to address flywheel ESS.

Information has been added in Annex B to provide guidance on the hazards associated with additional battery types. Annex G has been added as a guide for suppression and safety of lithium-ion battery ESS.

Technical Committee on Energy Storage Systems

James B. Biggins, *Chair*

TUV SUD America Inc/Global Risk Consultants Corporation, IL [SE]

Rotem Antman, Code Fire & Safety Engineering, Israel [SE]
Curtis Ashton, American Power Systems/East Penn Manufacturing
 Deka Services, CO [M]
Gerard G. Back, JENSEN HUGHES, MD [SE]
Brandon Bartling, 3M Company, MN [M]
Denise Beach, FM Global, MA [I]
Zekarias Bekele, CSA Group, OH [RT]
Hubert Biteau, S-E-A, Ltd., CO [SE]
Andrew Blum, Fisher Engineering, Inc., GA [SE]
William P. Cantor, TPI Corporation, PA [U]
 Rep. IEEE-IAS/PES/JTCC
Troy Chatwin, Wabtech/GE Energy Storage, NY [M]
Stephen W. Douglas, QPS Evaluation Services Inc., Canada [RT]
Laurie B. Florence, UL LLC, IL [RT]
Kevin Fok, LG Energy Solution Michigan, Inc., MI [M]
Kara Gerczynski, Elizabeth Fire Protection District, CO [E]
 Rep. International Association of Fire Chiefs
Jan Gromadzki, Tesla, CA [M]
Nicholas Guzman, Enel Green Power North America, Inc.
 (EGPNA), NV [U]
Paul Hayes, American Fire Technologies, NC [IM]
Darryl Hill, Wichita Electrical JATC/IBEW 271, KS [L]
 Rep. International Brotherhood of Electrical Workers
John A. Hillaert, MPR Associates Inc., VA [SE]
James Houston, Southern Company Services, AL [U]
Jonathan G. Ingram, Carrier/Kidde-Fenwal, Inc., MA [M]
Brad Kell, Unienergy Technologies, WA [M]
Chad Kennedy, Schneider Electric, SC [M]
 Rep. National Electrical Manufacturers Association
Jason Knedlhans, Able Grid Energy Solutions, CO [IM]

Paul Kozak, Consultant, Canada [SE]
Angela Krcmar, Firetrace International, AZ [M]
Celina Mikolajczak, Panasonic Energy of North America (PENA),
 NV [M]
Mark Christopher Mirek, Beecher Carlson LLC, TX [I]
Anthony Natale, Consolidated Edison of New York, NY [U]
 Rep. Edison Electric Institute
Cliff Orvedal, Fluence Energy, VA [M]
Matthew Paiss, Pacific Northwest National Laboratory (PNNL), WA
 [SE]
Justin A. Perry, Dominion Energy, VA [U]
Scot Pruett, Black & Veatch Corporation, KS [SE]
Paul G. Rogers, International Association of Fire Fighters (IAFF),
 NY [L]
 Rep. International Association of Fire Fighters
Richard Karl Schlueck, Fire Department City of New York (FDNY),
 NY [E]
Brian Scholl, Phoenix Fire Department, AZ [E]
Randy H. Schubert, Ericsson, NJ [U]
 Rep. Alliance for Telecommunications Industry Solutions
Andrzej Skoskiewicz, Stem, Inc., CA [M]
Nicholas Aaron Stone, Eaton Corporation, CA [M]
K. Ken Sun, Hartford Steam Boiler (HSB) Munich Re-Risk
 Engineering, CT [I]
Chris Towski, Cambridge Fire Department, MA [E]
 Rep. Fire Prevention Association of Massachusetts, Inc. (FPAM)
Nick Warner, Warner Energy Storage Solutions, OH [SE]
Ronald W. Woodfin, TetraTek, Inc./AES Corporation, CO [U]
Daniel Youngs, Saft America Batteries, CT [M]
Tom Zornes, Siemens, IN [M]
 Rep. Fire Suppression Systems Association

Alternates

John Armstrong, Dominion Energy, VA [U]
 (Alt. to Justin A. Perry)
Gary Balash, East Penn Manufacturing Company, PA [M]
 (Alt. to Curtis Ashton)
Jim P. Barrett, Enel X North America/ Demand Energy Networks,
 WA [U]
 (Alt. to Nicholas Guzman)
Thomas Bensen, Bensen Fire & Safety Consulting, Ltd., OH [SE]
 (Alt. to Nick Warner)
Jens Conzen, JENSEN HUGHES, IL [SE]
 (Alt. to Gerard G. Back)
Robert J. Davidson, Davidson Code Concepts, LLC, SC [M]
 (Alt. to Celina Mikolajczak)
Eric Dein, Black & Veatch, KS [SE]
 (Alt. to Scot Pruett)
Benjamin Ditch, FM Global, MA [I]
 (Alt. to Denise Beach)
Dennis W. Eaves, Beecher Carlson, GA [I]
 (Alt. to Mark Christopher Mirek)
Byron E. Ellis, Entergy Corporation, LA [U]
 (Alt. to Anthony Natale)
Becca Gillespie, Unienergy Technology, WA [M]
 (Alt. to Brad Kell)

Lou Grahor, Eaton Corporation, PA [M]
 (Alt. to Nicholas Aaron Stone)
Howard Hopper, UL LLC, CA [RT]
 (Alt. to Laurie B. Florence)
Nick Johnson, 3M Company, MN [M]
 (Alt. to Brandon Bartling)
Richard G. Kluge, Ericsson, NJ [U]
 (Alt. to Randy H. Schubert)
Scott R. Lang, Honeywell International, IL [M]
 (Alt. to Chad Kennedy)
Jody Leber, CSA Group, GA [RT]
 (Alt. to Zekarias Bekele)
José A. Marrero, Southern Company, AL [U]
 (Alt. to James Houston)
Dan Patry, Fluence Energy, CO [M]
 (Alt. to Cliff Orvedal)
Nicholas Petrakis, Fire Department City of New York (FDNY), NY
 [E]
 (Alt. to Richard Karl Schlueck)
Charles Picard, Tesla, CA [M]
 (Alt. to Jan Gromadzki)
Shaun Thomas Ryan, Fisher Engineering, AZ [SE]
 (Alt. to Andrew Blum)

Leo Subbarao, Fire Prevention Association of Massachusetts, NY [E]
(Alt. to Chris Towski)

Christopher Coache, NFPA Staff Liaison

This list represents the membership at the time the Committee was balloted on the final text of this edition. Since that time, changes in the membership may have occurred. A key to classifications is found at the back of the document.

NOTE: Membership on a committee shall not in and of itself constitute an endorsement of the Association or any document developed by the committee on which the member serves.

Committee Scope: This committee shall have primary responsibility for documents on the fire prevention, fire protection, design, construction, installation, commissioning, operation, maintenance, and decommissioning of stationary, mobile and temporary energy storage systems.

Contents

Chapter 1 Administration	855- 5	Chapter 10 (Reserved)	855- 27
1.1 Scope.	855- 5	Chapter 11 Fuel Cell Energy Storage Systems	855- 27
1.2 Purpose.	855- 5	11.1 Installation and Maintenance.	855- 27
1.3 Application.	855- 5	11.2 Fuel-Cell-Powered Vehicle Use.	855- 27
1.4 Retroactivity.	855- 5	Chapter 12 Superconducting Magnet Energy Storage	
1.5 Equivalency.	855- 5	(Reserved)	855- 27
1.6 Units and Formulas.	855- 6	Chapter 13 Flywheel Energy Storage Systems (FESS) ..	855- 27
Chapter 2 Referenced Publications	855- 6	13.1 Application.	855- 27
2.1 General.	855- 6	13.2 Protection Features.	855- 27
2.2 NFPA Publications.	855- 6	13.3 Commissioning.	855- 28
2.3 Other Publications.	855- 6	13.4 Operation and Maintenance.	855- 28
2.4 References for Extracts in Mandatory Sections.	855- 7	13.5 Decommissioning.	855- 29
Chapter 3 Definitions	855- 7	Chapter 14 Storage of Lithium Metal or Lithium-ion	
3.1 General.	855- 7	Batteries	855- 29
3.2 NFPA Official Definitions.	855- 7	14.1 Batteries.	855- 29
3.3 General Definitions.	855- 7	14.2 Collection Locations.	855- 29
Chapter 4 General	855- 9	14.3 Indoor Storage Locations.	855- 29
4.1 General.	855- 9	14.4 Prevention and Mitigation.	855- 30
4.2 Construction Documents.	855- 9	14.5 Explosion Protection.	855- 30
4.3 Emergency Planning and Training.	855- 9	14.6 Outdoor Storage Location.	855- 30
4.4 Hazard Mitigation Analysis (HMA).	855- 10	Chapter 15 One- and Two-Family Dwellings and	
4.5 Combustible Storage.	855- 10	Townhouse Units	855- 30
4.6 Equipment.	855- 10	15.1 General.	855- 30
4.7 Installation.	855- 11	15.2 Equipment Listings.	855- 30
4.8 Smoke and Fire Detection.	855- 13	15.3 Installation.	855- 30
4.9 Fire Control and Suppression.	855- 13	15.4 Locations.	855- 30
4.10 Mobile ESS Equipment and Operations.	855- 14	15.5 Energy Ratings.	855- 31
Chapter 5 System Interconnections	855- 14	15.6 Electrical Installation.	855- 31
5.1 General.	855- 14	15.7 Fire Detection.	855- 31
5.2 Disconnecting Means.	855- 14	15.8 Protection from Impact.	855- 31
5.3 Nonelectrical Systems.	855- 14	15.9 Exhaust Ventilation.	855- 31
5.4 Support Systems.	855- 14	15.10 ESS Toxic and Highly Toxic Gas Release	
Chapter 6 Commissioning	855- 14	During Normal Use.	855- 31
6.1 System Commissioning.	855- 14	15.11 Electric Vehicle Use.	855- 31
6.2 Issues and Resolutions Documentation.		Annex A Explanatory Material	855- 31
(Reserved)	855- 15	Annex B Battery Energy Storage System Hazards ...	855- 41
6.3 Operations and Maintenance Documentation. .	855- 15	Annex C Firefighting Considerations (Operations) .	855- 52
6.4 Recommissioning of Existing Systems.	855- 15	Annex D Overview of Energy Storage Systems	
Chapter 7 Operation and Maintenance	855- 15	Technologies	855- 56
7.1 System Operation.	855- 15	Annex E Permits, Inspections, Approvals, and	
7.2 System Maintenance.	855- 16	Connections	855- 60
7.3 System Testing.	855- 16	Annex F Fire and Building Codes A Short History	
Chapter 8 Decommissioning	855- 16	on Stationary Storage Battery Systems	855- 60
8.1 Decommissioning Plan.	855- 16	Annex G Guide for Suppression and Safety of	
8.2 Decommissioning Process.	855- 17	Lithium-Ion Battery (LIB) Energy Storage	
8.3 Decommissioning Report.	855- 17	Systems (ESS)	855- 66
Chapter 9 Electrochemical Energy Storage Systems ..	855- 17	Annex H Informational References	855- 108
9.1 General.	855- 17	Index	855- 111
9.2 Equipment.	855- 17		
9.3 Location Classification.	855- 18		
9.4 Installation.	855- 18		
9.5 Location and Applications.	855- 19		
9.6 Protection and Remediation.	855- 23		

NFPA 855

Standard for the

Installation of Stationary Energy Storage Systems

2023 Edition

IMPORTANT NOTE: This NFPA document is made available for use subject to important notices and legal disclaimers. These notices and disclaimers appear in all publications containing this document and may be found under the heading "Important Notices and Disclaimers Concerning NFPA Standards." They can also be viewed at www.nfpa.org/disclaimers or obtained on request from NFPA.

UPDATES, ALERTS, AND FUTURE EDITIONS: New editions of NFPA codes, standards, recommended practices, and guides (i.e., NFPA Standards) are released on scheduled revision cycles. This edition may be superseded by a later one, or it may be amended outside of its scheduled revision cycle through the issuance of Tentative Interim Amendments (TIAs). An official NFPA Standard at any point in time consists of the current edition of the document, together with all TIAs and Errata in effect. To verify that this document is the current edition or to determine if it has been amended by TIAs or Errata, please consult the National Fire Codes® Subscription Service or the "List of NFPA Codes & Standards" at www.nfpa.org/docinfo. In addition to TIAs and Errata, the document information pages also include the option to sign up for alerts for individual documents and to be involved in the development of the next edition.

NOTICE: An asterisk (*) following the number or letter designating a paragraph indicates that explanatory material on the paragraph can be found in Annex A.

A reference in brackets [] following a section or paragraph indicates material that has been extracted from another NFPA document. Extracted text may be edited for consistency and style and may include the revision of internal paragraph references and other references as appropriate. Requests for interpretations or revisions of extracted text shall be sent to the technical committee responsible for the source document.

Information on referenced and extracted publications can be found in Chapter 2 and Annex G.

Chapter 1 Administration

1.1* **Scope.** This standard applies to the design, construction, installation, commissioning, operation, maintenance, and decommissioning of stationary energy storage systems (ESS), including mobile and portable ESS installed in a stationary situation and the storage of lithium metal or lithium-ion batteries.

1.2 Purpose. This standard provides the minimum requirements for mitigating the hazards associated with ESS and the storage of lithium metal or lithium-ion batteries.

1.3* **Application.** This standard shall apply to ESS installations exceeding the values shown in Table 1.3 and the storage of lithium metal or lithium-ion batteries.

1.3.1* ESS shall comply with the requirements of this standard as applicable.

1.3.2 ESS installed in one- and two-family dwellings and townhouse units shall only be required to comply with Chapter 15.

Table 1.3 Threshold Quantities per Each Fire Area or Outdoor Installation

ESS Technology	Aggregate Capacity ^a	
	kWh	MJ
Battery ESS		
Lead-acid, all types	70	252
Ni-Cad, Ni-MH, and Ni-Zn	70	252
Lithium-ion, all types	20	72
Sodium nickel chloride	20 (70 ^b)	72 (252 ^b)
Flow batteries ^c	20	72
Other battery technologies	10	36
Batteries in one- and two-family dwellings and townhouse units	1	3.6
Capacitor ESS		
Electrochemical double layer capacitors ^d	3	10.8
Other ESS		
All other ESS	70	252
Flywheel ESS (FESS)	0.5	1.8

^aFor ESS units rated in amp-hrs, kWh equals nominal rated voltage multiplied by amp-hr nameplate rating divided by 1000. For batteries rated in watts per cell, kWh equals the nameplate watts per cell multiplied by the number of cells divided by 1000 and multiplied by the nameplate minutes rating divided by 60.

^bFor sodium-nickel-chloride batteries that have been listed to UL 1973 and meet the cell-level performance requirements in UL 9540A.

^cIncludes vanadium, zinc-bromine, polysulfide-bromide, and other flowing electrolyte-type technologies.

^dCapacitors used for power factor correction, filtering, and reactive power flow are exempt.

1.3.3 Mobile ESS deployed at an electric utility substation or generation facility for 90 days or less shall not add to the threshold values in Table 1.3 for the stationary ESS installation if both of the following conditions apply:

- (1) The mobile ESS complies with 9.5.3.2.
- (2) The mobile ESS is only being used during periods in which a facility's stationary ESS is being tested, repaired, retrofitted, or replaced.

1.3.4 The storage of lithium metal or lithium-ion batteries shall only be required to comply with Chapter 14.

1.4 Retroactivity.

1.4.1 Unless otherwise specified, the provisions of this standard shall not apply to ESS installations that existed or were approved for construction or installation prior to the effective date of this standard.

1.4.2* In those cases where the authority having jurisdiction (AHJ) determines that an existing situation presents an unacceptable degree of risk, the AHJ shall be permitted to apply retroactively any portions of this standard deemed appropriate.

1.5* Equivalency. Nothing in this standard is intended to prevent the use of systems, methods, or devices of equivalent or superior quality, strength, fire resistance, effectiveness, durability, reliability, and safety over those prescribed in this standard.

1.6 Units and Formulas. Metric units in this standard shall be in accordance with the International System of Units, which is officially abbreviated SI in all languages.

Chapter 2 Referenced Publications

2.1 General. The documents or portions thereof listed in this chapter are referenced within this standard and shall be considered part of the requirements of this document.

2.2 NFPA Publications. National Fire Protection Association, 1 Batterymarch Park, Quincy, MA 02169-7471.

NFPA 1, *Fire Code*, 2021 edition.

NFPA 2, *Hydrogen Technologies Code*, 2023 edition.

NFPA 12, *Standard on Carbon Dioxide Extinguishing Systems*, 2022 edition.

NFPA 13, *Standard for the Installation of Sprinkler Systems*, 2022 edition.

NFPA 15, *Standard for Water Spray Fixed Systems for Fire Protection*, 2022 edition.

NFPA 24, *Standard for the Installation of Private Fire Service Mains and Their Appurtenances*, 2022 edition.

NFPA 30, *Flammable and Combustible Liquids Code*, 2021 edition.

NFPA 52, *Vehicular Natural Gas Fuel Systems Code*, 2023 edition.

NFPA 54, *National Fuel Gas Code*, 2021 edition.

NFPA 58, *Liquefied Petroleum Gas Code*, 2020 edition.

NFPA 68, *Standard on Explosion Protection by Deflagration Venting*, 2018 edition.

NFPA 69, *Standard on Explosion Prevention Systems*, 2019 edition.

NFPA 70[®], *National Electrical Code[®]*, 2023 edition.

NFPA 72[®], *National Fire Alarm and Signaling Code[®]*, 2022 edition.

NFPA 76, *Standard for the Fire Protection of Telecommunications Facilities*, 2020 edition.

NFPA 750, *Standard on Water Mist Fire Protection Systems*, 2023 edition.

NFPA 770, *Standard on Hybrid (Water and Inert Gas) Fire-Extinguishing Systems*, 2021 edition.

NFPA 853, *Standard for the Installation of Stationary Fuel Cell Power Systems*, 2020 edition.

NFPA 1142, *Standard on Water Supplies for Suburban and Rural Firefighting*, 2022 edition.

NFPA 2001, *Standard on Clean Agent Fire Extinguishing Systems*, 2022 edition.

NFPA 2010, *Standard for Fixed Aerosol Fire-Extinguishing Systems*, 2020 edition.

2.3 Other Publications.

2.3.1 ANSI Publications. American National Standards Institute, Inc., 25 West 43rd Street, 4th Floor, New York, NY 10036.

ANSI Z535.1, *American National Standard for Safety Colors*, 2011.

ANSI Z535.2, *American National Standard for Environmental and Facility Safety Signs*, 2011.

ANSI Z535.3, *American National Standard for Criteria for Safety Symbols*, 2011.

ANSI Z535.4, *American National Standard for Product Safety Signs and Labels*, 2011.

ANSI Z535.5, *American National Standard for Safety Tugs and Barricade Tapes (for Temporary Hazards)*, 2011.

ANSI Z535.6, *American National Standard for Product Safety Information in Product Manuals, Instructions, and Other Collateral Materials*, 2011.

2.3.2 ASTM Publications. ASTM International, 100 Barr Harbor Drive, P.O. Box C700, West Conshohocken, PA 19428-2959.

ASTM E108, *Standard Test Methods for Fire Tests of Roof Coverings*, 2020a.

ASTM E119, *Standard Test Methods for Fire Tests of Building Construction and Materials*, 2020.

2.3.3 IAPMO Publications. International Association of Plumbing and Mechanical Officials, 4755 E. Philadelphia Street, Ontario, CA 91761.

Uniform Plumbing Code, 2021.

2.3.4 ICC Publications. International Code Council, 500 New Jersey Avenue, NW, 6th Floor, Washington, DC 20001.

International Plumbing Code, 2021.

2.3.5 IEEE Publications. IEEE, 3 Park Avenue, 17th Floor, New York, NY 10016-5997.

IEEE C2, *National Electrical Safety Code*, 2017.

2.3.6 NERC Publications. North American Electric Reliability Corporation, 1325 G Street, NW, Suite 600, Washington, DC 20005.

PRC-005-6, *Protection System, Automatic Reclosing, and Sudden Pressure Relaying Maintenance*, 2016.

2.3.7 UL Publications. Underwriters Laboratories Inc., 333 Pfingsten Road, Northbrook, IL 60062-2096.

UL 263, *Fire Tests of Building Construction and Materials*, 2021.

UL 790, *Standard Test Methods for Fire Tests of Roof Coverings*, 2018.

UL 1012, *Power Units Other Than Class 2*, 2021.

UL 1741, *Inverters, Converters, Controllers and Interconnection System Equipment for Use With Distributed Energy Resources*, 2021.

UL 1778, *Uninterruptible Power Systems*, 2017.

UL 1973, *Batteries for Use in Stationary, Vehicle Auxiliary Power and Light Electric Rail (LER) Applications*, 2018.

UL 1974, *Evaluation for Repurposing Batteries*, 2018.

UL 9540, *Energy Storage Systems and Equipment*, 2020.

UL 9540A, *Test Method for Evaluating Thermal Runaway Fire Propagation in Battery Energy Storage Systems*, 2019.

UL 60950-1, *Information Technology Equipment — Safety — Part 1: General Requirements*, 2007, revised 2019.

UL 62368-1, *Audio/Video, Information and Communication Technology Equipment — Part 1: Safety Requirements*, 2021.

2.3.8 Other Publications.

Merriam-Webster's Collegiate Dictionary, 11th edition, Merriam-Webster, Inc., Springfield, MA, 2003.

2.4 References for Extracts in Mandatory Sections.

NFPA 30, *Flammable and Combustible Liquids Code*, 2021 edition.

NFPA 70®, *National Electrical Code®*, 2023 edition.

NFPA 72®, *National Fire Alarm and Signaling Code®*, 2022 edition.

NFPA 101®, *Life Safety Code®*, 2021 edition.

NFPA 111, *Standard on Stored Electrical Energy Emergency and Standby Power Systems*, 2022 edition.

Chapter 3 Definitions

3.1 General. The definitions contained in this chapter shall apply to the terms used in this standard. Where terms are not defined in this chapter or within another chapter, they shall be defined using their ordinarily accepted meanings within the context in which they are used. *Merriam-Webster's Collegiate Dictionary*, 11th edition, shall be the source for the ordinarily accepted meaning.

3.2 NFPA Official Definitions.

3.2.1* Approved. Acceptable to the authority having jurisdiction.

3.2.2* Authority Having Jurisdiction (AHJ). An organization, office, or individual responsible for enforcing the requirements of a code or standard, or for approving equipment, materials, an installation, or a procedure.

3.2.3 Labeled. Equipment or materials to which has been attached a label, symbol, or other identifying mark of an organization that is acceptable to the authority having jurisdiction and concerned with product evaluation, that maintains periodic inspection of production of labeled equipment or materials, and by whose labeling the manufacturer indicates compliance with appropriate standards or performance in a specified manner.

3.2.4* Listed. Equipment, materials, or services included in a list published by an organization that is acceptable to the authority having jurisdiction and concerned with evaluation of products or services, that maintains periodic inspection of production of listed equipment or materials or periodic evaluation of services, and whose listing states that either the equipment, material, or service meets appropriate designated standards or has been tested and found suitable for a specified purpose.

3.2.5 Shall. Indicates a mandatory requirement.

3.2.6 Standard. An NFPA standard, the main text of which contains only mandatory provisions using the word "shall" to indicate requirements and that is in a form generally suitable for mandatory reference by another standard or code or for adoption into law. Nonmandatory provisions are not to be considered a part of the requirements of a standard and shall be located in an appendix, annex, footnote, informational note, or other means as permitted in the NFPA manuals of style. When used in a generic sense, such as in the phrases "standards development process" or "standards development activities," the term "standards" includes all NFPA standards, including codes, standards, recommended practices, and guides.

3.3 General Definitions.

Δ 3.3.1* Apartment Building. A building or portion thereof containing three or more dwelling units with independent cooking and bathroom facilities. [101, 2021]

Δ 3.3.2 Battery. One or more cells connected together electrically in series, parallel, or both, to provide the required operating voltage and current levels.

3.3.2.1* Flow Battery. A type of storage battery that includes one or more electrolyte solutions or suspensions in at least one storage tank, one or more energy converters where chemical energy is converted into electrical energy in a reversible process, and a circulation system that causes electrolyte to flow between the tank(s) and converter(s).

3.3.3* Battery Management System (BMS). A system that monitors, controls, and optimizes performance of an individual or multiple battery modules.

3.3.4 Cell. The basic electrochemical unit, characterized by an anode and a cathode, used to receive, store, and deliver electrical energy. [70:100]

Δ 3.3.5 Dwelling Unit. One or more rooms arranged for complete, independent housekeeping purposes with space for eating, living, and sleeping; facilities for cooking; and provisions for sanitation. [101, 2021]

Δ 3.3.5.1* One- and Two-Family Dwelling Unit. A building that contains not more than two dwelling units with independent cooking and bathroom facilities. [101, 2021]

Δ 3.3.5.2 One-Family Dwelling Unit. A building that consists solely of one dwelling unit with independent cooking and bathroom facilities. [101, 2021]

Δ 3.3.5.3 Two-Family Dwelling Unit. A building that consists solely of two dwelling units with independent cooking and bathroom facilities. [101, 2021]

Δ 3.3.6 Electric Utilities. All enterprises engaged in the production or distribution of electricity for public use, including those that are typically designated or recognized by governmental law or regulation by public service/utility commissions and that install, operate, and maintain electric supply such as generation, transmission, or distribution systems.

3.3.7* Electrochemical Double Layer Capacitor (EDLC). A capacitor that has liquid electrolyte (e.g., acetonitrile) and electrodes with a highly porous surface that increases the surface area for holding charge resulting in much larger capacitance and energy density.

- △ 3.3.8* **Energy Storage Management System (ESMS).** A system that monitors, controls, and optimizes the performance and safety of an energy storage system.
- △ 3.3.9* **Energy Storage Systems (ESS).** One or more devices, assembled together, capable of storing energy to supply electrical energy at a future time.
- 3.3.9.1 **Capacitor Energy Storage System.** An electrical energy storage system using capacitors as a storage media.
- 3.3.9.1.1* **Electrochemical Energy Storage System.** An energy storage system that converts and stores chemical energy to electrical energy and vice versa.
- 3.3.9.1.2* **Mechanical Energy Storage System.** An energy storage system that converts and stores mechanical energy to electrical energy and vice versa.
- △ 3.3.9.2 **Energy Storage System Cabinet.** An enclosure containing components of the energy storage system where personnel cannot enter the enclosure other than reaching in to access components for maintenance purposes.
- △ 3.3.9.3 **Energy Storage System (ESS) Dedicated-Use Building.** A building that is only used for energy storage, or energy storage in conjunction with energy generation, electrical grid-related operations, or communications utility equipment.
- △ 3.3.9.4 **Energy Storage System Walk-In Unit.** A structure containing energy storage systems that includes doors that provide walk-in access for personnel to maintain, test, and service the equipment and is typically used in outdoor and mobile energy storage system applications.
- 3.3.9.5 **Mobile Energy Storage System.** An energy storage system capable of being moved and utilized as a temporary source of power.
- 3.3.9.6 **Portable Energy Storage System.** An energy storage system suitable to be lifted and moved by a single person without mechanical aids and not permanently connected to an electrical system.
- 3.3.9.7 **Stationary Energy Storage System.** An energy storage system that is permanently installed as fixed equipment.
- 3.3.10 **Fire and Explosion Testing.** Testing of a representative energy storage system that evaluates the fire and explosion hazards produced by a propagating thermal runaway.
- 3.3.11 **Fire Area.** An area of a building separated from the remainder of the building by construction having a fire resistance of at least 1 hour and having all communicating openings properly protected by an assembly having a fire resistance rating of at least 1 hour. [30, 2021]
- △ 3.3.12 **Fire Command Center.** The principal attended or unattended room or area where the status of the detection, alarm communications, control systems, and other emergency systems is displayed and from which the system(s) can be manually controlled. [72, 2022]
- N 3.3.13* **Flywheel Energy Storage System (FESS).** A mechanical energy storage system composed of a spinning mass referred to as a rotor and an energy conversion mechanism that converts the stored mechanical energy to electrical energy.
- N 3.3.13.1* **Braking.** Actively removing speed from the rotor without feeding power to the input or output.
- N 3.3.13.2* **Spin Down.** A shutdown condition of the FESS, where energy is being dissipated and the flywheel rotor is slowing down to a stop.
- N 3.3.13.3 **Standby FESS.** A condition of the flywheel energy storage system where the flywheel is rotating but not providing energy to external loads.
- 3.3.14 **Hazard Mitigation Analysis (HMA).** An evaluation of potential energy storage system failure modes and the safety-related consequences attributed to the failures.
- △ 3.3.15 **Living Area.** Any normally occupiable space in a residential occupancy, other than sleeping rooms or rooms that are intended for combination sleeping/living, bathrooms, toilet compartments, kitchens, closets, halls, storage or utility spaces, and similar areas. [101, 2021]
- 3.3.16 **Maximum Stored Energy.** The quantity of energy storage permitted in a fire area prior to the area being considered a high hazard occupancy.
- 3.3.17 **Off-Gassing.** The event in which the cell case vents due to a rise in internal pressure of the cell.
- 3.3.18 **Off-Specification Battery or Cell.** A cell or battery that has been tested during the manufacturing quality control process and found not to be within the manufacturer's designed set of criteria for its intended use.
- 3.3.19 **Open Parking Garage.** A structure or portion of a structure with the openings on two or more sides that is used for the parking or storage of motor vehicles.
- △ 3.3.20 **Qualified Person.** One who has skills and knowledge related to the construction and operation of the electrical equipment and installations and has received safety training to recognize and avoid the hazards involved. [70:100]
- N 3.3.21 **Recycle.** The process of collecting and processing materials that would otherwise be turned into trash and turning them into new products.
- N 3.3.22* **Repurposed Battery.** A battery that was used in one application in the field that is subject to some level of analysis and reconfiguration for use in an ESS application.
- N 3.3.23 **Standby Power Application.** An energy storage system utilizing a battery that is intended to remain on continuous float charge or in a high state of charge to support an event necessitating a discharge.
- N 3.3.24 **Storage of Batteries.** The storage, keeping, or collecting of batteries for future use as needed, or for disposal; does not include batteries undergoing manufacture or testing.
- N 3.3.25 **Stored-Energy Emergency Power Supply System (SEPESS).** A system consisting of a UPS, a rectifier plant, or a motor generator powered by a stored electrical energy source; a transfer switch designed to monitor preferred and alternate load power source and provide desired switching of the load; and all necessary control equipment to make the system functional. [111, 2022]
- △ 3.3.26* **Thermal Runaway.** Self-heating of an electrochemical system in an uncontrollable fashion.
- 3.3.27 **Utility Interactive.** An energy storage system intended for use in parallel with an electric utility to supply common loads that can deliver power to the utility.

Chapter 4 General

4.1* General. The design, construction, and installation of ESS and related equipment shall comply with Chapter 4 and as supplemented or modified by the technology-specific provisions in Chapters 9 through 13.

4.2 Construction Documents.

4.2.1 General.

4.2.1.1 The plans and specifications associated with an ESS and its intended installation, replacement or renewal, commissioning, and use shall be submitted to the AHJ for approval and include the following:

- (1) Location and layout diagram of the room or area in which the ESS is to be installed
- (2) Details on hourly fire-resistant-rated assemblies provided or relied upon in relation to the ESS
- (3) The quantities and types of ESS units
- (4) Manufacturer's specifications, ratings, and listings of ESS
- (5) Description of energy storage management systems and their operation
- (6) Location and content of required signage
- (7) Details on fire suppression, smoke or fire detection, gas detection, thermal management, ventilation, exhaust, and deflagration venting systems, if provided
- (8) Support arrangement associated with the installation, including any required seismic support

4.2.1.2 Plans and specifications associated with energy storage systems owned and operated by utilities as a component of the electric grid that are considered critical infrastructure documents, in accordance with the provisions of North American Electric Reliability Corporation and other applicable governmental laws and regulations shall be made available to the AHJ for viewing based on the requirements of the applicable governmental laws and regulations.

4.2.1.3 The following test data, evaluation information, and calculations shall be provided in addition to the plans and specifications in 4.2.1.1 where required elsewhere in this standard:

- (1) Fire and explosion testing data in accordance with 9.1.5
- (2) Hazard mitigation analysis (HMA) in accordance with Section 4.4
- (3) Calculations or modeling data to determine compliance with NFPA 68 and NFPA 69 in accordance with 9.6.5.6.3
- (4) Other test data, evaluation information, or calculations as required elsewhere in this standard

4.2.1.4 If modeling data is provided, validation of the modeling results shall also be included.

4.2.2 Building Owner. The construction documents described in this section shall be provided to the building owner or the owner's authorized agent prior to the system being put in service.

4.2.3 Manuals. An operations and maintenance manual shall be provided to both the ESS owner or their authorized agent and system operator before the system is put into operation and includes the following:

- (1) Submittal data stating the ESS size and selected options for each component of the system
- (2) Manufacturer's operation manuals and maintenance manuals for the entire ESS or for each component of the

system requiring maintenance that clearly identify the required routine maintenance actions

- (3)* Contact information for a contracted service agency or responsible in-house personnel
- (4) A narrative of how the ESS and its components and controls are intended to operate, including recommended operational set points
- (5) A service record log that lists the schedule for all required service and maintenance actions with space for logging such actions that can be completed over time

4.2.3.1 The operations and maintenance manual shall be prepared prior to final approval of the ESS and be readily accessible to personnel responsible for the ESS.

4.2.3.2 A copy of the operations and maintenance manual shall be placed in an approved location to be accessible to AHJs and emergency responders.

4.2.4 Commissioning Plan. A commissioning plan meeting the provisions of Chapter 6 shall be provided to the building owner or their authorized agent and the AHJ.

4.3 Emergency Planning and Training.

4.3.1* General. For ESS installations that exceed the maximum stored energy limits of Table 9.4.1, emergency planning and training shall be provided by the owner of the ESS or their authorized representative so that ESS facility operations and maintenance personnel and emergency responders can address foreseeable hazards associated with the on-site systems.

4.3.2 Facility Staff Planning and Training. For ESS installations that exceed the maximum stored energy limits of Table 9.4.1, an emergency operations plan and associated training shall be established, maintained, and conducted by ESS facility operations and maintenance personnel.

4.3.2.1 Emergency Operations Plan.

4.3.2.1.1 An emergency operations plan shall be readily available for use by facility operations and maintenance personnel.

4.3.2.1.2 For normally occupied facilities, the emergency operations plan shall be on site.

4.3.2.1.3 The plan shall be updated when conditions that affect the response considerations and procedures change.

4.3.2.1.4 The emergency operations plan shall include the following:

- (1) Procedures for safe shutdown, de-energizing, or isolation of equipment and systems under emergency conditions to reduce the risk of fire, electric shock, and personal injuries, and for safe start-up following cessation of emergency conditions
- (2) Procedures for inspection and testing of associated alarms, interlocks, and controls
- (3)* Procedures to be followed in response to notifications of system alarms or out-of-range conditions that could signify potentially dangerous conditions, including shutting down equipment, summoning service or repair personnel, and providing agreed-upon notification to fire department personnel, if required
- (4)* Emergency procedures to be followed in case of fire, explosion, release of liquids or vapors, damage to critical moving parts, or other potentially dangerous conditions

- (5) Response considerations similar to a safety data sheet (SDS) that will address response safety concerns and extinguishment when an SDS is not required
- (6) Procedures for dealing with ESS equipment damaged in a fire or other emergency event, including contact information for personnel qualified to safely remove damaged ESS equipment from the facility
- (7) Other procedures as determined necessary by the AHJ to provide for the safety of occupants and emergency responders
- (8) Procedures and schedules for conducting drills of these procedures

4.3.2.1.5 The emergency operations plan in 4.3.2.1 shall not be required for electric utility facilities under the exclusive control of the electric utility located outdoors or in building spaces used exclusively for such installations.

4.3.2.2 Facility Staff Training.

4.3.2.2.1 Personnel responsible for the operation, maintenance, repair, servicing, and response of the ESS shall be trained in the procedures included in the emergency operations plan in 4.3.2.1.

4.3.2.2.2 Refresher training shall be conducted at least annually and records of such training retained in an approved manner.

4.4 Hazard Mitigation Analysis (HMA).

Δ 4.4.1* A hazard mitigation analysis shall be provided to the AHJ for review and approval where any of the following conditions are present:

- (1) Technologies not specifically addressed in Table 1.3 are provided
- (2) More than one ESS technology is provided in a single fire area where adverse interaction between the technologies is possible
- (3) Where allowed as a basis for increasing maximum stored energy as specified in 9.4.1.1 and 9.4.1.2
- (4) Where required by the AHJ to address a potential hazard with an ESS installation that is not addressed by existing requirements
- (5) Where required for existing lithium-ion ESS systems that are not UL 9540 listed in accordance with 9.2.2.1
- (6) Where required for outdoor lithium-ion battery ESS systems in accordance with 9.5.2.1

Δ 4.4.2 Failure Modes.

Δ 4.4.2.1* The hazard mitigation analysis shall evaluate the consequences of the following failure modes and others deemed necessary by the AHJ:

- (1) A thermal runaway or mechanical failure condition in a single ESS unit
- (2) Failure of an energy storage management system or protection system that is not covered by the product listing failure modes and effects analysis (FMEA)
- (3) Failure of a required protection system including, but not limited to, ventilation (HVAC), exhaust ventilation, smoke detection, fire detection, fire suppression, or gas detection

4.4.2.2 Only single failure modes shall be considered for each mode given in 4.4.2.1.

Δ 4.4.3 The AHJ shall be permitted to approve the hazard mitigation analysis as documentation of the safety of the ESS installation if the consequences of the analysis demonstrate the following:

- (1) Fires will be contained within unoccupied ESS rooms for the minimum duration of the fire resistance rating specified in 9.6.4.
- (2) Fires and products of combustion will not prevent occupants from evacuating to a safe location.
- (3) Deflagration hazards will be addressed by an explosion control or other system.

4.4.4 The hazard mitigation analysis shall be documented and made available to the AHJ and those authorized to design and operate the system.

4.4.5* Construction, equipment, and systems that are required for the ESS to comply with the hazard mitigation analysis shall be installed, tested, and maintained in accordance with this standard and the manufacturer's instructions.

4.5 Combustible Storage.

4.5.1 Combustible materials not related to the ESS shall not be stored in dedicated rooms, cabinets, or enclosures containing ESS equipment.

4.5.2 Combustible materials related to the ESS shall not be stored within 3 ft (0.9 m) from ESS equipment.

4.5.3 Combustible materials in occupied work centers shall not be stored within 3 ft (0.9 m) of ESS equipment.

4.5.4 Combustible materials in occupied work centers shall comply with Section 10.19 of NFPA 1 or other applicable fire codes.

4.5.5 Section 4.5 shall not apply to dwelling units.

4.6 Equipment.

4.6.1* **Listings.** ESS shall be listed in accordance with UL 9540, unless specifically exempted in other sections of this standard.

4.6.2 Repairs.

4.6.2.1 Repairs of ESS shall only be performed by qualified persons and documented in the maintenance, testing, and events log required in 4.2.3.

N 4.6.2.2 Where installed in an electrical substation or electrical power plant, repairs shall be documented in accordance with the operating practices adopted by the responsible electrical utility.

4.6.2.3 Repairs with other than identical or equivalent parts shall be considered a retrofit and comply with 4.6.3.

4.6.3 Retrofits.

4.6.3.1 Retrofits of ESS shall be approved and comply with the following unless modified in other sections:

- (1) Battery systems and modules and capacitor systems and modules shall be listed in accordance with UL 1973 and installed in accordance with the manufacturer's instructions.
- (2) ESS management and other monitoring systems shall be connected and installed in accordance with the manufacturer's instructions.

- (3) The overall installation shall continue to comply with UL 9540 listing requirements, where applicable.
- (4) Retrofits shall be documented in the maintenance, testing, and events log required in 4.2.3.
- Δ 4.6.3.2*** Changing out or retrofitting existing lead-acid or nickel-cadmium batteries shall be considered repairs when there is no increase in system size or capacity greater than 10 percent from the original design.
- N 4.6.3.3** Retrofitting of an ESS with a different ESS technology or chemistry shall be considered a replacement and comply with 4.6.4.
- 4.6.4 Replacements.**
- 4.6.4.1** Replacement of ESS shall be considered new ESS installations and comply with the provisions applicable to new ESS.
- 4.6.4.2** The ESS being replaced shall be decommissioned in accordance with Chapter 8.
- Δ 4.6.5 Reused Equipment.** Materials, equipment, and devices shall not be reused or reinstalled unless such elements have been reconditioned, tested, and placed in good and proper working condition and approved.
- 4.6.6 Increase in Power Rating or Maximum Stored Energy.**
- 4.6.6.1** A complete new ESS that is added to an existing installation of one or more systems shall be treated as a new system and meet the applicable requirements of this standard.
- 4.6.6.2** An increase in maximum stored energy or power rating to an existing ESS shall be considered a retrofit and comply with 4.6.3.
- N 4.6.6.3** Where the original ESS was approved for the addition of maximum stored energy or power over the life of the asset without adding a new technology or adding different components, and the protection systems were designed, built, and tested to handle the anticipated maximum energy or power, this installation of additional energy storage shall be considered a retrofit and comply with 4.6.3.
- 4.6.7 Environment.** The temperature, humidity, and other environmental conditions in which an ESS is located shall be maintained in accordance with the listing and the manufacturer's specifications.
- 4.6.8 Charge Controllers.**
- 4.6.8.1** Charge controllers shall be compatible with the battery or ESS manufacturer's electrical ratings and charging specifications.
- 4.6.8.2** Charge controllers shall be listed and labeled for the application or be provided as part of a listed ESS.
- 4.6.9 Inverters and Converters.**
- 4.6.9.1*** Inverters and converters shall be listed and labeled for the application.
- 4.6.9.2*** Only units listed and labeled for utility interactive system use and identified as interactive shall be allowed to operate in parallel with the electric utility power system.
- 4.6.10* Energy Storage Management System (ESMS).** Where required elsewhere in this standard, areas containing ESS shall be provided with an ESMS or BMS, unless modified in Chapters 9 through 13.
- 4.6.11* ESS Toxic and Highly Toxic Gas Release During Normal Use.** ESS shall not release toxic or highly toxic gases during normal charging, discharging, and use.
- 4.6.12 Enclosures.**
- 4.6.12.1** Enclosures shall be of noncombustible construction.
- 4.6.12.2** ESS electrical circuitry shall be within weatherproof enclosures marked with the environmental rating suitable for the type of exposure required by *NFPA 70*.
- 4.7 Installation.** ESS shall be installed in accordance with their listing, the manufacturer's installation instructions, and this standard.
- 4.7.1* Electrical Installation.** The electrical installation shall be in accordance with *NFPA 70* or IEEE C2 based on the location of the ESS in relation to and its interaction with the electrical grid.
- N 4.7.1.1** Lead-acid and nickel-cadmium battery systems less than 50 V ac, 60 V dc that are in telecommunications facilities for installations of communications equipment under the exclusive control of communications utilities and located outdoors or in building spaces used exclusively for such installations that are in compliance with *NFPA 76* shall not be required to comply with 4.7.1.
- N 4.7.1.2** Lead-acid and nickel-cadmium battery systems that are used for dc power for control of substations and control or safe shutdown of generating stations under the exclusive control of the electric utility and located outdoors or in building spaces used exclusively for such installations shall not be required to comply with 4.7.1.
- 4.7.2 Seismic Protection.** ESS shall be seismically braced in accordance with the local building code.
- 4.7.3 Design Loads.** The weight of the ESS and all associated equipment, components, and enclosure elements and their impact on the dead and live loads of the building or system foundation shall be in accordance with the local building code.
- 4.7.4* Signage.**
- 4.7.4.1** Approved signage shall be provided in the following locations:
- (1) On the front of doors to rooms or areas containing ESS or in approved locations near entrances to ESS rooms
 - (2) On the front of doors to outdoor occupiable ESS containers
 - (3) In approved locations on outdoor ESS that are not enclosed in occupiable containers or otherwise enclosed
- Δ 4.7.4.2*** The signage required in 4.7.4.1 shall be in compliance with ANSI Z535 and include the following information as shown in Figure 4.7.4.2:
- (1) "Energy Storage Systems" with symbol of lightning bolt in a triangle
 - (2) Type of technology associated with the ESS
 - (3) Special hazards associated as identified in Chapters 9 through 15
 - (4) Type of suppression system installed in the area of the ESS
 - (5) Emergency contact information

4.7.4.3 A permanent plaque or directory denoting the location of the disconnecting means for all ESS on or in the premises shall be installed at each service equipment location and at the location(s) of the system disconnect(s) for all ESS capable of being interconnected.

4.7.4.3.1 Energy storage located on property that is under the exclusive control of utilities, secured from public access, and in accordance with 90.2(D)(5) of *NFPA 70* shall not be required to comply with 4.7.4.3.

4.7.4.3.2 Lead-acid and nickel-cadmium battery systems less than 50 V ac or 60 V dc in telecommunications facilities that are covered by and in compliance with *NFPA 76* and secured from public access shall not be required to comply with 4.7.4.3.

4.7.4.4 Existing ESS shall be permitted to retain the signage required at installation except as modified by 4.7.4.5.

4.7.4.5 Existing ESS signage shall be updated to comply with the requirements for new ESS installations when the system is retrofitted or existing signs need to be replaced.

4.7.4.6 Battery and ESS cabinets in occupied work centers covered by 9.5.1.2.1 shall be provided with exterior signs that identify the manufacturer and model number of the system and electrical rating (voltage and current) of the contained system, and any relevant electrical, chemical, and fire hazard.

4.7.5 Impact Protection.

4.7.5.1 ESS shall be located or protected to prevent physical damage from impact where such risks are identified.

4.7.5.2 Vehicle impact protection consisting of guard posts or other approved means shall be provided where ESS are subject to impact by motor vehicles.

4.7.5.3* When guard posts are installed, they shall be designed as follows:

- (1) Posts shall be constructed of steel not less than 4 in. (100 mm) in diameter.
- (2) Posts shall be filled with concrete.
- (3) Posts shall be spaced not more than 4 ft (1.2 m) on center.
- (4) Posts shall be set not less than 3 ft (0.9 m) deep in a concrete footing of not less than 15 in. (380 mm) diameter.
- (5) The top of the posts shall be set not less than 3 ft (0.9 m) above ground.
- (6) Posts shall be located not less than 3 ft (0.9 m) from the ESS.

4.7.5.4* For residential garages, ESS shall not be installed in a location where subject to damage from impact by a motor vehicle.

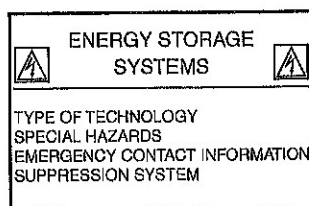

FIGURE 4.7.4.2 Example of ESS Signage.

4.7.6 Security of Installations.

4.7.6.1 ESS shall be secured against unauthorized entry and safeguarded in an approved manner.

4.7.6.2 Security barriers, fences, landscaping, and other enclosures shall not inhibit the required air flow to or exhaust from the ESS and its components.

4.7.7 Elevation. ESS shall be located only on floors that can be accessed by external fire department laddering capabilities unless a higher location is approved by the AHJ.

4.7.7.1 Belowgrade Installations.

4.7.7.1.1 ESS installations where the floor level is below the finished floor of the lowest level of exit discharge shall not be permitted unless the location is approved by the AHJ.

4.7.7.1.2 The ESS shall not be located inside an electrical room.

4.7.7.1.3 The ESS shall be accessible to emergency responders without traversing through an electrical room.

4.7.7.1.4 When approved by the AHJ, ESS installations in underground vaults constructed in accordance with Part III of Article 450 of *NFPA 70* shall be permitted.

4.7.7.2 When approved by the AHJ, ESS installations on rooftops of buildings that do not obstruct fire department rooftop operations shall be permitted.

4.7.7.3 The requirements in 4.7.7 shall not apply to the following:

- (1)* Lead-acid and nickel-cadmium battery systems less than 50 V ac or 60 V dc in telecommunications facilities for installations of communications equipment under the exclusive control of communications utilities and located outdoors or in building spaces used exclusively for such installations that comply with *NFPA 76*
- (2)* Lead-acid and nickel-cadmium battery systems that are used for dc power for control of substations and control or safe shutdown of generating stations under the exclusive control of the electric utility and located outdoors or in building spaces used exclusively for such installations
- (3) Lead-acid battery systems utilized exclusively in uninterruptible power supplies listed for their application and used for standby power applications, and limited to not more than 10 percent of the floor area on the floor on which the ESS is located

4.7.8 Means of Egress.

4.7.8.1 All areas containing ESS shall provide egress from the area in which they are located in accordance with the local building code.

4.7.8.2 Required egress doors shall be provided with emergency lighting as required by the local building code.

4.7.8.3 Required egress door(s) shall open in the direction of egress.

4.7.8.4 Required egress doors shall be equipped with listed panic hardware.

4.7.9 Open Rack Installations. Where installed in a room accessible only to authorized personnel, ESS shall be permitted to be installed on an open rack.

4.7.10 Fire Command Centers. In buildings containing ESS and equipped with a fire command center, the command center shall include signage or readily available documentation that describes the location and type of ESS, operating voltages, and location of electrical disconnects as required by *NFPA 70*.

4.7.11 Access Roads. Fire department access roads shall be provided to outdoor ESS installations in accordance with the local fire code.

4.7.12* Hazardous (Classified) Locations. The ESS shall not be located in a classified area as defined in *NFPA 70* or *IEEE C2* unless listed and approved for the specific installation.

4.7.13 Fire Barriers. Rooms or spaces containing ESS shall be separated from other areas of the building by fire barriers with a minimum 2-hour fire resistance rating and horizontal assemblies with a minimum 2-hour fire resistance rating and constructed in accordance with the local building code, unless modified in Chapters 9 through 13.

4.8 Smoke and Fire Detection.

4.8.1* Where required elsewhere in this standard, areas containing ESS systems shall be provided with a smoke detection or radiant energy-sensing system in accordance with *NFPA 72*, unless modified by the requirements in Chapters 9 through 13.

4.8.1.1* Normally unoccupied, remote standalone telecommunications structures with a gross floor area of less than 1500 ft² (139 m²) using lead-acid or nickel-cadmium battery technology shall not be required to have the detection required in 4.8.1.

4.8.1.2* Lead-acid and nickel-cadmium battery systems that are used for dc power for control of substations and control or safe shutdown of generating stations under the exclusive control of the electric utility and located outdoors or in building spaces used exclusively for such installations shall be allowed to use the process control system to monitor the smoke detectors required in 4.8.1.

4.8.2 Annunciation.

4.8.2.1 All required annunciation means shall be located as required by the authority having jurisdiction to facilitate an efficient response to the situation. [72:10.18.3.2]

4.8.2.2* Multiple panels shall be aggregated to a master or annunciator panel at a location approved by the AHJ.

4.8.3* Smoke and fire detection systems protecting an ESS with lithium-ion batteries shall be required to provide a secondary power supply in accordance with *NFPA 72* capable of 24 hours in standby and 2 hours in alarm.

4.8.4 Alarm signals from detection systems shall be transmitted to a supervising station in accordance with *NFPA 72*.

4.9 Fire Control and Suppression.

4.9.1* Where required elsewhere in this standard, fire control and suppression for rooms or areas within buildings and outdoor walk-in units containing ESS shall be provided in accordance with this section, unless modified in Chapters 9 through 13.

4.9.1.1* Lead-acid and nickel-cadmium battery systems less than 50 V ac, 60 V dc that are in telecommunications facilities for installations of communications equipment under the

exclusive control of communications utilities and located outdoors or in building spaces used exclusively for such installations that comply with *NFPA 76* shall not be required to have a fire suppression system installed.

4.9.1.2 Lead-acid battery systems in uninterruptible power supplies listed and labeled in accordance with the application utilized for standby power applications, which is limited to not more than 10 percent of the floor area on the floor on which the ESS is located, shall not be required to have a fire suppression system installed.

4.9.1.3* Lead-acid and nickel-cadmium battery systems that are used for dc power for control of substations and control or safe shutdown of generating stations under the exclusive control of the electric utility and located outdoors or in building spaces used exclusively for such installations shall not be required to have a fire suppression system installed.

4.9.1.4 When approved by the AHJ, ESS shall be permitted to be installed in open parking garages without the protection of an automatic fire suppression system where fire, explosion, and fault condition testing documents the system does not present an exposure hazard to parked vehicles when installed in accordance with manufacturer's instructions and this standard.

4.9.1.5 When approved by the AHJ, ESS shall be permitted to be installed in ESS dedicated-use buildings without the protection of an automatic fire control and suppression system where fire and explosion testing conducted in accordance with 9.1.5 documents that an ESS fire does not compromise the means of egress and does not present an exposure hazard to buildings, lot lines, public ways, stored combustible materials, hazardous materials, high-piled stock, and other exposure hazards not associated with electrical grid infrastructure.

4.9.1.6 When approved by the AHJ, ESS shall be permitted to be installed in outdoor walk-in enclosures without the protection of an automatic fire control and suppression system where fire and explosion testing conducted in accordance with 9.1.5 documents that an ESS fire does not compromise the means of egress and does not present an exposure hazard in accordance with 9.5.2.6.1 and 9.5.2.6.1.7.

4.9.2 Sprinkler System. Sprinkler systems shall be installed in accordance with *NFPA 13* or equivalent.

4.9.2.1 Sprinkler systems for ESS units (groups) with a maximum stored energy of 50 kWh, as described in 9.4.2.1, shall be designed using a minimum density of 0.3 gpm/ft² (12.2 mm/min) based over the area of the room or 2500 ft² (230 m²) design area, whichever is smaller, unless a lower density is approved based upon fire and explosion testing in accordance with 9.1.5.

4.9.2.2* Sprinkler systems for ESS units (groups) exceeding 50 kWh shall use a density based on fire and explosion testing in accordance with 9.1.5.

4.9.3 Alternate Automatic Fire Control and Suppression Systems.

4.9.3.1* Other automatic fire control and suppression systems shall be permitted based on reports issued as a result of fire and explosion testing in accordance with 9.1.5.

4.9.3.2* The automatic fire control and suppression systems shall comply with the following standards, or their equivalent, as appropriate:

- (1) NFPA 12
- (2) NFPA 15
- (3) NFPA 750
- (4) NFPA 770
- (5) NFPA 2001
- (6) NFPA 2010

4.9.4 Water Supply.

4.9.4.1* Where required elsewhere in this standard, sites where nonmechanical ESS are installed shall be provided with a permanent source of water for fire protection, unless modified in Chapters 9 through 13.

4.9.4.2 Where no permanent adequate and reliable water supply exists for firefighting purposes, the requirements of NFPA 1142 shall apply.

4.9.4.3 Accessible fire hydrants shall be provided for site ESS installations where a public or private water supply is available.

4.9.4.4 Fire hydrants installed on private fire service mains shall be installed in accordance with NFPA 24 or equivalent local requirement where NFPA 24 is not adopted.

N 4.10 Mobile ESS Equipment and Operations. Mobile ESS equipment and operations shall comply with 9.5.3.2, as applicable.

Chapter 5 System Interconnections

5.1 General. System interconnections shall comply with Section 5.2 through Section 5.4, as applicable.

Δ 5.2 Disconnecting Means. A readily accessible disconnecting means for the ESS shall be provided.

N 5.2.1 Lead-acid and nickel-cadmium battery systems less than 60 V dc shall not be required to comply with Section 5.2.

N 5.2.2 Lead-acid and nickel-cadmium battery systems that are used for dc power for control of substations and control or safe shutdown of generating stations under the exclusive control of the electric utility and located outdoors or in building spaces used exclusively for such installations shall not be required to comply with Section 5.2.

5.3 Nonelectrical Systems.

Δ 5.3.1 Natural Gas. Piping, valves, and fittings from the outlet of the supplier's piping to the outlet of the ESS shutoff valve shall be in accordance with NFPA 54.

5.3.2 Compressed Natural Gas (CNG). The design, location, and installation of piping, valves, and fittings from the outlet of the point of delivery from the supplier to the inlets of the equipment shutoff valves shall be in accordance with NFPA 52.

5.3.3 Liquefied Petroleum Gas (LP-Gas) Systems and Storage. The design, location, and installation of liquefied petroleum gas (LP-Gas) storage and piping systems shall comply with NFPA 58.

5.3.4 Hydrogen Fuel Systems and Storage. The design, location, and installation of hydrogen gas and liquid hydrogen storage and piping systems shall comply with NFPA 2.

5.3.5 Biogas. Storage tanks and their associated equipment, piping, valves, and regulators shall be designed and installed in accordance with NFPA 54.

5.3.6 Liquid Fuels. The design of liquid fuel piping systems and the location and storage of liquid fuels shall be in accordance with NFPA 30.

Δ 5.3.7 Water. Where the ESS requires a permanent water supply to operate, it shall be provided through a connection to an on-site water supply in accordance with ICC's *International Plumbing Code*, IAPMO's *Uniform Plumbing Code*, or local regulations; or through a self-contained water source.

• 5.4* Support Systems. All connections to and from an ESS or the components of an ESS to required plumbing, fire alarm, detection, or control circuits or to ventilation systems shall be in accordance with nationally recognized standards applicable to those systems, manufacturer's instructions, listings, and the applicable provisions of Chapters 4 and 5.

Chapter 6 Commissioning

6.1 System Commissioning.

Δ 6.1.1 ESS shall be evaluated and confirmed for proper operation by the system owner or their designated agent.

Δ 6.1.1.1 Lead-acid and nickel-cadmium battery systems less than 50 V ac, 60 V dc that are in telecommunications facilities for installations of communications equipment under the exclusive control of communications utilities and located outdoors or in building spaces or walk-in units used exclusively for such installations that comply with NFPA 76 shall be permitted to have a commissioning plan complying with recognized industry practices in lieu of complying with 6.1.5.2.

Δ 6.1.1.2* Lead-acid and nickel-cadmium battery systems that are used for dc power for control of substations and control or safe shutdown of generating stations under the exclusive control of the electric utilities and located in building spaces or walk-in units used exclusively for such installations shall be permitted to have a commissioning plan in accordance with applicable governmental laws and regulations in lieu of developing a commissioning plan in accordance with 6.1.5.2.

Δ 6.1.2 System commissioning shall be conducted after the installation is complete but prior to final inspection and approval.

N 6.1.3 Commissioning Plan.

6.1.3.1 The system installer or commissioning agent shall prepare a written commissioning plan that provides a description of the means and methods necessary to document and verify that the system and its associated controls and safety systems, as required by this standard, are in proper working condition.

Δ 6.1.3.2 The commissioning plan shall include, but not be limited to, the following information:

- (1) An overview of the commissioning process developed specifically for the ESS to be installed and narrative description of the activities to be conducted
- (2) Roles and responsibilities for all those involved in the design, commissioning, construction, installation, or operation of the system(s)

- (3) Means and methods whereby the commissioning plan will be made available during the implementation of the ESS project(s)
- (4) Plans and specifications necessary to understand the operation of the ESS and all associated operational controls and safety systems
- (5) A detailed description of each activity to be conducted during the commissioning process, who will perform each activity, and at what point in time the activity is to be conducted
- (6) Procedures to be used in documenting the proper operation of the ESS and all associated operational controls and safety systems
- (7) Testing for any required fire detection or suppression and thermal management, ventilation, or exhaust systems associated with the installation and verification of proper operation of the safety controls
- (8) The following documentation:
 - (a) Commissioning checklist
 - (b) Relevant operational testing forms
 - (c) Necessary commissioning logs
 - (d) Progress reports
- (9) Means and methods whereby facility operation and maintenance staff will be trained on the system
- (10) Identification of personnel who are qualified to service and maintain the system and respond to incidents involving each system
- (11) A decommissioning plan meeting the provisions of Section 8.1 that covers the removal of the system from service and from the facility in which it is located and information on disposal of materials associated with each ESS

6.1.4 Commissioning Test.

6.1.4.1 ESS shall be evaluated for their proper operation by the system installer in accordance with the manufacturer's instructions, the commissioning plan, and the requirements of this section after the installation is complete but prior to final approval.

6.1.4.2 System testing shall be conducted as a component of the commissioning process and include functional performance testing of the ESS that demonstrates that the installation and operation of the system and associated components, controls, and safety-related systems are in accordance with approved plans and specifications and that the operation, function, and maintenance serviceability for each of the commissioned ESS is confirmed.

N 6.1.5 Commissioning Report.

Δ 6.1.5.1 The commissioning report shall be provided by the system installer or commissioning agent to the system(s) owner and the AHJ prior to final inspection and approval.

Δ 6.1.5.2 The commissioning report shall document the commissioning process and the results in accordance with 6.1.5.2.1, 6.1.5.2.2, and 6.1.5.2.3.

Δ 6.1.5.2.1 A commissioning report shall summarize the commissioning process and verify the proper operation of the system and associated operational controls and safety systems.

6.1.5.2.2 The report shall include the final commissioning plan, the results of the commissioning process, and a copy of

the plans and specifications associated with the as-built system design and installation.

6.1.5.2.3 The report shall include any issues identified during commissioning and the measures taken to resolve them.

N 6.1.5.3 Corrective Action Plan.

6.1.5.3.1 A corrective action plan acceptable to the AHJ shall be developed for any open or continuing issues that are allowed to be continued after commissioning.

N 6.1.5.3.2 The corrective action plan shall be accepted by the AHJ prior to the ESS being placed into service.

N 6.1.5.4 A copy of the commissioning report shall be kept with the ESS operations and maintenance manuals required by 4.2.3.

6.2 Issues and Resolutions Documentation. (Reserved)

6.3 Operations and Maintenance Documentation.

6.3.1 Operations and maintenance documentation shall be provided to the ESS owner.

6.3.2 The documentation shall include design, construction, installation, testing, and commissioning information associated with the ESS as initially approved after being commissioned.

6.3.3 A copy of the documentation shall be placed in an approved location to be accessible to facility personnel, fire code officials, and emergency responders.

6.4* Recommissioning of Existing Systems.

6.4.1 Recommissioning shall meet the provisions of Section 6.1 and include the entire system with issuance of a new commissioning report, identification of any new issues and resolutions documentation, and identification of any revisions to the operations and maintenance documentation.

6.4.2* When alterations, additions, repositioning, or renovations to the system or any of its components are warranted, they shall be permitted in accordance with Chapter 4 and be performed by qualified entities and the system recommissioned in accordance with Section 6.1.

6.4.3 Repairs or renewals to systems utilizing identical components shall not require recommissioning.

6.4.4* Listed ESS that has been modified in the field beyond the field-installed options that are part of the listing shall be investigated and found suitable by the organization that listed the equipment.

Chapter 7 Operation and Maintenance

7.1 System Operation. All ESS shall be operated in accordance with the manufacturer's instructions and the operation and maintenance documentation.

7.1.1 Electric Utilities Under NERC Jurisdiction.

7.1.1.1 Electric utilities under NERC jurisdiction shall comply with NERC PRC-005 requirements.

Δ 7.1.1.2 Electric utilities under NERC jurisdiction shall not be required to follow manufacturer's instructions for lead-acid and nickel-cadmium battery systems that are used for dc power for control of substations and control or safe shutdown of

generating stations under the exclusive control of the electric utility and located outdoors or in building spaces used exclusively for such installations.

▲ 7.1.2 The operation and maintenance documentation shall include the following:

- (1) Procedures for the safe startup of the ESS system and associated equipment
- (2) Procedures for inspection and testing of associated alarms, interlocks, and controls
- (3) Procedures for maintenance and operation of the following, where applicable:
 - (a) Energy storage management systems (ESMS)
 - (b) Fire protection equipment and systems
 - (c) Spill control and neutralization systems
 - (d) Exhaust and ventilation equipment and systems
 - (e) Gas detection systems
 - (f) Other required safety equipment and systems
- (4) Response considerations similar to a safety data sheet (SDS) that address response safety concerns and extinguishment where an SDS is not required
- (5)* An instruction that equipment or system changes to the installation are required to be recorded by updating any engineering documentation

7.1.3 SDS for Hazardous Materials.

7.1.3.1 SDS for hazardous materials contained in the ESS shall be posted within sight of the disconnecting means of any ESS or at a location approved by the AHJ.

▲ 7.1.3.2 For ESS located outdoors, a means shall be provided to protect the SDS from the weather.

7.1.4 Where the operations and maintenance documentation calls for detailed procedures to be used for specific scheduled operational checks or assessments, an operations record that includes data associated with configurable system settings, system start-up, system shutdown (including emergency shutdown), and long-term shutdown (storage mode) shall be maintained by the system owner or their designated agent and be made available to the AHJ upon request.

• 7.1.5 The operations record shall be kept in a readily accessible location, or a sign indicating where the record is located shall be posted adjacent to the system.

▲ 7.1.5.1 For normally occupied facilities, the operations record shall be on site.

▲ 7.1.5.2 The operations record shall be permitted to be made available electronically.

7.2* **System Maintenance.** The ESS shall be maintained in accordance with the system manufacturer's instructions.

7.2.1 The maintenance documentation shall include a detailed maintenance schedule covering all affected equipment and the activities to be performed.

7.2.2 Maintenance shall be performed by qualified individuals.

7.2.3 Maintenance documentation indicating the maintenance action taken, the date of the action, who implemented the action, and the results associated with the action shall be maintained as required by Section 6.3.

7.2.4 Maintenance documentation shall record information on any repair, renewal, or renovation made to the ESS.

7.2.5 **Training.** Training shall be provided to all those responsible for system operation and maintenance.

7.2.5.1 Training on system operation and maintenance shall be provided by the system owner or their designated agent.

7.2.5.2 After recommissioning the system, training on any changes to the operation and maintenance documentation shall be provided.

7.2.5.3 Training records of site operations and maintenance personnel shall be retained and accessible to the AHJ, indicating the training taken, the name(s) of those taking the training, and the training date.

7.3 System Testing.

7.3.1 System testing shall be performed when required by the operating instructions or maintenance documentation in accordance with testing procedures provided by the ESS manufacturer.

7.3.2 A record of all testing shall be maintained in accordance with the requirements in Section 6.3.

▲ 7.3.2.1 Testing records shall be permitted to be made available electronically.

Chapter 8 Decommissioning

8.1 **Decommissioning Plan.** Prior to decommissioning, the owner of an ESS or their designated agent(s) shall prepare a written decommissioning plan complying with 8.1.3 that provides the organization, documentation requirements, and methods and tools necessary to indicate how the safety systems as required by this standard and the ESS and its components will be decommissioned and the ESS removed from the site.

▲ 8.1.1 Lead-acid and nickel-cadmium battery systems less than 50 V ac, 60 V dc that are in telecommunications facilities for installations of communications equipment under the exclusive control of communications utilities and located outdoors or in building spaces or walk-in units used exclusively for such installations that are in compliance with NFPA 76 shall be permitted to have a decommissioning plan in compliance with recognized industry practices in lieu of complying with 8.1.3.

▲ 8.1.2* Lead-acid and nickel-cadmium battery systems that are used for dc power for control of substations and control or safe shutdown of generating stations under the exclusive control of the electric utilities and located outdoors or in building spaces used exclusively for such installations shall be permitted to have a decommissioning plan complying with applicable governmental laws and regulations in lieu of complying with 8.1.3.

8.1.3* The decommissioning plan shall be provided to the AHJ and include the following information:

- (1) An overview of the decommissioning process developed specifically for the ESS that is to be decommissioned
- (2) Roles and responsibilities for all those involved in the decommissioning of the ESS and their removal from the site

- (3) Means and methods in the decommissioning plan submitted during the permitting process to be made available at a point in time corresponding to the decision to decommission the ESS
- (4) Plans and specifications necessary to understand the ESS and all associated operational controls and safety systems, as built, operated, and maintained
- (5) A detailed description of each activity to be conducted during the decommissioning process and who will perform that activity and at what point in time
- (6) Procedures to be used in documenting the ESS and all associated operational controls and safety systems that have been decommissioned
- (7) Guidelines and format for a decommissioning checklist and relevant operational testing forms and necessary decommissioning logs and progress reports
- (8) A description of how any changes to the surrounding areas and other systems adjacent to the ESS, including, but not limited to, structural elements, building penetrations, means of egress, and required fire detection and suppression systems, will be protected during decommissioning and confirmed as being acceptable after the system is removed

8.2 Decommissioning Process.

8.2.1 The AHJ shall be notified prior to decommissioning an ESS.

8.2.2 The ESS shall be decommissioned by the owner of the ESS or their designated agent(s) in accordance with the decommissioning plan.

8.3 Decommissioning Report. A decommissioning report shall be prepared by the ESS owner or their designated agent and summarize the decommissioning process of the system and associated operational controls and safety systems.

8.3.1 The report shall include the final decommissioning plan and the results of the decommissioning process.

8.3.2 The report shall include any issues identified during decommissioning and the measures taken to resolve them.

8.3.3 The decommissioning report shall be retained by the owner and provided to the AHJ upon request.

Chapter 9 Electrochemical Energy Storage Systems

9.1 General.

9.1.1* The requirements of this chapter shall apply to installations of electrochemical ESS, including, but not limited to, battery ESS and electrochemical double-layer capacitor (EDLC) ESS.

9.1.2 This chapter shall not apply to surge capacitors installed in accordance with Article 460 of *NFPA 70*.

9.1.3* This chapter shall not apply to capacitors and capacitor equipment for electric utilities and industrial facilities used in applications such as flexible ac transmission (FACTS) devices, filter capacitor banks, power factor correction, and standalone capacitor banks for voltage correction and stabilization.

9.1.4 Unless modified by this chapter, the requirements of Chapters 4 through 8 shall also apply.

9.1.5 Fire and Explosion Testing.

9.1.5.1* Where required elsewhere in this standard, fire and explosion testing in accordance with 9.1.5 shall be conducted on a representative ESS in accordance with UL 9540A or equivalent test standard.

9.1.5.1.1 Lead-acid and nickel-cadmium batteries used in standby power systems and listed to UL 1973 shall not require UL 9540A testing when they are installed with a charging system that is listed to UL 1012, UL 60950-1, or UL 62368-1, or a UPS listed to UL 1778.

9.1.5.1.2 The testing shall be conducted or witnessed and reported by an approved testing laboratory to characterize the composition of the gases generated and show that a fire involving one ESS unit will not propagate to an adjacent unit.

9.1.5.1.3* The representative cell, modules, and units tested, including any optional integral fire suppression system, shall match the intended installation configuration other than the addition of the cell failure mechanism utilized for cell thermal runaway initiation.

9.1.5.1.4 The testing shall include evaluation of deflagration mitigation measures when designed into ESS cabinets.

9.1.5.2* Test Reports.

9.1.5.2.1 The complete test report and its supporting data shall be provided to the AHJ for review and approval.

9.1.5.2.2 The test report shall be accompanied by a supplemental report prepared by a registered design professional with expertise in fire protection engineering that provides interpretation of the test data in relation to the installation requirements for the ESS.

9.2 Equipment.

9.2.1 Listing.

9.2.1.1 ESS shall be listed in accordance with UL 9540, unless specifically exempted elsewhere in this standard.

9.2.1.2 Lead-Acid and Nickel-Cadmium Battery Systems.

9.2.1.2.1* Lead-acid and nickel-cadmium batteries, where used in a stationary standby service with 600 V dc or less, shall be permitted to be listed to UL 1973.

9.2.1.2.2* Lead-acid and nickel-cadmium battery systems less than 50 V ac, 60 V dc in telecommunications facilities for installations of communications equipment under the exclusive control of communications utilities used in stationary standby service and located outdoors or in building spaces used exclusively for such installations that comply with *NFPA 76* shall not be required to be listed in accordance with UL 9540.

9.2.1.2.3* Lead-acid and nickel-cadmium battery systems that are used for dc power for control of substations and control or safe shutdown of generating stations under the exclusive control of the electric utility and located outdoors or in building spaces used exclusively for such installations shall not be required to be listed in accordance with UL 9540.

9.2.1.2.4 Lead-acid battery systems in uninterruptible power supplies listed and labeled in accordance with UL 1778 and utilized for standby power applications, which are limited to not more than 10 percent of the floor area on the floor on

which the ESS is located, shall not be required to be listed in accordance with UL 9540.

N 9.2.2 HMA for Existing Lithium-Ion ESS.

N 9.2.2.1 Existing lithium-ion ESS that are not UL 9540 listed shall require a hazard mitigation analysis in accordance with Section 4.4.

N 9.2.2.2 Lithium-ion ESS shall be upgraded with additional hazard mitigation measures where required by the AHJ based on the findings in the hazard mitigation analysis.

N 9.2.3 Energy Storage Management System (ESMS).

N 9.2.3.1* Where required by the equipment listing in accordance with 4.6.1 or the hazard mitigation analysis in accordance with Section 4.4, an approved ESMS or BMS shall be provided for monitoring operating conditions and maintaining voltages, currents, and temperatures within the manufacturer's specifications, unless modified in accordance with Chapters 9 through 13.

N 9.2.3.2* The ESMS or BMS shall electrically isolate the ESS or affected components of the ESS or place the system in a safe condition if potentially hazardous conditions are detected.

N 9.2.3.3* When required by the AHJ, visible annunciation shall be provided on the cabinet exterior or in an approved location to indicate potentially hazardous conditions associated with the ESS exist.

N 9.2.3.4 Lead-Acid and Nickel-Cadmium Battery Systems.

N 9.2.3.4.1* Lead-acid and nickel-cadmium battery systems less than 50 V ac, 60 V dc in telecommunications facilities for installations of communications equipment under the exclusive control of communications utilities located outdoors or in building spaces used exclusively for such installations that comply with NFPA 76 shall not be required to comply with 9.2.3.1 through 9.2.3.3.

N 9.2.3.4.2* Lead-acid and nickel-cadmium battery systems that are used for dc power for control of substations and control or safe shutdown of generating stations under the exclusive control of the electric utility and located outdoors or in building spaces used exclusively for such installations shall not be required to comply with 9.2.3.1 through 9.2.3.3.

N 9.2.3.4.3 Lead-acid and nickel-cadmium battery systems in uninterruptable power supplies listed and labeled in accordance with UL 1778 and used in standby power applications shall not be required to comply with 9.2.3.1 through 9.2.3.3.

N 9.2.4 Repurposed and Refurbished Batteries.

N 9.2.4.1 Batteries that have been repurposed or refurbished shall meet the applicable technology-specific requirements in Table 9.6.5.

N 9.2.4.2* Batteries previously used in other applications, such as electric vehicle propulsion, shall not be permitted unless the equipment is repurposed by a UL 1974-compliant battery repurposing company where reused in ESS applications and the system complies with 4.6.1.

N 9.3 Location Classification. Installation locations shall be classified as specified in 9.3.1 or 9.3.2.

N 9.3.1 Indoor Installations. Indoor installations shall be classified in accordance with 9.3.1.1 or 9.3.1.2.

N 9.3.1.1 Energy Storage System (ESS) Dedicated-Use Buildings. ESS dedicated-use buildings shall be constructed in accordance with local building codes and comply with all the following:

- (1) The building shall only be used for energy storage, or energy storage in conjunction with energy generation, electrical grid-related operations, or communications utility equipment.
- (2) Occupants in the rooms and areas containing ESS shall be limited to personnel that operate, maintain, service, test, and repair the ESS and other energy or communication systems.
- (3) No other occupancy types shall be permitted in the building.
- (4) Administrative and support personnel shall be permitted in incidental-use areas within the buildings that do not contain ESS if the following conditions are met:
 - (a) The areas do not occupy more than 10 percent of the building area of the story in which they are located.
 - (b) The areas are separated from the ESS and other rooms and areas containing ESS by 2-hour fire barriers and 2-hour fire-resistance-rated horizontal assemblies constructed in accordance with the local building code, as appropriate.
 - (c) A means of egress is provided from the incidental-use areas to a public way that does not require occupants to traverse through areas containing ESS or other energy systems.

N 9.3.1.2 Non-Dedicated-Use Buildings. Non-dedicated-use buildings shall include all buildings that contain ESS and do not comply with ESS dedicated-use building requirements in 9.3.1.1.

N 9.3.2 Outdoor Installations. Outdoor ESS installations shall be classified as follows:

- (1) *Remote locations:* ESS located more than 100 ft (30.5 m) from buildings, lot lines that can be built upon, public ways, stored combustible materials, hazardous materials, high-piled stock, and other exposure hazards not associated with electrical grid infrastructure
- (2) *Locations near exposures:* all outdoor ESS locations that do not comply with remote outdoor location requirements
- (3) Specific outdoor locations, as follows:
 - (1) *Rooftop installations:* ESS installations located on the roofs of buildings
 - (2) *Open parking garage installations:* ESS installations located in a structure or portion of a structure as defined in 3.3.19
 - (3) Mobile ESS installations

N 9.4 Installation.

N 9.4.1 Maximum Stored Energy. ESS in the following locations shall comply with Section 9.4 as follows:

- (1) Fire areas within non-dedicated-use buildings containing ESS shall not exceed the maximum stored energy values in Table 9.4.1 except as permitted by 9.4.1.1.
- (2) Outdoor ESS installations in locations near exposures shall not exceed the maximum stored energy values in Table 9.4.1 except as permitted by 9.4.1.2.
- (3) ESS installations in open parking garages and on rooftops of buildings shall not exceed the maximum stored energy values in Table 9.4.1 except as permitted by 9.4.1.2.

- (4) Mobile ESS equipment as covered by 9.5.3.2 shall not exceed the maximum stored energy values in Table 9.4.1 except as permitted by 9.4.1.2.

N 9.4.1.1 Where approved by the AHJ, fire areas in non-dedicated-use buildings containing ESS that exceed the amounts in Table 9.4.1 shall be permitted based on a hazard mitigation analysis in accordance with Section 4.4 and fire and explosion testing complying with 9.1.5.

N 9.4.1.2 Where approved by the AHJ, outdoor ESS installations, ESS installations in open parking garages and on rooftops of buildings, and mobile ESS equipment that exceed the amounts in Table 9.4.1 shall be permitted based on a hazard mitigation analysis in accordance with Section 4.4 and fire and explosion testing in accordance with 9.1.5.

N 9.4.1.3 Where a single fire area within a building or walk-in unit contains a combination of energy systems covered in Table 9.4.1, the maximum stored energy per fire area shall be determined based on the sum of percentages of each type divided by the maximum stored energy of each type.

N 9.4.1.4 The sum of the percentages calculated in 9.4.1.3 shall not exceed 100 percent except as permitted in 9.4.1.1 or 9.6.2.3.

N 9.4.2* Size and Separation.

N 9.4.2.1 ESS shall be comprised of groups with a maximum stored energy of 50 kWh each.

N 9.4.2.2 Each group shall be spaced a minimum 3 ft (0.9 m) from other groups and from walls in the storage room or area.

N 9.4.2.3 The AHJ shall be permitted to approve groups with larger energy capacities or smaller group spacing based on performance criteria from fire and explosion testing complying with 9.1.5.

N 9.4.2.4 Lead-Acid and Nickel-Cadmium Battery Systems.

N 9.4.2.4.1* Paragraphs 9.4.2.1 and 9.4.2.2 shall not apply to lead-acid and nickel-cadmium battery systems less than 50 V ac, 60 V dc in telecommunications facilities that comply with NFPA 76.

N 9.4.2.4.2* Paragraphs 9.4.2.1 and 9.4.2.2 shall not apply to lead-acid and nickel-cadmium battery systems that are used for dc power for control of substations and control or safe shutdown of generating stations under the exclusive control of the electric utility and located outdoors or in building spaces used exclusively for such installations.

N 9.4.2.4.3 Paragraphs 9.4.2.1 and 9.4.2.2 shall not apply to lead-acid battery systems in uninterruptible power supplies listed and labeled in accordance with UL 1778, utilized for standby power applications, which is limited to not more than 10 percent of the floor area on the floor on which the ESS is located.

N 9.4.2.4.4 Lead-acid and nickel-cadmium batteries listed to UL 1973 and used in stationary standby applications shall be comprised of groups with a maximum stored energy of 250 kWh each.

N 9.5 Location and Applications.

N 9.5.1 Indoor Installations. Indoor ESS installations shall comply with this section and as detailed in Table 9.5.1.

N 9.5.1.1 ESS Dedicated Use Buildings.

N 9.5.1.1.1 Where approved by the AHJ, the fire control and suppression systems, the size and separation requirements, and the water supply shall be permitted to be omitted in ESS dedicated-use buildings located more than 100 ft (30.5 m) from buildings, lot lines that can be built upon, public ways, stored combustible materials, hazardous materials, high-piled stock, and other exposure hazards not associated with electrical grid infrastructure.

N 9.5.1.1.2 When approved, alarm signals shall not be required to be transmitted to an approved location when local fire alarm annunciation is provided and trained personnel are always present.

N Table 9.5.1 Indoor ESS Installations

Compliance Required	ESS Dedicated-Use Buildings	Non-Dedicated-Use Buildings	Reference
Administrative	Yes	Yes	Chapters 1-3
General	Yes	Yes	Sections 4.1-4.7
Size and separation	Yes	Yes	9.4.2
Maximum stored energy	No	Yes	9.4.1
Elevation	Yes	Yes	4.7.7
Fire barriers	NA	Yes	9.6.4
Smoke and fire detection	Yes	Yes	9.6.1
Fire control and suppression	Yes	Yes	9.6.2
Water supply	Yes	Yes	9.6.3
Signage	Yes	Yes	4.7.4
Occupied work centers	Not allowed	Yes	9.5.1.2.1
Technology-specific protection	Yes	Yes	9.6.5

NA: Not applicable.

N Table 9.4.1 Maximum Stored Energy

ESS Type	Maximum Stored Energy ^a (kWh)
Lead-acid batteries, all types	Unlimited
Nickel batteries ^b	Unlimited
Lithium-ion batteries, all types	600
Sodium nickel chloride batteries	600
Flow batteries ^c	600
Other battery technologies	200
Storage capacitors	20

^aFor ratings in amp-hrs, kWh should equal maximum rated voltage multiplied by amp-hr rating divided by 1000.

^bNickel battery technologies include nickel cadmium (Ni-Cad), nickel metal hydride (Ni-MH), and nickel zinc (Ni-Zn).

^cIncludes vanadium, zinc-bromine, polysulfide, bromide, and other flowing electrolyte-type technologies.

N 9.5.1.2 Non-Dedicated-Use Buildings.

N 9.5.1.2.1* Occupied Work Centers. ESS in occupied work centers shall comply with this section.

N 9.5.1.2.1.1 ESS shall be permitted in the same room as the equipment that they support.

N 9.5.1.2.1.2 ESS shall be housed in a noncombustible, locked cabinet or other enclosure to prevent access by unauthorized personnel unless located in an equipment room accessible only to authorized personnel.

N 9.5.1.2.2 Dwelling Units and Sleeping Units.

N 9.5.1.2.2.1 Stationary ESS shall not be installed in sleeping rooms or closets or spaces opening directly into sleeping rooms.

N 9.5.1.2.2.2 Stationary ESS shall not be installed in living areas of dwelling units unless specifically allowed in Chapters 9 through 13.

N 9.5.1.2.2.3 Portable ESS shall be permitted to be used in sleeping rooms and in habitable spaces of dwelling units provided they are listed and are used in accordance with the terms of their listing.

N 9.5.2 Outdoor Installations. Outdoor ESS installations shall comply with this section and as detailed in Table 9.5.2.

N 9.5.2.1 HMA. A HMA shall be required for lithium-ion ESS that exceed 600 kWh (2,160 MJ) for outdoor ESS installations,

ESS installations in open parking garages and on rooftops of buildings, and mobile ESS equipment.

N 9.5.2.2 Vegetation Control.

N 9.5.2.2.1 Areas within 10 ft (3 m) on each side of outdoor ESS shall be cleared of combustible vegetation and other combustible growth.

N 9.5.2.2.2 Single specimens of trees, shrubbery, or cultivated ground cover such as green grass, ivy, succulents, or similar plants used as ground covers shall be permitted to be exempt provided that they do not form a means of readily transmitting fire.

N 9.5.2.3 Walk-in Units.

N 9.5.2.3.1 Where an ESS includes an outer enclosure, the unit shall only be entered for inspection, maintenance, and repair of energy storage units and ancillary equipment and not be occupied for other purposes.

N 9.5.2.3.2* Walk-in units shall comply with this standard and local building code requirements.

N 9.5.2.3.3 Spacing shall not be required between the ESS and the enclosure walls in outdoor walk-in units.

N 9.5.2.4 Maximum Size.

N 9.5.2.4.1 Outdoor ESS walk-in units or ESS cabinets shall not exceed 53 ft × 8.5 ft × 9.5 ft (16.2 m × 2.6 m × 2.9 m), not including HVAC and other equipment.

N 9.5.2.4.2 Outdoor ESS walk-in units or ESS cabinets that exceed the dimensions in 9.5.2.4.1 shall be treated as indoor installations and comply with the requirements in 9.5.1.

N 9.5.2.5 Remote Locations. When agreeable with the ESS owner and approved by the AHJ, fire suppression systems and water supply shall not be required.

N 9.5.2.6 Locations Near Exposures.

N 9.5.2.6.1 Clearance to Exposures. ESS located outdoors shall be separated by a minimum 10 ft (3 m) from the following exposures:

- (1) Lot lines
- (2) Public ways
- (3) Buildings
- (4) Stored combustible materials
- (5) Hazardous materials
- (6) High-piled stock
- (7) Other exposure hazards not associated with electrical grid infrastructure

N 9.5.2.6.1.1 The required separation distances shall be permitted to be reduced to 3 ft (0.9 m) when a 1-hour freestanding fire barrier, suitable for exterior use, and extending 5 ft (1.5 m) above and 5 ft (1.5 m) beyond the physical boundary of the ESS installation is provided to protect the exposure.

N 9.5.2.6.1.2 Clearances to buildings shall be permitted to be reduced to 3 ft (0.9 m) where noncombustible exterior walls with no openings or combustible overhangs are provided on the wall adjacent to the ESS and the fire resistance rating of the exterior wall complies with the fire resistance requirements in 9.6.4.

N Table 9.5.2 Outdoor Stationary ESS Installations

Compliance Required	Locations		Reference
	Remote Locations	Near Exposures	
Administrative	Yes	Yes	Chapters 1–3
General	Yes	Yes	Sections 4.1–4.7
Maximum size	Yes	Yes	9.5.2.4
Clearance to exposures	NA	Yes	9.5.2.6.1
Means of egress separation	NA	Yes	9.5.2.6.1.7
Walk-in units	Yes	Yes	9.5.2.3
Vegetation control	Yes	Yes	9.5.2.2
Enclosures	Yes	Yes	4.6.12
Size and separation	No	Yes	9.4.2
Maximum stored energy	No	Yes	9.4.1
Smoke and fire detection	Yes	Yes	9.6.1
Fire control and suppression	Yes	Yes	9.6.2
Water supply	Yes	Yes	9.6.3
Signage	Yes	Yes	4.7.4
Occupied work centers	Not allowed	Not allowed	9.5.1.2.1
Technology-specific protection	Yes	Yes	9.6.5

NA: Not applicable.

N 9.5.2.6.1.3 Clearances to buildings shall be permitted to be reduced to 3 ft (0.9 m) based on fire and explosion testing complying with 9.1.5.

N 9.5.2.6.1.4 Where approved, clearances to exposures other than buildings shall be permitted to be reduced to 3 ft (0.9 m) where fire and explosion testing of the ESS in accordance with 9.1.5 demonstrates that a fire within the ESS enclosure will not generate radiant heat flux sufficient to ignite stored materials or otherwise threaten the exposure.

N 9.5.2.6.1.5 Clearances to buildings and exposures shall be permitted to be reduced to 3 ft (0.9 m) where the enclosure of the ESS has a 2-hour fire resistance rating established in accordance with ASTM E119 or UL 263.

N 9.5.2.6.1.6 ESS Exhaust Outlets. ESS exhaust outlets shall comply with the following:

- (1) Exhaust outlets from an ESS that exhaust other than ventilation air shall be located at least 15 ft (4.57 m) from heating, ventilating, and air conditioning (HVAC) air intakes, windows, doors, loading docks, ignition sources, and other openings into buildings and facilities.
- (2) Exhaust outlet(s) from an ESS shall not be directed onto means of egress, walkways, or pedestrian or vehicular travel paths.

N 9.5.2.6.1.7 Means of Egress Separation.

N (A) ESS located outdoors shall be separated from any accessible means of egress as required by the AHJ to ensure safe egress under fire conditions but in no case less than 10 ft (3 m).

N (B) Where approved by the AHJ, clearances to accessible means of egress shall be permitted to be reduced to 3 ft (0.9 m) where fire and explosion testing in accordance with 9.1.5 demonstrates that a fire within the ESS will not adversely impact the means of egress.

N 9.5.2.6.1.8 Exterior Wall Installations.

N (A) ESS shall be permitted to be installed outdoors on exterior walls of buildings when all of the following conditions are met:

- (1) The maximum stored energy of individual ESS units shall not exceed 20 kWh (72 MJ).
- (2) The ESS shall comply with applicable requirements in Chapter 4.
- (3) The ESS shall be installed in accordance with the manufacturer's instructions and their listing.
- (4) Individual ESS units shall be separated from each other by at least 3 ft (0.9 m).
- (5) The ESS shall be separated from doors, windows, operable openings into buildings, or HVAC inlets by at least 5 ft (1.5 m).

N (B) Where approved by the AHJ, smaller separation distances in 9.5.2.6.1.8(A)(4) and 9.5.2.6.1.8(A)(5) shall be permitted based on fire and explosion testing in accordance with 9.1.5.

N 9.5.3 Specific Outdoor Locations.

N 9.5.3.1 Rooftop and Open Parking Garage Installations. Rooftop and open parking garage ESS installations shall comply with this section and as detailed in Table 9.5.3.1.

N Table 9.5.3.1 Rooftop and Open Parking Garage ESS Installations

Compliance Required	Rooftops	Open Parking Garages	Reference
Administrative General	Yes	Yes	Chapters 1–3
Maximum size	Yes	Yes	Sections 4.1–4.7
Means of egress separation	Yes	Yes	9.5.2.4
Walk-in units	Yes	Yes	9.5.2.6.1.7
Enclosures	Yes	Yes	9.5.2.3
Clearance to exposures	Yes	Yes	4.6.12
Fire suppression and control	Yes	Yes	9.5.3.1.3
Size and separation	Yes	Yes	9.5.3.1.4
Maximum stored energy	Yes	Yes	9.4.2
Elevation	Yes	Yes	9.4.1
Smoke and fire detection	Yes	Yes	4.7.7
Signage	Yes	Yes	9.6.1
Occupied work centers	Not allowed	Not allowed	4.7.4
Open rack installations	Not allowed	Not allowed	9.5.1.2.1
Technology-specific protection	Yes	Yes	4.7.9
			9.6.5

NA: Not applicable.

N 9.5.3.1.1 Rooftop Installations.

N 9.5.3.1.1.1 Installations shall be permitted on rooftops of buildings that do not obstruct fire department rooftop operations when approved.

N 9.5.3.1.1.2 ESS and associated equipment that are located on rooftops and not enclosed by building construction shall comply with the following:

- (1) Stairway access to the roof for emergency response and fire department personnel shall be provided either through a bulkhead from the interior of the building or a stairway on the exterior of the building.
- (2) Service walkways at least 5 ft (1.5 m) in width shall be provided for service and emergency personnel from the point of access to the roof to the system.
- (3) ESS and associated equipment shall be located from the edge of the roof a distance equal to at least the height of the system, equipment, or component but not less than 5 ft (1.5 m).
- (4) The roofing materials under and within 5 ft (1.5 m) horizontally from an ESS or associated equipment shall be noncombustible or shall have a Class A rating when tested in accordance with ASTM E108 or UL 790.
- (5) A Class I standpipe outlet shall be installed at an approved location on the roof level of the building or in the stairway bulkhead at the top level.

- (6) Installations on rooftops over 75 ft (23 m) in height above grade shall be permitted when approved by the AHJ.
- (7) Access, service space, guards, and handrails shall be provided where required by the local building and mechanical codes.
- (8) A radiant energy-sensing fire detection system complying with Section 4.8 shall be provided to protect the ESS.
- (9) The ESS shall be a minimum of 10 ft (3 m) from the fire service access point on the rooftop.

N 9.5.3.1.2 Open Parking Garages. ESS and associated equipment that are located in open parking garages shall comply with all of the following:

- (1) ESS shall not be located within 50 ft (15.3 m) of air inlets for building HVAC systems. When approved, this distance is permitted to be reduced to 25 ft (7.6 m) if the automatic fire alarm system monitoring the radiant energy-sensing detectors de-energizes the ventilation system connected to the air intakes upon detection of fire.
- (2) ESS shall not be located within 25 ft (7.6 m) of exits leading from the attached building when located on a covered level of the parking structure not directly open to the sky above. When approved, the separation distance is permitted to be reduced to 10 ft (3 m) based on fire, explosion, and fault condition testing conducted in accordance with 9.1.5.
- (3) Means of egress separation shall comply with 9.5.2.6.1.7.
- (4) A radiant energy-sensing fire detection system complying with Section 4.8 shall be provided to protect the ESS.
- (5) An approved fence with a locked gate or other approved barrier shall be provided to keep the general public at least 5 ft (1.5 m) from the outer enclosure of the ESS.

N 9.5.3.1.3 Clearance to Exposures.

N 9.5.3.1.3.1 ESS located on rooftops and in open parking garages shall be separated by a minimum 10 ft (3 m) from the following exposures:

- (1) Buildings, except the portion of the building on which rooftop ESS is mounted
- (2) Lot lines
- (3) Public ways
- (4) Stored combustible materials
- (5) Locations where motor vehicles can be parked
- (6) Hazardous materials
- (7) Other exposure hazards

N 9.5.3.1.3.2 Clearances shall be permitted to be reduced to 3 ft (0.9 m) under the following conditions:

- (1) Where a 1-hour freestanding fire barrier, suitable for exterior use, and extending 5 ft (1.5 m) above and extending 5 ft (1.5 m) beyond the physical boundary of the ESS installation is provided to protect the exposure
- (2) Where the weatherproof ESS enclosure is constructed of noncombustible materials and it has been demonstrated that a fire within the enclosure will not ignite combustible materials outside the enclosure based on fire and explosion testing complying with 9.1.5

N 9.5.3.1.4 Fire Suppression and Control.

N 9.5.3.1.4.1 ESS located in walk-in enclosures on rooftops or in open parking garages shall be provided with automatic fire control and suppression systems within the ESS enclosure in accordance with Section 4.9.

N 9.5.3.1.4.2 Areas containing ESS other than walk-in units in open parking structures not open above to the sky shall be provided with an automatic fire suppression system complying with Section 4.9.

N 9.5.3.1.4.3 When approved by the AHJ, ESS shall be permitted to be installed in open parking garages without the protection of an automatic fire control and suppression system where fire and explosion testing conducted in accordance with 9.1.5 indicates that an ESS fire does not present an exposure hazard to parked vehicles or compromise the means of egress.

N 9.5.3.2 Mobile ESS Equipment and Operations. Mobile ESS operation shall be classified as specified in 9.5.3.2.1 or 9.5.3.2.2.

N 9.5.3.2.1 Charging and Storage.

N 9.5.3.2.1.1 For the purpose of 9.5.3.2, charging and storage shall cover the operation where mobile ESS are charged and stored so they are ready for deployment to another site and where they are charged and stored after a deployment.

N 9.5.3.2.1.2 Mobile ESS used to temporarily provide power to lead-acid and nickel-cadmium battery systems that are used for dc power for control of substations and control or safe shutdown of generating stations under the exclusive control of the electric utility and located outdoors or in building spaces used exclusively for such installations shall not be required to comply with 9.5.3.2.1.

N 9.5.3.2.2 Deployment.

N 9.5.3.2.2.1 For the purpose of 9.5.3.2, deployment shall cover operations where mobile ESS are located at a site other than the charging and storage site and are being used to provide power.

N 9.5.3.2.2.2 Mobile ESS used to temporarily provide power to lead-acid and nickel-cadmium battery systems that are used for dc power for control of substations and control or safe shutdown of generating stations under the exclusive control of the electric utility and located outdoors or in building spaces used exclusively for such installations shall not be required to comply with 9.5.3.2.2.

N 9.5.3.2.3 Approved Locations. Locations where mobile ESS are charged, stored, and deployed shall be restricted to the locations approved by the AHJ.

N 9.5.3.2.4 Local Staging. Mobile ESS in transit from the charging and storage location to the deployment location and back shall not be parked within 100 ft (30.5 m) of an occupied building for more than 1 hour during transit, unless specifically approved in advance by the AHJ.

N 9.5.3.2.5 Charging and Storage Requirements. Installations where mobile ESS are charged and stored shall be treated as permanent ESS installations and shall comply with the following sections, as applicable:

- (1) Indoor charging and storage shall comply with 9.5.2.4.1.
- (2) Outdoor charging and storage shall comply with 9.5.2.
- (3) Charging and storage on rooftops and in open parking garages shall comply with 9.5.3.1.

N 9.5.3.2.5.1 Construction documents complying with Section 4.2 shall be provided to the AHJ with any locally required construction permit applications for mobile ESS charging and storage locations.

N 9.5.3.2.5.2 Electrical connections shall be permitted to be made using temporary wiring complying with the manufacturer's instructions, the UL 9540 listing, and *NFPA 70*.

N 9.5.3.2.5.3 Fire suppression system connections to the water supply shall be acceptable to the AHJ.

N 9.5.3.2.6 Deployed Mobile ESS Requirements. Deployed mobile ESS equipment and operations shall comply with this section and Table 9.5.3.2.6.

N 9.5.3.2.6.1 Deployment Documents. The following information shall be provided to the AHJ with any locally required operational permit applications for mobile ESS deployments:

- (1) Relevant information for the mobile ESS equipment and protection measures in the construction documents required by Section 4.2
- (2) Location and layout diagram of the area in which the mobile ESS is to be deployed, including a scale diagram of all nearby exposures
- (3) Location and content of signage
- (4) Description of fencing to be provided around the ESS, including locking methods
- (5) Details on fire suppression, smoke and automatic fire detection, system monitoring, thermal management, exhaust ventilation, and explosion control, if provided
- (6) For deployment, the intended duration of operation, including anticipated connection and disconnection times and dates
- (7) Description of the temporary wiring, including connection methods, conductor type and size, and circuit over-current protection to be provided
- (8) Description of how fire suppression system connections to water supplies or extinguishing agents are to be provided

- (9) Contact information for personnel who are responsible for maintaining and servicing the equipment and responding to emergencies

N 9.5.3.2.6.2 Restricted Locations. Deployed mobile ESS operations shall not be located indoors, in covered parking garages, on rooftops, below grade, or under building overhangs.

N 9.5.3.2.6.3 Wheeled Vehicles. Mobile operations on wheeled vehicles or trailers shall not be required to comply with 4.7.2 seismic protection requirements.

N 9.5.3.2.6.4 Fire Suppression Connections. Fire suppression system connections to the water supply shall be permitted to use approved temporary connections.

N 9.5.3.2.6.5 Duration.

N (A) Mobile ESS deployments that provide power for durations longer than 30 days shall comply with 9.5.3.2.5.

N (B) Mobile ESS deployments in excess of 30 days, for emergencies, shall not be required to comply with 9.5.3.2.5, with AHJ approval.

N 9.5.3.2.6.6 Clearance to Exposures.

N (A) Deployed mobile ESS shall be separated by a minimum 10 ft (3 m) from the following exposures:

- (1) Public ways
- (2) Buildings
- (3) Stored combustible materials
- (4) Hazardous materials
- (5) High-piled stock
- (6) Other exposure hazards not associated with electrical grid infrastructure

N (B) Required separation distances shall be permitted to be reduced in accordance with 9.5.2.6.1.1 through 9.5.2.6.1.4.

N (C) Deployed mobile ESS shall be separated by a minimum 50 ft (15.3 m) from public seating areas and from tents, canopies, and membrane structures with an occupant load of 30 or more.

N 9.5.3.2.6.7 Electrical Connections. Electrical connections shall be made in accordance with the manufacturer's instructions.

N (A) Temporary wiring for electrical power connections shall comply with *NFPA 70* or equivalent code.

N (B) Fixed electrical wiring shall not be permitted.

N 9.5.3.2.6.8 Fencing.

N (A) An approved fence with a locked gate or other approved barrier shall be provided to keep the general public at least 5 ft (1024 mm) from the outer enclosure of a deployed mobile ESS.

N (B) A mobile ESS that is locked to prevent access by unauthorized persons shall be permitted to comply with 9.5.3.2.6.8(A).

N 9.6 Protection and Remediation.

N 9.6.1 Smoke and Fire Detection. Areas containing ESS systems located within buildings or structures shall be provided with a smoke detection or radiant energy-sensing system in accordance with Section 4.8, unless modified by this chapter.

N Table 9.5.3.2.6 Mobile Energy Storage Systems (ESS)

Compliance Required	Deployment	Reference
Administrative	Yes	Chapters 1–3
General	Yes	Sections 4.1–4.7
Size and separation	Yes ^a	9.4.2
Maximum stored energy	Yes	9.4.1
Fire and smoke detection	Yes ^b	9.6.1
Fire control and suppression	Yes ^c	9.6.2
Maximum size	Yes	9.5.2.4
Vegetation control	Yes	9.5.2.2
Means of egress separation	Yes	9.5.2.6.1.7
Technology-specific protection	Yes	9.6.5

^aIn walk-in units, spacing is not required between ESS units and the walls of the enclosure.

^bAlarm signals are not required to be transmitted to an approved location for mobile ESS deployed 30 days or less.

^cOnly required for walk-in units.

N 9.6.2 Fire Control and Suppression.

N 9.6.2.1 Fire control and suppression for rooms or areas within buildings and outdoor walk-in units containing ESS shall be provided in accordance with Section 4.9, unless modified by this chapter.

N 9.6.2.2 Lead-Acid and Nickel-Cadmium Battery Systems.

N 9.6.2.2.1 Lead-acid and nickel-cadmium battery systems less than 50 V ac, 60 V dc that are in telecommunications facilities for installations of communications equipment under the exclusive control of communications utilities and located outdoors or in building spaces used exclusively for such installations that comply with NFPA 76 shall not be required to have a fire suppression system installed.

N 9.6.2.2.2 Lead-acid battery systems in uninterruptible power supplies listed and labeled in accordance with the application used for standby power applications, which is limited to not more than 10 percent of the floor area on the floor on which the ESS is located, shall not be required to have a fire suppression system installed.

N 9.6.2.2.3* Lead-acid and nickel-cadmium battery systems that are used for dc power for control of substations and control or safe shutdown of generating stations under the exclusive control of the electric utility and located outdoors or in building spaces used exclusively for such installations shall not be required to have a fire suppression system installed.

N 9.6.2.3 Where more than one ESS technology is present within a fire area, the fire protection systems shall be designed to protect the greatest hazard.

N 9.6.3 Water Supply.

N 9.6.3.1 Sites where nonmechanical ESS are installed shall be provided with a permanent source of water for fire protection in accordance with 4.9.4, unless modified by this chapter.

N 9.6.3.2 Lead-Acid and Nickel-Cadmium Systems.

N 9.6.3.2.1* Normally unoccupied, remote standalone telecommunications structures with a gross floor area of less than 1500 ft² (139 m²) with lead-acid and nickel-cadmium battery systems less than 50 V ac, 60 V dc that are in telecommunications facilities for installations of communications equipment

under the exclusive control of communications utilities and located outdoors or in building spaces used exclusively for such installations that comply with NFPA 76 shall not be required to have a fire water supply.

N 9.6.3.2.2 Lead-acid and nickel-cadmium battery systems that are used for dc power for control of substations and control or safe shutdown of generating stations under the exclusive control of the electric utility and located outdoors or in building spaces used exclusively for such installations shall not be required to have a fire water supply.

N 9.6.4 Fire Barriers. Rooms or spaces containing ESS shall be separated from other areas of the building by fire barriers with a minimum 2-hour fire resistance rating and horizontal assemblies with a minimum 2-hour fire resistance rating, constructed in accordance with the local building code.

N 9.6.4.1 Rooms or spaces, containing only ESS listed to UL 9540 and that are marked as meeting the cell-level performance criteria of UL 9540A, shall be permitted to be separated from other areas of the building with a minimum 1-hour fire resistance rating constructed in accordance with local building codes.

N 9.6.4.2 Lead-acid and nickel cadmium battery systems that are used for dc power for control of substations and control or safe shutdown of generating stations under the exclusive control of the electric utility and located outdoors or in building spaces used exclusively for such installations shall not be required have a 2-hour fire resistance separation from the rest of the building.

9.6.5 Technology-Specific Requirements. Electrochemical ESS shall comply with the applicable sections of Chapters 4 and 9 as specified in Table 9.6.5.

N 9.6.5.1* Exhaust Ventilation During Normal Operation. Where required by Table 9.6.5 or elsewhere in this standard, exhaust ventilation during normal operation shall be provided for rooms, enclosures, walk-in units, and cabinets as follows:

- (1) ESS rooms and walk-in units shall use mechanical exhaust ventilation in accordance with 9.6.5.1.5.
- (2) Outdoor ESS cabinets shall use either mechanical or natural exhaust ventilation in accordance with 9.6.5.1.4 or 9.6.5.1.5.

Table 9.6.5 Electrochemical ESS Technology-Specific Requirements

Compliance Required	Battery Technology				Flow	Sodium Nickel Chloride	EDLC Energy Storage	Other Electrochemical ESS and Battery Technologies*	Reference
	Lead-Acid	Ni-Cd, Ni-MH, Ni-Zn	Lithium-Ion						
Exhaust ventilation	Yes	Yes	No		Yes	No	Yes	Yes	9.6.5.1
Spill control	Yes †	Yes †	No		Yes	No	Yes	Yes	9.6.5.2
Neutralization	Yes †	Yes †	No		Yes	No	Yes	Yes	9.6.5.3
Safety caps	Yes	Yes	No		No	No	Yes	Yes	9.6.5.4
Thermal runaway	Yes	Yes	Yes		No	Yes	Yes	Yes	9.6.5.5
Explosion control	Yes	Yes	Yes		No	Yes	Yes	Yes	9.6.5.6

*The protection in this column is not required if documentation acceptable to the AHJ, including a hazard mitigation analysis complying with Section 4.4, provides justification that the protection is not necessary based on the technology used.

†Applicable only to vented (e.g., flooded) batteries.

- N 9.6.5.1.1 Ni-MH Batteries.** Exhaust ventilation shall not be required for Ni-MH batteries.
- N 9.6.5.1.2 Abnormal Conditions.** Protection against the release of flammable gases during abnormal charging or thermal runaway conditions shall be in accordance with 9.6.5.6.
- N 9.6.5.1.3 Indoor ESS Cabinets.** Exhaust ventilation for ESS cabinets installed indoors shall evaluate air movement through the cabinet and exhaust from the room.
- N 9.6.5.1.4* Natural Exhaust Ventilation.** Exhaust ventilation shall be designed to limit the maximum concentration of flammable gas to 25 percent of the lower flammable limit (LFL) of the total volume of the outdoor cabinet during the worst-case event of simultaneous "boost" charging of all the batteries, in accordance with nationally recognized standards.
- N 9.6.5.1.5 Mechanical Exhaust Ventilation.** Exhaust ventilation shall be provided in accordance with the applicable mechanical code and one of the following:
- (1) Where hydrogen is the gas generated, an exhaust ventilation rate based on hydrogen generation estimates sufficient to limit the maximum concentration of hydrogen to 1.0 percent of the total volume of the room, walk-in unit, or cabinet during the worst-case event of simultaneous "boost" charging of all the batteries, in accordance with nationally recognized standards
 - (2) An exhaust ventilation rate based on the area of not less than 1 ft³/min/ft² (5.1 L/sec/m²) of floor area of the room, walk-in unit, enclosure, container, or cabinet
- N 9.6.5.1.5.1 Mechanical exhaust ventilation** shall be either continuous or activated by a gas detection system in accordance with 9.6.5.1.5.4.
- N 9.6.5.1.5.2 Required mechanical exhaust ventilation systems** shall be installed in accordance with the manufacturer's installation instructions and local building, mechanical, and fire codes.
- N 9.6.5.1.5.3 Required mechanical exhaust ventilation systems** shall either be supervised by an approved central, proprietary, or remote station service in accordance with *NFPA 72* or initiate an audible and visual signal at an approved, constantly attended location.
- N 9.6.5.1.5.4*** Where gas detection is used to activate exhaust ventilation in accordance with 9.6.5.1.5.1, rooms, walk-in units, enclosures, walk-in containers, and cabinets containing ESS shall be protected by an approved continuous gas detection system that complies with the following:
- (1) The gas detection system shall be designed to activate the mechanical exhaust ventilation system when the level of flammable gas detected in the room, walk-in unit, enclosure, container, and cabinet exceeds 25 percent of the LFL of the flammable gas mixture.
 - (2) The mechanical exhaust ventilation system shall remain on until the flammable gas detected is less than 25 percent of the LFL of the flammable gas mixture.
 - (3) The gas detection system shall be provided with a minimum of 2 hours of standby power.
 - (4) Failure of the gas detection system shall annunciate a trouble signal at an approved central, proprietary, or remote station in accordance with *NFPA 72* or at an approved, constantly attended location.
- N 9.6.5.2 Spill Control.**
- N 9.6.5.2.1** Rooms, buildings, or areas containing ESS with free-flowing liquid electrolyte in individual vessels having a capacity of more than 55 gal (208 L) or multiple vessels having an aggregate capacity exceeding 1000 gal (3785 L) shall be provided with spill control to prevent the flow of liquids to adjoining areas.
- N 9.6.5.2.2*** An approved method and materials for the control of a spill of electrolyte or other hazardous liquid shall be provided that will be capable of controlling a spill from the single largest vessel.
- N 9.6.5.2.3** In rooms, buildings, or areas protected by water-based fire protection systems, the capacity of the spill containment system shall accommodate the capacity of the expected fire protection system discharge for a period of 10 minutes.
- N 9.6.5.2.4** The capacity increase in 9.6.5.2.3 shall not apply to integral spill containment systems that are shielded from the fire protection system discharge.
- N 9.6.5.2.5** Sealed valve-regulated lead-acid (VRLA) batteries and other ESS equipment with immobilized electrolyte and immobilized hazardous liquids shall not require spill control.
- N 9.6.5.2.6** Rooms, buildings, or areas containing other hazardous materials shall include spill control as required in *NFPA 1*.
- N 9.6.5.3 Neutralization.**
- N 9.6.5.3.1*** An approved method to neutralize spills from ESS with free-flowing electrolyte shall be provided.
- N 9.6.5.3.2** Neutralization shall not be required for ESS with immobilized electrolyte.
- N 9.6.5.3.3** The method shall be capable of neutralizing a spill from the largest battery or vessel to a pH between 5.0 and 9.0.
- 9.6.5.4* Safety Caps.** Where required by Table 9.6.5, vented batteries used in ESS shall be provided with flame-arresting safety caps.
- 9.6.5.5* Thermal Runaway Protection.** Where required by Table 9.6.5, a listed device evaluated as part of the ESS or other approved method shall be provided to manage charging and discharging during normal operation of the ESS to maintain batteries and capacitors within their safe operating parameters and preclude thermal runaway.
- N 9.6.5.5.1** Thermal runaway protection shall not be required for vented (e.g., flooded) lead-acid and Ni-Cd batteries.
- N 9.6.5.5.2** Thermal runaway protection shall be permitted to be provided by the battery management system or a capacitor ESS management system that has been evaluated as part of the UL 1973 or UL 9540 listing.
- N 9.6.5.6* Explosion Control.**
- N 9.6.5.6.1** Where required elsewhere in this standard, explosion prevention or deflagration venting shall be provided in accordance with this section.
- N 9.6.5.6.1.1** Explosion prevention and deflagration venting shall not be required where approved by the AHJ based on fire and explosion testing in accordance with 9.1.5 and a deflagration hazard study demonstrating that flammable gas concentrations cannot exceed 25 percent of the LFL.

N 9.6.5.6.1.2 Explosion control shall not be required for the following:

- (1) Lead-acid and Ni-Cd battery systems less than 50 V ac, 60 V dc in telecommunications facilities for installations of communications equipment under the exclusive control of communications utilities located in building spaces or walk-in units used exclusively for such installations that comply with NFPA 76
- (2) Lead-acid and Ni-Cd battery systems that are and used for dc power for control of substations and control or safe shutdown of generating stations under the exclusive control of the electric utility located outdoors or in building spaces used exclusively for such installations
- (3) Lead-acid battery systems in uninterruptible power supplies listed and labeled in accordance with the application used for standby power applications, and housed in a single cabinet in a single fire area in buildings or walk-in units
- (4) Lead-acid and Ni-Cd batteries listed in accordance with UL 1973
- (5) Batteries listed in accordance with UL 1973 that do not go into thermal runaway or produce flammable gas in the UL 9540A cell level test or equivalent test

N 9.6.5.6.2 Protection against the release of flammable gases during normal operation shall be in accordance with 9.6.5.1.

N 9.6.5.6.3* ESS installed within a room, building, ESS cabinet, ESS walk-in unit, or otherwise nonoccupiable enclosure shall be provided with one of the following:

- (1) Explosion prevention systems designed, installed, operated, maintained, and tested in accordance with NFPA 69
- (2) Deflagration venting installed and maintained in accordance with NFPA 68

N 9.6.5.6.4* Where approved, ESS cabinets designed to ensure that no hazardous pressure waves, debris, shrapnel, or enclosure pieces are ejected, as validated by installation level fire and explosion testing and an engineering evaluation complying with 9.1.5 that includes the cabinet, shall be permitted in lieu of providing explosion control that complies with NFPA 68 or NFPA 69.

N 9.6.5.6.5 ESS enclosures and cabinets shall be designed so explosive discharge of gases or projectiles are not ejected during fire and explosion testing complying with 9.1.5 that includes the ESS enclosure and cabinets.

N 9.6.5.6.6* Where ESS batteries or cabinets are installed in a container outdoors, other than a walk-in unit, the installation shall comply with one of the following:

- (1) The container shall be provided with explosion control complying with 9.6.5.6.3.
- (2) Combination of the container and cabinets shall be tested together to show compliance with 9.6.5.6.1.1.

N 9.6.5.6.7 Where gas detection is used to activate a combustible gas concentration reduction system and based on an appropriate NFPA 69 deflagration study, enclosures containing ESS shall be protected by an approved continuous gas detection system that complies with the following:

- (1) The gas detection system shall be designed to activate the combustible gas concentration reduction system on detection of flammable gases at no more than 10 percent

of the LFL of the gas mixture or of the individual components.

- (2) The combustible gas concentration reduction system shall remain on to ensure the flammable gas does not exceed 25 percent of the LFL of the gas mixture or of the individual components.
- (3) The gas detection system and combustible gas concentration reduction system shall be provided with a minimum of 2 hours of standby power.
- (4) For lithium-ion batteries, the gas detection system shall be provided with a minimum of 24 hours of standby power and 2 hours in alarm or as required by the HMA.
- (5) The gas detection system shall annunciate the following at an approved central, proprietary, or remote station in accordance with NFPA 72, or at an approved constantly attended location:
 - (a) A trouble signal upon failure of the gas detection system
 - (b) An alarm signal if flammable gas concentration exceeds 10 percent of the LFL

N 9.6.5.6.8 Compartmentalization created by cold and hot aisle arrangements within the ESS enclosure shall be addressed in accordance with the following:

- (1) For NFPA 69 designs, the performance of ventilation systems shall be independently verified for a thermal runaway event in either aisle/subcompartment.
- (2) For NFPA 68 designs, the placement of explosion relief panels shall ensure that the explosion hazard is addressed for both hot and cold aisles/subcompartments.
- (3) The gas detection system shall be designed to activate on detection of flammable gas in either aisle/subcompartment.

N 9.6.5.6.9 The protection design shall demonstrate that deflagrations are not propagated to interconnected or adjacent cabinets, enclosures, or rooms.

N 9.6.6 Remediation Measures.

N 9.6.6.1* Authorized Service Personnel. Where a fire or other event has damaged the ESS and ignition or reignition of the ESS is possible, the owner, agent, or lessee shall dispatch authorized service personnel to assist emergency first responders to mitigate the hazard or remove damaged equipment from the premises with a response time approved by the AHJ.

N 9.6.6.2* Hazard Support Personnel. Where required by the AHJ for public safety, the owner or their authorized agent shall provide hazard support personnel at the owner's expense.

N 9.6.6.2.1* Trained hazard support personnel shall be approved by the AHJ.

N 9.6.6.2.2 Trained hazard support personnel shall be available to respond to possible ignition or re-ignition of the damaged ESS, within the response time noted in the approved emergency operations plan.

N 9.6.6.2.3 The authorized service personnel shall be permitted to perform the duties of the hazard support personnel.

N 9.6.6.2.4* Required hazard support personnel shall monitor the ESS continuously in a method approved by the AHJ from the time the fire department releases the emergency scene until the hazard is mitigated and the AHJ gives authorization to

the owner or their authorized agent that onsite hazard support personnel are no longer required.

N 9.6.6.2.5* On-duty hazard support personnel shall have the following responsibilities:

- (1) Ensure the security and safety of the ESS site in accordance with the emergency operation plan and decommissioning plan
- (2) Keep diligent watch for fires or signs of off-gassing, obstructions to means of egress, and other hazards for the time required in accordance with 9.6.6.2.4
- (3) Ensure a means of communication is available to immediately contact the fire department if their assistance is needed to mitigate any hazards
- (4) Take prompt measures for remediation of hazards
- (5) Take prompt measures to assist in the evacuation of the public from the structures in accordance with the emergency operations plan
- (6) Allow only authorized personnel to enter the ESS site
- (7) Ensure authorized personnel are wearing proper PPE
- (8) Where required by the AHJ, maintain a written or electronic log of all personnel entering/leaving the portion of the site containing the ESS
- (9) Record all postincident tasks performed

Chapter 10 (Reserved)

Chapter 11 Fuel Cell Energy Storage Systems

11.1 Installation and Maintenance.

N 11.1.1 Stationary fuel cell ESS shall comply with the following requirements of Chapter 4:

- (1) Charge controllers (*see 4.6.8*)
- (2) Inverters and converters (*see 4.6.9*)
- (3) Energy storage management system (ESMS) (*see 4.6.10*)
- (4) Impact protection (*see 4.7.5*)
- (5) Smoke and fire detection (*see Section 4.8*)
- (6) Fire control and suppression (*see Section 4.9*)
- (7) Water supply (*see 4.9.4*)
- (8) Signage (*see 4.7.4*)
- (9) Combustible storage (*see Section 4.5*)
- (10) Hazard mitigation analysis (*see Section 4.4*)
- (11) Emergency planning and training (*see Section 4.3*)
- (12) Construction documents (*see Section 4.2*)

11.1.2 Non-hydrogen-fueled stationary fuel cell ESS shall be installed and maintained in accordance with *NFPA 70*, *NFPA 853*, the manufacturer's instructions, and the equipment listing.

11.1.3 Hydrogen-fueled stationary fuel cell ESS shall be installed and maintained in accordance with *NFPA 2*, *NFPA 70*, *NFPA 853*, the manufacturer's instructions, and the equipment listing.

11.2 Fuel-Cell-Powered Vehicle Use.

11.2.1 The temporary use of the dwelling unit owner's or occupant's fuel-cell-powered vehicle to power the dwelling in a one- and two-family dwelling or townhouse unit while parked in an attached or detached garage or outside shall only be required to comply with the vehicle manufacturer's instructions and *NFPA 70*.

11.2.2 The temporary use of the dwelling unit owner's or occupant's fuel-cell-powered vehicle to power the dwelling in a one- and two-family dwelling or townhouse unit while parked in an attached or detached garage or outside shall not be for more than 30 days.

Chapter 12 Superconducting Magnet Energy Storage (Reserved)

Chapter 13 Flywheel Energy Storage Systems (FESS)

N 13.1 Application.

N 13.1.1 The requirements of this chapter shall apply to the installation of flywheel ESS (FESS).

N 13.1.2* This chapter shall not apply to FESS for electric utilities under the exclusive control of the electric utility and located outdoors or in building spaces used exclusively for such installations.

N 13.1.3* FESS shall not be installed in individual one- or two-family dwellings or in townhouse units.

N 13.2 Protection Features. FESS installations shall comply with the requirements of Chapters 4 through 8, except as specified in Table 13.2.

N 13.2.1 The construction documents required by 4.2.1.1 shall apply to FESS except for 4.2.1.1(2) and 4.2.1.1(7).

N 13.2.2 The requirements in 4.3.2.1.4 for the emergency operations plan shall apply except for 4.3.2.1.4(5) and 4.3.2.1.4(6).

N 13.2.3 A hazard mitigation analysis shall only be required for FESS in accordance with 4.4.1(2).

N 13.2.4 FESS shall be listed in accordance with UL 9540.

N 13.2.5* FESS shall not be installed in locations that could stress the bearing systems and impact their operation.

N 13.2.6* The energy storage management system (ESMS) of a FESS shall include bearing monitoring for magnetic bearings.

N 13.2.6.1 There shall be some means (e.g., alarm, hazard light, warning signal to control panel) to annunciate when bearing changes are due.

N 13.2.6.2* The ESMS shall monitor and record temperature and vibration of the FESS.

N 13.2.7 FESS installed on elevated parking garages or roof tops, or in high-rise buildings shall meet the seismic requirements for that installation.

N 13.2.7.1 The seismic ratings of the FESS and suitability of mounting means shall be verified during installation.

N 13.2.7.2 The engineering analysis for a FESS installation in an elevated location shall address stresses on floor loading due to wind forces.

N 13.2.8* An enclosure means to contain moving parts of the FESS shall be provided.

N 13.2.9* The rotor of mobile FESS shall be completely stopped (i.e., contain no energy) prior to transportation.

N Table 13.2 FESS Technology-Specific Requirements

Compliance Required	Applicable Chapter Reference	Chapter 13 Modifications
Construction documents	4.2	4.2.1.1 applies except as modified in 13.2.1 and 13.2.2 4.2.1.2—N/A 4.2.1.3—N/A 4.2.1.4—N/A
Emergency planning and training	4.3	4.3.2.1.4 applies except as noted in 13.2.2 4.3.2.1.5—N/A (<i>see 13.1.2</i>)
Hazard mitigation analysis (HMA)	4.4	4.4.1 applies except as noted in 13.2.3
Fire and explosion testing	9.1.5	N/A
Equipment	Section 4.6	See also 13.2.4 and 13.1.2
Retrofits	4.6.3	4.6.3.2—N/A 4.6.3.3—N/A (<i>see 13.1.2</i>)
Environment	4.6.7	See also 13.2.5
Charge controllers	4.6.8	N/A
Energy storage management systems	4.6.10	See also 13.2.6 and 13.2.6.1
Reused equipment	4.6.5	N/A
Seismic protection	4.7.2	See also 13.2.7 and 13.2.7.1
Fire barriers	9.6.4	N/A
Elevation	4.7.7	N/A (<i>see 13.2.7.2</i>)
Open rack installation	4.7.9	N/A
ESS dedicated-use buildings	9.3.1.1	N/A
Non-dedicated-use buildings	9.3.1.2	N/A
Outdoor installations	9.3.2	N/A
Enclosures	4.6.12	See also 13.2.8
Rooftop and open parking garage installations	9.5.3.1	N/A except as noted in 13.2.7, 13.2.7.1, and 13.2.7.2
Mobile ESS equipment and operations	9.5.3.2	9.5.3.2.1.2—N/A 9.5.3.2 applies (<i>see 13.2.9</i>) 9.5.3.2.2.2—N/A 9.5.3.2.5.3—N/A 9.5.3.2.6—N/A; requirements for deployed mobile FESS in accordance with Chapter 13
Size and separation	9.4.2	N/A
Maximum stored energy	9.4.1	N/A
Exhaust ventilation	9.6.5.1	N/A
Smoke and fire detection	Section 4.8	N/A (<i>see 13.2.10</i>)
Fire control and suppression	Section 4.9	N/A (<i>see 13.2.11</i>)
Explosion control	9.6.5.6	N/A (<i>see 13.2.8</i>)
Water supply	4.9.4	N/A
System interconnection	Chapter 5	Section 5.3—N/A
Commissioning	Chapter 6	See also Section 13.3
Operation and maintenance	Chapter 7	See also Section 13.4 7.1.3—N/A
Decommissioning	Chapter 8	See also Section 13.5

N/A: Not applicable.

N 13.2.10 Smoke and fire detection for FESS installations shall be in accordance with the local building code.

N 13.2.11 Fire control and suppression for FESS installation shall be in accordance with the local building code.

N 13.2.12* Separation or barriers shall be used to ensure that catastrophic failure of a flywheel does not propagate to other flywheels or energy storage systems in the area.

N 13.3* **Commissioning.** Prior to commissioning, correct installation for mechanical securement and containment shall be confirmed.

N 13.4* **Operation and Maintenance.** As part of routine maintenance there shall be procedures for monitoring/checking for bearing wear.

N 13.4.1 During installation, the AHJ shall confirm that the maintenance procedures have both a process for determining the bearing change interval and follow-up procedures.

N 13.4.2* The AHJ shall confirm that the maintenance procedures include a check of the status of the vacuum on a periodic basis.

N 13.4.3 Spin Down.

N 13.4.3.1 The maximum time to spin down shall be included in the maintenance documentation to ensure that the rotor has coasted down to zero prior to maintenance or moving the FESS.

N 13.4.3.2 The technician shall make certain that they have confirmed the maximum spin down time for safety reasons.

N 13.5 Decommissioning.

N 13.5.1* For decommissioning, all the energy shall be completely dissipated from the FESS prior to FESS removal.

N 13.5.2 Rotor braking shall be required unless enough time is provided in the decommissioning procedures to allow it to spin down.

Chapter 14 Storage of Lithium Metal or Lithium-ion Batteries

14.1 Batteries. Areas associated with the collection or storage of lithium metal or lithium-ion batteries shall comply with this chapter.

14.1.1 The following areas shall be exempt from the requirements of this chapter:

- (1) Areas within a facility that are operated in accordance with procedures that provide for the state of charge of the lithium metal or lithium-ion batteries to be 30 percent or less
- (2) Areas where fire and fault condition testing conducted or witnessed and reported by an approved testing laboratory is provided showing that a fire involving the batteries in storage will be limited to the design area of an automatic sprinkler system installed in accordance with NFPA 13 and will not adversely impact occupant egress from the building or adversely impact adjacent stored materials or the building structure
- (3) Areas where new or refurbished batteries are installed for use in the devices, equipment, or vehicles they are designed to power
- (4) Areas where new or refurbished batteries are packed for use with the devices, equipment, or vehicles they are designed to power
- (5) Areas where new or refurbished batteries rated at no more than 300 Watt-hours (1.08 MJ) and lithium metal batteries containing no more than 25 g of lithium metal are in their original retail packaging
- (6) Areas where batteries are staged in the manufacturing area or along assembly lines during the manufacturing process

14.1.2 The procedures and test report specified in 14.1.1 shall be provided to the AHJ for review and approval.

14.2 Collection Locations. All areas located indoors in any occupancy where used lithium metal or lithium-ion batteries are collected from employees or the public shall comply with 14.2.1 through 14.2.3.

14.2.1* Individual containers shall not exceed 7.5 ft³ (0.21 m³) in size each, with an aggregate limit of 15 ft³ (0.42 m³).

14.2.2 Containers shall comply with all of the following:

- (1) Have a minimum of 3 ft (0.9 m) of open space from other battery collection containers and combustible materials
- (2) Be located a minimum of 5 ft (1.5 m) from exits from the room, space, or building
- (3) Be open-top and noncombustible or approved for battery collection use

14.2.3 Where combustible materials are located within the space between collection containers, the containers shall be spaced a minimum 10 ft (3 m) apart.

14.3 Indoor Storage Locations.**14.3.1 General.**

14.3.1.1 Batteries stored indoors shall be stored in accordance with one or more of the methods provided for in 14.3.2.1 through 14.3.2.4.

14.3.1.2 Battery terminals shall be protected either through battery design methods or a protective packaging method to prevent short-circuit of the battery.

14.3.2 Storage Methods.

14.3.2.1 Rooms or Spaces. Batteries shall be permitted to be stored in rooms or spaces complying with 14.3.2.1.1 and 14.3.2.1.3.

14.3.2.1.1 The rooms or spaces shall be separated from the remainder of the building areas by fire barriers with a 2-hour fire resistance rating and with horizontal assemblies with a 2-hour fire resistance rating constructed in accordance with the local building code.

14.3.2.1.2 The rooms or spaces shall be provided with a fire alarm system activated by an air-aspirating smoke detector system or a radiant-energy detection system with occupant notification installed in accordance with NFPA 72.

14.3.2.1.3 The rooms or spaces shall be provided with an automatic sprinkler system designed and installed in accordance with NFPA 13.

14.3.2.2 Prefabricated Portable Structure. Batteries shall be permitted to be stored in prefabricated portable buildings or containers complying with 14.3.2.2.1 and 14.3.2.2.3.

14.3.2.2.1 The prefabricated portable buildings or containers shall be listed or approved with a 2-hour fire resistance rating.

14.3.2.2.2 The prefabricated portable buildings or containers shall be provided with a fire alarm system activated by an air-aspirating smoke detector system or a radiant-energy detection system with occupant notification installed in accordance with NFPA 72.

14.3.2.2.3 The prefabricated portable buildings or containers shall be provided with an approved automatic fire sprinkler system installed in accordance with NFPA 13.

14.3.2.3 Metal Drums. Batteries shall be permitted to be stored in metal drums with batteries separated from each other by vermiculite or other approved material or in containers approved for battery collection and storage activities complying with 14.3.2.3.1 and 14.3.2.3.3.

△ 14.3.2.3.1 Each area containing such metal drums or approved containers shall be both of the following:

- (1) Not exceeding 900 ft² (61 m²) in area
- (2) Separated from other battery storage areas by a minimum of 10 ft (3 m)

14.3.2.3.2 Each area containing metal drums or approved containers with batteries shall be provided with a fire alarm system activated by an air-aspirating smoke detector system or a radiant-energy detection system with occupant notification installed in accordance with NFPA 72.

N 14.3.2.3.3 Each area containing metal drums or approved containers with batteries shall be provided with an approved automatic fire sprinkler system installed in accordance with NFPA 13.

14.3.2.4 Containers Approved for Transportation. Batteries shall be permitted to be stored in containers approved for use in transportation that will prevent an event from propagating beyond the container complying with 14.3.2.4.1 and 14.3.2.4.3.

△ 14.3.2.4.1 Each area containing the approved transportation containers shall be both of the following:

- (1) Not exceeding 900 ft² (61 m²) in area
- (2) Separated from other battery storage areas by a minimum of 10 ft (3 m)

14.3.2.4.2 Each area containing the approved transportation containers shall be provided with a fire alarm system activated by an air-aspirating smoke detector system or a radiant-energy detection system with occupant notification installed in accordance with NFPA 72.

N 14.3.2.4.3 Each area containing the approved transportation containers shall be provided with an approved automatic fire sprinkler system installed in accordance with NFPA 13.

14.4 Prevention and Mitigation. A plan that provides for the prevention of fire incidents and includes early detection mitigation measures shall be provided to the AHJ for review and approval.

N 14.5 Explosion Protection.

N 14.5.1 Deflagration Potential.

N 14.5.1.1 The potential for a deflagration involving the off-gassing of flammable gases during a thermal runaway shall be analyzed.

N 14.5.1.2 Explosion protection shall be installed if the potential for a deflagration involving the off-gassing of flammable gases during a thermal runaway exists.

N 14.5.2 A written hazard analysis prepared by a registered design professional with expertise in fire protection engineering shall be submitted to the AHJ for review and approval.

14.6 Outdoor Storage Location.

14.6.1 Outdoor storage locations for lithium metal or lithium-ion batteries shall comply with the following:

- (1) Individual pile sizes shall be limited to 900 ft² (83.6 m²) in area separated from other piles by 10 ft (3 m).
- (2) Piles located outdoors shall be separated by a minimum 20 ft (6.1 m) from the following exposures:
 - (a) Lot lines
 - (b) Public ways

- (c) Buildings
- (d) Other storage
- (e) Hazardous materials
- (f) Other exposure hazards

14.6.2 Clearances shall be permitted to be reduced to 3 ft (0.9 m) where a 3-hour freestanding fire barrier, suitable for exterior use, and extending 5 ft (1.5 m) above and extending 5 ft (1.5 m) beyond the physical boundary of the pile is provided to protect the exposure.

N 14.6.3 Weather Protection. Where weather protection is provided for sheltering outdoor battery storage areas, such areas shall be considered outdoor storage areas if all of the following conditions are met:

- (1) Supports and walls shall not obstruct more than one side or more than 25 percent of the perimeter of the storage area.
- (2) The distance from the structure and the structural supports to buildings, lot lines, public ways, or means of egress to a public way shall be not less than the distance required by 14.6.1 for outdoor storage of batteries without weather protection.
- (3) The structure shall be of approved noncombustible construction and not exceed 3,600 ft² (334.5 m²) in area.

N 14.6.4 Outdoor storage areas with an aggregate area greater than 400 ft² (37.1 m²) shall be provided with a fire alarm system activated by a radiant-energy detection system with occupant notification installed in accordance with NFPA 72.

Chapter 15 One- and Two-Family Dwellings and Townhouse Units

15.1* General. ESS installations with a rating of 1 kWh (3.6 MJ) or greater and associated with one- or two-family dwellings or townhouse units shall comply with the requirements of this chapter.

15.2 Equipment Listings.

△ 15.2.1 ESS shall be listed and labeled in accordance with UL 9540.

15.3 Installation. ESS shall be installed in accordance with the manufacturer's instructions and their listing.

15.3.1 ESS Spacing. Individual ESS units shall be separated from each other by a minimum of 3 ft (914 mm) unless smaller separation distances are documented to be adequate based on fire and explosion testing complying with 9.1.5.

N 15.3.2 Labeling. A label containing emergency contact information for the qualified service and maintenance providers shall be provided on the exterior of the installed ESS.

15.4 Locations.

15.4.1 ESS shall only be installed in the following locations:

- (1) In attached garages separated from the dwelling unit living area and sleeping units in accordance with the local building code
- (2) In detached garages and detached accessory structures
- (3) Outdoors on exterior walls or on the ground located a minimum of 3 ft (914 mm) from doors and windows directly entering the dwelling unit

(4) In enclosed utility closets and storage or utility spaces where approved by the AHJ.

15.4.2 If the room or space where the ESS is to be installed is not finished or noncombustible, the walls and ceilings of the room or space shall be protected with not less than ½ in. Type X gypsum board.

15.4.3 ESS shall not be installed in sleeping rooms, or in closets or spaces opening directly into sleeping rooms.

Δ 15.5 Energy Ratings.

N 15.5.1 Individual ESS units shall have a maximum stored energy of 20 kWh.

15.5.2 The aggregate rating of the ESS shall not exceed the following for each location listed:

- (1) 40 kWh within utility closets, basements, and storage or utility spaces
- (2) 80 kWh in attached or detached garages and detached accessory structures
- (3) 80 kWh where outdoor wall mounted
- (4) 80 kWh where outdoor ground mounted

15.5.3 ESS installations exceeding the individual or aggregate ratings allowed by 15.5.1 or 15.5.2 shall comply with Chapters 4 through 9.

15.5.4* The use of an electric-powered vehicle to power the dwelling while parked shall comply with Section 15.11.

15.6 Electrical Installation. ESS shall be installed in accordance with *NFPA 70*.

15.6.1 Inverters shall be listed and labeled in accordance with UL 1741 or provided as part of the UL 9540 listing.

15.6.2* Systems connected to the utility grid shall use inverters listed for utility interaction.

15.7 Fire Detection.

15.7.1 Rooms and areas within dwelling units, basements, and attached garages in which ESS are installed shall be protected by interconnected smoke alarms in accordance with the local building code.

15.7.2 A heat detector or alarm, listed and interconnected to the smoke alarms, shall be installed in locations within dwelling units and attached garages where smoke alarms cannot be installed in accordance with their listing.

15.8 Protection from Impact. ESS installed in a location subject to vehicle damage shall be protected by approved barriers.

Δ 15.9 Exhaust Ventilation. Indoor installations of ESS that include batteries that produce hydrogen or other flammable gases during charging shall meet the exhaust ventilation requirements in accordance with 9.6.5.1.

15.10 ESS Toxic and Highly Toxic Gas Release During Normal Use. ESS that have the potential to release toxic or highly toxic gas during charging, discharging, and normal use conditions shall be installed outdoors.

15.11 Electric Vehicle Use.

15.11.1 The temporary use of the dwelling unit owner's or occupant's electric-powered vehicle to power the dwelling

while parked in an attached or detached garage or outside shall comply with the vehicle manufacturer's instructions and *NFPA 70*.

15.11.2 Temporary emergency use of the dwelling unit owner's or occupant's electric-powered vehicle to power the dwelling while parked in an attached or detached garage or outside shall be permitted.

Annex A Explanatory Material

Annex A is not a part of the requirements of this NFPA document but is included for informational purposes only. This annex contains explanatory material, numbered to correspond with the applicable text paragraphs.

N A.1.1 Energy generation equipment—even if it is tied to the ESS—is not covered under the scope. An example of this is a solar energy farm that feeds ESS on the same property. The solar generation and collection equipment are not governed by this standard. *NFPA 850* or other relevant standard should be applied for the design, construction, installation, commissioning, operation, and maintenance of generation facilities.

A.1.3 It is not the intent of *NFPA 855* to regulate equipment with integral standby power systems below the amounts in Table 1.3, such as emergency lighting units, fire alarm control units, computers, tablets, and other appliances and equipment.

Flywheel ESS have a lower energy threshold quantity because the stored energy can be released much more quickly in the case of a catastrophic failure. They are normally utilized for short-term and high-power applications. Although flywheel ESS do not represent the potential for fire hazards in the same manner as electrochemical systems, their total energy and size should be limited because of concerns with hazardous moving parts and structural concerns associated with containing those parts.

NA.1.3.1 Where approved by the AHJ, alternate safety requirements can be applied for purpose of research, development, or testing.

A.1.4.2 In order to help determine if an existing ESS installation presents an unacceptable risk and that retroactivity should apply, the AHJ can request a hazard mitigation analysis be submitted by the owner in accordance with Section 4.4.

Based on the hazardous mitigation analysis, the AHJ can apply retroactively any portions of this standard deemed appropriate to mitigate any hazards that could be identified in the risk assessment as unacceptable.

A.1.5 Data and analysis that documents equivalency with the intent of this standard should be prepared and submitted to the AHJ.

Δ A.3.2.1 Approved. The National Fire Protection Association does not approve, inspect, or certify any installations, procedures, equipment, or materials nor does it approve or evaluate testing laboratories. In determining the acceptability of installations or procedures, equipment, or materials, the "authority having jurisdiction" may base acceptance on compliance with *NFPA* or other appropriate standards. In the absence of such standards, said authority may require evidence of proper installation, procedure, or use. The "authority having jurisdiction" may also refer to the listings or labeling practices of an organization that is concerned with product evaluations and is thus in

a position to determine compliance with appropriate standards for the current production of listed items.

A.3.2.2 Authority Having Jurisdiction (AHJ). The phrase “authority having jurisdiction,” or its acronym AHJ, is used in NFPA standards in a broad manner because jurisdictions and approval agencies vary, as do their responsibilities. Where public safety is primary, the authority having jurisdiction may be a federal, state, local, or other regional department or individual such as a fire chief; fire marshal; chief of a fire prevention bureau, labor department, or health department; building official; electrical inspector; or others having statutory authority. For insurance purposes, an insurance inspection department, rating bureau, or other insurance company representative may be the authority having jurisdiction. In many circumstances, the property owner or his or her designated agent assumes the role of the authority having jurisdiction; at government installations, the commanding officer or departmental official may be the authority having jurisdiction.

A.3.2.4 Listed. The means for identifying listed equipment may vary for each organization concerned with product evaluation; some organizations do not recognize equipment as listed unless it is also labeled. The authority having jurisdiction should utilize the system employed by the listing organization to identify a listed product.

A.3.3.1 Apartment Building. NFPA 101 specifies that, wherever there are three or more living units in a building, the building is considered an apartment building and is required to comply with either the provision of Chapter 30 or Chapter 31 of NFPA 101, as appropriate. Townhouse units are considered to be apartment buildings if there are three or more units in the building. The type of wall required between units in order to consider them to be separate buildings is normally established by the authority having jurisdiction. If the units are separated by a wall of sufficient fire resistance and structural integrity to be considered as separate buildings, then the provisions of Chapter 24 of NFPA 101 apply to each townhouse. Condominium status is a form of ownership, not occupancy; for example, there are condominium warehouses, condominium apartments, and condominium offices. [101, 2021]

A.3.3.2.1 Flow Battery. Typically, a flow battery includes storage tanks and pumps.

A.3.3.3 Battery Management System (BMS). The BMS can include functions necessary to control charging, discharging, thermal management, shutdown, and mitigation in both normal and abnormal conditions. The BMS can be completely independent of the ESMS.

A.3.3.5.1 One- and Two-Family Dwelling Unit. The application statement of 24.1.1.1 of NFPA 101 limits each dwelling unit to being “occupied by members of a single family with not more than three outsiders.” NFPA 101 does not define the term *family*. The definition of family is subject to federal, state, and local regulations and might not be restricted to a person or a couple (two people) and their children. The following examples aid in differentiating between a single-family dwelling and a lodging or rooming house:

- (1) An individual or a couple (two people) who rent a house from a landlord and then sublease space for up to three individuals should be considered a family renting to a maximum of three outsiders, and the house should be

regulated as a single-family dwelling in accordance with Chapter 24 of NFPA 101.

- (2) A house rented from a landlord by an individual or a couple (two people) in which space is subleased to 4 or more individuals, but not more than 16, should be considered and regulated as a lodging or rooming house in accordance with Chapter 26 of NFPA 101.
- (3) A residential building that is occupied by 4 or more individuals, but not more than 16, each renting from a landlord, without separate cooking facilities, should be considered and regulated as a lodging or rooming house in accordance with Chapter 26 of NFPA 101.

[101, 2021]

A.3.3.7 Electrochemical Double Layer Capacitor (EDLC). These capacitors can also be referred to as ultra-capacitors, super capacitors, double layer capacitors, electrochemical capacitors, and so forth.

A.3.3.8 Energy Storage Management System (ESMS). Some standards refer to this as an energy management system (EMS). This system can control one or more individual management systems, such as battery management systems (BMS).

A.3.3.9 Energy Storage Systems (ESS). ESS include but are not limited to the following categories:

- (1) Chemical: hydrogen storage
- (2) Thermal: thermal energy storage
- (3) Electrochemical:
 - (a) Batteries
 - (b) Flow batteries
- (4) Mechanical:
 - (a) Flywheel
 - (b) Pumped hydro
 - (c) Compressed air energy storage (CAES)
- (5) Electrical:
 - (a) Capacitors
 - (b) Superconducting magnetic energy storage (SMES)

These systems can have ac or dc output for utilization and can include inverters and converters to change stored energy into electrical energy. It is not the intention for ESS to include energy generation systems.

Energy storage systems can include, but are not limited to, batteries, capacitors, and kinetic energy devices (e.g., flywheels). Energy storage systems can include inverters or converters to change voltage levels or to make a change between an ac or a dc system. These systems differ from other storage systems such as a UPS system, which is a power supply used to provide alternating current power to a load for some period of time in the event of a power failure.

A.3.3.9.1.1 Electrochemical Energy Storage System. The electrochemical energy is related to fuel cells, photoelectrochemical cells, and systems such as batteries.

A.3.3.9.1.2 Mechanical Energy Storage System. The mechanical energy is related to fly wheels, pump storage, compressed air systems, and systems such as reservoirs, pressure vessels, or magnets.

A.3.3.13 Flywheel Energy Storage System (FESS). There are primarily two types of rotor constructions—solid-metal-mass design and composite fiber design.

N A.3.3.13.1 Braking. Power generated from the rotor is consumed by the internal losses of the FESS. Braking can be done in a manner to create significant rotor losses to reduce braking time.

N A.3.3.13.2 Spin Down. A complete stop of the flywheel rotor cannot occur instantaneously because of the high kinetic energy of the rotor, but rather occurs over time due to a gradual slowdown to a stop as a result friction forces acting on the rotor. During spin down, active unloading, such as magnetic bearings might or might not be present.

N A.3.3.22 Repurposed Battery. An example of a repurposed battery is a stationary energy storage battery that has been built using used electric vehicle batteries, modules, or cells. Another term for a repurposed battery is *second-life battery*.

N A.3.3.26 Thermal Runaway. Thermal runaway progresses when the cell's generation of heat is at a higher rate than the heat it can dissipate.

A.4.1 Chapter 4 requirements are intended to be applicable to all ESS technologies. However, it is recognized that hazards and mitigation requirements differ among the various ESS technologies covered by Chapters 9 through 15. This section allows requirements in those chapters to supplement or supersede the general requirements of Chapter 4.

ESS should comply with NFPA 111 where adopted and where intended for use as a stored-energy emergency power supply system (SEPS).

A.4.2.3(3) The term personnel can refer to a call center, an individual, or department that has responsibility for the operation and maintenance of the ESS.

A.4.3.1 NFPA 1620 provides criteria for developing pre-incident plans for use by personnel responding to emergencies. It can be a useful resource to help in the development of pre-incident plans to assist personnel in effectively managing incidents and events for the protection of occupants, responding personnel, property, and the environment.

A.4.3.2.1.4(3) The energy storage management system (ESMS) monitors and responds to a variety of normal out-of-range conditions from the BMS or other monitoring devices in the system or installation. Many of these conditions are associated with routine operating conditions, such as battery or module temperatures, state of charge, voltages, and currents. Decisions about when and how much to charge/discharge the batteries are typically delegated to the ESMS or charger, while the BMS is responsible for enforcing a safe operating window for the batteries. Often, the BMS has direct control of an interrupt device that isolates the battery from potential or hazardous operation. Additionally, the BMS can elevate warnings or alarms to the ESMS, which is then responsible for appropriately restricting operation. Other important functions of an ESMS are the recording of data, alarms, and condition/events into a history log and managing or monitoring communications between all subsystems. Notification of elevated conditions can go to a control/monitoring center for evaluation, with some resulting in the control/monitoring center notifying the fire department or other responding organization. All conditions that necessitate such a notification along with their recommended responses should be included in the facility emergency operations plan.

A.4.3.2.1.4(4) Procedures can include sounding the alarm, notifying the fire department, evacuating personnel, de-energizing equipment, and controlling and extinguishing the fire.

Δ A.4.4.1 One form of hazard mitigation analysis (HMA) is a failure mode and effects analysis (FMEA), which is a systematic technique for failure analysis. An FMEA is often the first step of a system reliability study and involves reviewing as many components, assemblies, and subsystems as possible to identify failure modes and their causes and effects. For each component, the failure modes and their resulting effects on the rest of the system are recorded. Other formal methodologies for conducting the analysis can also be used depending on the complexity and type of the system being assessed. Guidance for analysis can be found in the following standards:

- (1) IEC 60812
- (2) IEC 61025
- (3) MIL-STD-1629A

The mixing of lead-acid batteries with nickel-cadmium batteries should not present a risk of adverse interaction. An HMA might not be necessary for these installations.

Many ESS will be provided with safety equipment to meet the requirements of UL 9540, but in some circumstances additional safety equipment might need to be provided over and above what is included with the ESS. For example, an ESS installed indoors might depend upon exhaust ventilation provided with the installation in accordance with 9.6.5.1 to remove gases from the building. In this case, the HMA would need to address possible failures of such a system. It is not the intent of the HMA to evaluate the safety equipment provided as part of a listed ESS unless that equipment is installation dependent as determined by the testing to UL 9540 and UL 9540A.

N A.4.4.2.1 Failures modes covered by 4.4.2 can include mechanical failure modes and are applicable to flywheel, stored pressure, and other types of ESS other than electrochemical ESS.

A.4.4.5 In order for the ESS to comply with the hazard mitigation analysis acceptance criteria, the building owner could be requested to provide construction, equipment, and protection systems in addition to those identified in this standard. This section clarifies that these protection measures must be installed, tested, and maintained in accordance with nationally recognized standards.

A.4.6.1 It is envisioned that equipment provided will be listed in accordance with UL 9540. ESS that are not listed in accordance with UL 9540 should be documented and verified as meeting the provisions of this standard using the equivalency requirements in Section 1.5, where technical documentation provided shows the ESS that is proposed results in a system that is no less safe than a system meeting the construction and performance requirements of UL 9540. If nonlisted equipment is to be evaluated for compliance with UL 9540, the evaluation and documentation should be provided as part of a field evaluation conducted by an approved third-party certification organization.

In specific instances, this standard will not require equipment such as lead-acid batteries to be listed or they can be listed to UL 1973 instead of UL 9540.

N A.4.6.3.2 Paragraph 4.6.3.2 aligns with 90.2(B)(4) of *NFPA 70*.

N A.4.6.9.1 UL 9540 requires inverters, chargers, and charge control equipment that are part of an ESS to be designed and rated for use with the battery system employed in the ESS and evaluated to UL 1741, UL 62109-1, CAN/CSA C22.2 No. 62109-1, UL 1012, UL 1778, or CAN/CSA C22.2 No. 107.1 as applicable to the power conversion equipment and its application in the system. UL 9540 also requires power conditioning systems for standalone and multi-mode applications to comply with UL 1741, UL 62109-1, CAN/CSA C22.2 No. 62109-1, or CSA C22.2 No. 107.1.

A.4.6.9.2 A utility-interactive inverter forms a protective barrier between the dc power source side of the inverter and the ac utility interface. In the event of an out-of-tolerance utility connection, the inverter shuts down the ac output to the utility grid. Inverters and converters might have to meet the requirements of IEEE 1547 if required by the utility interconnection requirements for ESS paralleled with the utility system.

A.4.6.10 The most common form of energy storage management system is a battery management system that plays a critical role in verifying that the system parameters identified are maintained within safe values for the ESS technology involved. In addition to shutting down the system, the ESMS can also transmit system status conditions to on-site and off-site personnel to notify them of the off-normal condition.

Δ A.4.6.11 It is not the intent of 4.6.11 to address the presence of toxic and highly toxic gases that are produced during abnormal conditions, such as a fire in the building.

N A.4.7.1 Installations of communications equipment, including batteries, under the exclusive control of communications utilities located outdoors or in building spaces used exclusively for such installations are not covered by *NFPA 70* and need not comply with the requirements of *NFPA 70*.

Adequate working space is vital for electrical safety-related work practices. Articles 110 and 706 of *NFPA 70* provide working space requirements for electrical equipment. NECA 416 is another installation standard that provides guidelines for working space requirements.

A.4.7.4 Signage provides important information for firefighters and emergency responders who respond to a fire or other incident in a building or facility in which ESS is contained. Being able to quickly understand the following is critical to maintain their safety:

- (1) The presence and location of multiple disconnects that can be used to de-energize and isolate portions of the electrical system
- (2) The location of ESS rooms and areas and the types of ESS within the room or area
- (3) Significant hazards associated with the ESS technology present

The intent of this standard is to allow flexibility in the exact wording used on required signage so conflicts are not created with other codes and standards.

Some jurisdictions can choose to supplement these required markings with *NFPA 704* hazard identification system markings or the firefighter safety building marking system described in Annex E of *NFPA 1*. However, some ESS technologies have hazards not clearly categorized in the hazard ranking system or present no hazards.

A.4.7.4.2 This sign can be broken into multiple segments. An example of this would be if the manufacturer provides their own separate signage about the fire suppression system.

A.4.7.5.3 Guard post spacing can be required with greater spacing requirements based on location.

A.4.7.5.4 ESS installed in residential garages should not be installed in a location where a motor vehicle being parked in the garage could come in contact with the ESS. Protection can be provided by approved barriers, by locating the ESS upon a 6 in. (152.4 mm) high platform located to the side of the garage, by locating the ESS components at a level above the potential impact height, or by recessing the ESS to one side of the space where the garage door is not the full width of the garage.

N A.4.7.7.3(1) Paragraph 4.7.7.3(1) aligns with 90.2(D)(4) of *NFPA 70*.

A.4.7.7.3(2) This is in line with the scope of 90.2(D)(5) of *NFPA 70* and applies to lead-acid or nickel-cadmium batteries.

A.4.7.12 Classified areas might contain hazardous and flammable atmospheres that could damage an ESS installation. ESS installations might also provide an ignition source for these atmospheres unless properly listed. See *NFPA 70*, IEEE C2, *NFPA 497*, or *NFPA 499* for more information.

N A.4.8.1 Very early warning smoke detection systems can provide an earlier indication of a potential fire with an ESS.

For lithium-ion ESS, a smoke detection system can be supplemented by a listed or approved off-gas detection system. Off-gas detection can increase the effectiveness of the smoke detection system for providing early response of an off-normal condition.

Gas detection technology can also provide additional information on conditions inside the ESS enclosure.

Δ A.4.8.1.1 Paragraph 4.8.1.1 aligns with 90.2(B)(4) of *NFPA 70*.

This requirement is intended to address small, normally unoccupied structures in remote locations, such as repeater stations, which are not adjacent to other important buildings or structures. It is not intended to apply to structures in an urban or suburban setting. The AHJ determines which structures are considered remote. The hardship of installing and maintaining smoke detection in these small, remote structures, along with heating and cooling to maintain the smoke detectors within listing specifications, is a reason for this exclusion.

See *NFPA 76* for more information on fire detection for telecommunications structures.

Δ A.4.8.1.2 Paragraph 4.8.1.2 aligns with the scope of 90.2(D)(5) of *NFPA 70*.

N A.4.8.2.2 As part of the smoke detection system's local annunciation, providing a fire alarm annunciation panel for emergency responders in an approved location where it can annunciate the ESS(s) being monitored should be considered. The location and information provided should be covered by the emergency operations plan required by 4.3.2.1 and evaluated as part of the HMA.

N A.4.8.3 The HMA or deflagration evaluation study in conjunction with UL 9540A or fire and explosion test data will be used to support the requirement for additional power supply backup

above and beyond *NFPA 72* requirements. This requirement applies to lithium-ion technologies because testing and actual events have shown that events can be several hours in duration. The additional backup will allow first responders to monitor situational conditions for longer periods of time.

Δ A.4.9.1 Fire control and suppression is only required to protect ESS when so specified elsewhere in the standard, such as Table 9.5.1, Table 9.5.2, and Table 9.5.3.1.

The fire control and suppression systems requirements in this section are intended to provide protection in ESS rooms and outdoor walk-in units containing ESS. The protection serves the following two purposes:

- (1) Protect the building and nearby exposures from a fire initiating in the ESS
- (2) Provide protection for ESS from an external exposure fire that impinges on the ESS

A phased approach to suppression can mitigate failure points and limit fire impacts that can potentially lead to thermal runaway or other more severe fire conditions.

NA.4.9.1.1 Paragraph 4.9.1.1 aligns with 90.2(B) (4) of *NFPA 70*.

A.4.9.1.3 This is in line with the scope of 90.2(D) (5) of *NFPA 70* and applies to lead-acid or nickel-cadmium batteries.

A.4.9.2.2 UL 9540A Installation Level Test, Method 1, provides the data needed to determine if automatic sprinkler design densities can be changed. A sprinkler density in excess of 0.3 gpm/ft² (12.2 mm/min) can be necessary to provide an adequate level of protection, especially for some lithium-ion battery ESS designs. However, test results for some ESS designs and technologies indicate sprinkler densities less than 0.3 gpm/ft² (12.2 mm/min) could be acceptable. Equivalent test standards, as permitted in 9.1.5, might provide comparable data.

A.4.9.3.1 UL 9540A Installation Level Test, Method 2, provides the data needed to determine if other fixed fire control and suppression systems are suitable for the application. Equivalent test standards, as permitted in 9.1.5, can provide comparable data.

Δ A.4.9.3.2 *Gaseous Agents*. Gaseous agent fire suppression systems can be used to protect ESS fires in either of the following two ways:

- (1) Total flooding systems are used where there is a permanent enclosure around the fire hazard that is adequate to enable the design concentration to be built up and maintained for the time required to ensure the complete and permanent extinguishment of a fire for the specific combustible materials involved. For total flooding systems, potential leakage sources should be included in the gaseous agent design quantities, which should include leakage through ventilation dampers. Usually, ventilation dampers are either gravity actuated (i.e., close when the ventilation fans automatically shut down upon gaseous agent discharge) or pressure actuated (i.e., close by means of counterweight and a pressure-operated latch that is activated by the gaseous agent). Leakage from the interface between the enclosure walls and the foundation should also be taken into consideration. For ESS enclosures where the normal temperature of the enclosure exceeds 200°F (93°C) or is below 0°F (-18°C), gaseous agent levels should be adjusted as required by the appropriate

NFPA standard or the manufacturer's instruction manual.

- (2) Local application systems are used for the extinguishment of surface fires of combustible gases, liquids, or solids where the fire hazard is not enclosed or where the enclosure does not conform to the requirements for a total flooding system. For local application systems, it is imperative that the entire fire hazard be protected. The hazard area should include all areas that are subject to spillage, leakage, splashing, condensation, and so forth and are of combustible materials that might extend a fire outside the protected area or lead a fire into the protected area. This type of hazard could necessitate dikes, drains, or trenches to contain any combustible material leakage. When multiple ESS equipment fire hazards are in an area such that they are interposing, provisions should be made to ensure that the hazards can be protected simultaneously, which could involve subdividing the hazards into sections and providing independent protection to each section.

See G.6.1.4 for more information on the use of gaseous/lean agent fire suppression with LIB-based ESS.

Water Mist. Water mist fire suppression systems need to be designed specifically for use with the size and configuration of the specific ESS installation or enclosure being protected. Currently there is no generic design method recognized for water mist systems. System features such as nozzle spacing, flow rate, drop size distribution, cone angle, and other characteristics need to be determined for each manufacturer's system through fire and explosion testing in accordance with 9.1.5 to obtain a listing for each specific application and must be designed, installed, and tested in accordance with *NFPA 750*.

See G.6.1.3 for more information on the use of water mist systems with LIB-based ESS.

A.4.9.4.1 Water supplies could be one or any combination of the following:

- (1) A connection to an approved public or private waterworks system
- (2) A connection including a fire pump
- (3) A connection to a water storage tank at grade or below grade installed in accordance with *NFPA 22* and filled from an approved source
- (4) A connection to a pressure tank and filled from an approved source
- (5) A connection to a gravity tank and filled from an approved source
- (6) A penstock, flume, river, lake, pond, or reservoir
- (7) A cistern
- (8) A source of recycled or reclaimed water where the building owner (or their agent) has analyzed the water source and the treatment process (if any) that the water undergoes before being made available and determined that any materials, chemicals, or contaminants in the water will not be detrimental to the components with which it is in contact

NA.5.4 There are a number of requirements for protective features to be built into the ESS or buildings that house ESS. Consideration should be given to provide for the grouping of systems, controls, and monitoring for safe access for those who respond to these incidents as approved by the AHJ. The location can include FACP annunciation to include, fire, trouble,

supervisory, dry standpipe hose connection, e-stop, remote ventilation control, and high-gas notification.

A.6.1.1.2 The North American Electric Reliability Corporation (NERC) and Federal Energy Regulatory Commission (FERC) are two examples of entities that have, or are developing, commissioning requirements for electric utilities ESS installations that form the basis for governmental laws and regulations.

A.6.4 After an ESS is commissioned and put into operation, it becomes an existing system. There could come a time when that existing system or impacted portion of a system is altered, repositioned, added to, renovated, or in some way modified beyond simple service or replacement of in-kind parts and components. When any of those activities are conducted on the system, there is no documentation or verification that the system will properly operate (e.g., the original commissioning plan and commissioning report would not necessarily support the system since it was modified in some way by one or more of these activities). That necessitates the resultant system be commissioned again. While the term recommissioning might be used in this case, that term can also be used to describe the conduct (again) of an initial commissioning activity on a new system where that initial commissioning process failed and was redone. With respect to an existing system or impacted portion of a system that has been modified in some way, the intent of the standard is simply to recommission the system in accordance with the recommissioning requirements in Section 6.4.

A.6.4.2 Listed software changes should be considered system renewals because it is a listed change.

A.6.4.4 When listed ESS is modified in the field, it can change its ability to comply with the requirements in the standard used to list the product. It is difficult or impossible for AHJs and service personnel to verify that the modified product complies with those requirements. Certification organizations have the expertise to evaluate modifications and have field evaluation programs to investigate the modified product and provide a field evaluation label on the product. It is not anticipated that a field evaluation is needed to evaluate modifications that are identified in the instruction manual provided with the listed equipment, such as swapping out or adding listed modules. It is also not anticipated that a field evaluation is needed for like-for-like repairs that do not impair the overall safety of the product.

A.7.1.2(5) Examples of engineering documentation include one-line diagrams, lock-out/tag-out procedures, and shock and arc flash labeling.

NA.7.2 IEEE 3007.1 provides guidance on ESS maintenance.

A.8.1.2 The North American Electric Reliability Corporation (NERC) and Federal Energy Regulatory Commission (FERC) are two examples of entities that have, or might be developing, decommissioning requirements of ESS installations for electric utilities that form the basis for governmental laws and regulations.

A.8.1.3 Considerations that should be included in the decommissioning plan would include but not be limited to the following:

- (1) An identification of all energy sources (batteries, connected batteries in other enclosures or structures), inverters [also known as *power conversion systems* (PCS)], dc bus precharge power supplies, UPS, support equip-

ment with batteries, and ac or dc auxiliary power equipment and distribution systems

- (2) Information about PPE and requirements for use as needed (site dependent), noting that each electrical equipment cabinet should already have shock and arc flash warning labels applied as per NFPA 70E
- (3) A notification that the ESS should be discharged to its safe state of charge (SOC) for transport
- (4) Assurance that during the decommissioning process, critical support equipment such as, but not limited to, fire detection and suppression equipment, emergency lighting, electrical circuits to facilitate decommissioning, and so forth, remain operational to the extent possible
- (5) A warning not to disconnect any ESS grounding until all energy sources are isolated and locked out
- (6) A notification to disconnect and shut down all batteries and support or auxiliary equipment associated with the system or its component parts
- (7) Isolation of all energy sources, starting with those with highest fault energy, by isolating the ac point of interconnection, then isolating strings, then isolating the individual battery modules
- (8) The need to mechanically uninstall battery trays and place them into original or equivalent packing materials or protect terminals
- (9) Assurance that the materials are properly classified and packaged based on regulations governing the classification before removing material from the site (e.g., requirement that shipments on public roads comply with DOT regulations, including UN/DOT 38.3-tested packing for Li-ion batteries and UN 2800 for VRLA nonspillable batteries)
- (10) The need to remove batteries from other equipment associated with the system as part of decommissioning and prior to removal

A.9.1.1 Annex B includes information on general hazards associated with ESS. Section B.5 provides a description of commercially available battery technologies and the hazards associated with them.

NA.9.1.3 Capacitors used for utility applications that are not included in this chapter for capacitor ESS are typically technologies that have metallized film electrodes with a polymer film (polypropylene) and aromatic hydrocarbon fluid dielectric and are referred to as metallized film capacitors or all film capacitors.

ΔA.9.1.5.1 A UL 9540A test or equivalent test should evaluate the fire characteristics of the composition of gases generated at cell level, module level, and unit and installation levels for an indoor installation of an ESS that undergoes thermal runaway, such as what might occur due to a fault, physical damage, or exposure hazard. The evaluation of the fire characteristics during fire vent testing at the unit level and indoor installation level testing should document whether the fire event propagates to the neighboring ESS units and include radiant heat flux measurements at enclosing wall surfaces and at various distances from the ESS being tested at the unit level. The data generated by the fire and explosion testing is intended to be used by manufacturers, system designers, and AHJs to determine the need for fire and explosion protection required for an ESS installation.

NA.9.1.5.1.3 Changes in an installation configuration, including the internal architecture of modules and units, that don't

match the parameters tested, such as size and separation, cell type, or energy density, should not be accepted unless it can be shown that the configuration provides equivalent results. For example, scaling such as height, depth, and spacing need to conform to the configuration of the test. Changes also might include multiple levels of units on top of each other, located on a mezzanine floor above, or back-to-back units. These configurations might not have been evaluated in the test.

A.9.1.5.2 The test report will provide nonproprietary information that, among other things, describes the size and energy capacity rating of the unit being tested, model numbers of the modules and ESS units, orientation of ESS in the test facility, and proximity of the ESS unit under test to adjacent ESS, walls, and monitoring sensors. The test report also includes a complete set of test results and measurements. For example, a complete UL 9540A test report that includes a unit level test should also include the UL 9540A cell and module level test.

N A.9.2.1.2.1 Lead-acid and nickel-cadmium batteries listed to UL 1973 are often assembled with listed chargers and other listed components for use in stationary standby applications. In these instances, listing at the system level to UL 9540 might not be necessary for installations less than 600 V dc.

N A.9.2.1.2.2 Paragraph 9.2.1.2.2 aligns with 90.2(D)(4) of *NFPA 70*.

A.9.2.1.2.3 This subsection is in line with the scope of 90.2(D)(5) of *NFPA 70* and applies to lead-acid or nickel-cadmium batteries.

N A.9.2.3.1 Where the ESS operates in parallel to the electric utility grid, the ESMS or BMS should meet the operating requirements of the utility interconnection and any minimum legal requirements.

Lead-acid and nickel cadmium battery systems typically do not require or include an ESMS or BMS.

N A.9.2.3.2 Annex B provides a partial list of potential hazard conditions, which can vary for each ESS type.

A.9.2.3.3 Local visible annunciation, when required by the AHJ, is intended to provide on-scene emergency responders with information about potentially hazardous conditions with the ESS so appropriate deployment tactics can be taken. It is not the intent of this section to require the ESMS to transmit alarm signals to an off-site locale. The ESS manufacturer is most qualified to identify conditions with its equipment that constitutes a hazardous, not just abnormal, condition. These conditions typically include high temperature but might also include other conditions such as overcharge, short circuit, etc. The AHJ should consult with individuals responsible for the system to verify that the conditions used to identify a hazardous condition are understood and acceptable, and the location of the unit in trouble is adequately identified.

Visible annunciation can consist of a colored light on an ESS unit, an annunciation panel, or other approved means.

N A.9.2.3.4.1 Paragraph 9.2.3.4.1 aligns with 90.2(B)(4) of *NFPA 70*.

A.9.2.3.4.2 This is in line with the scope of 90.2(D)(5) of *NFPA 70* and applies to lead-acid or nickel-cadmium batteries.

N A.9.2.4.2 UL 1974 is a factory process standard that covers the sorting and grading process of battery packs, modules and

cells, and electrochemical capacitors that were originally configured and used for other purposes, such as electric vehicle propulsion, and that are intended for a repurposed-use application, such as for use in energy storage systems. It includes requirements for quality control for factory facilities and processes such as sorting and grading, testing, and marking criteria for the batteries that are to be used in a new battery assembly. This standard is used for a facility process certification similar to ISO 9001. A battery that goes through this process is not a listed battery unless it is additionally evaluated to a safety standard such as UL 1973.

A.9.4.2 This section includes requirements designed to keep fires originating in a single energy storage unit from easily spreading to adjacent energy storage units or out of the fire area in which the ESS is installed. This is done by limiting potential fire size within an individual energy storage unit by limiting the total energy capacity of individual units. It also reduces the potential of fire originating in one unit from igniting an adjacent unit, or breaching a fire-resistance-rated wall through radiant heat transfer by requiring spacing between individual energy storage units, and between units and walls. An option is provided for increasing individual unit energy capacity or reducing spacing by successfully passing fire and explosion testing in accordance with 9.1.5.

The following two levels of compliance can be considered with regards to size and separation:

- (1) The ESS meets the group size and separation requirements of 9.4.2.1 and 9.4.2.2.
- (2) The ESS exceeds the group size limit of 9.4.2.1, or has spacings smaller than 9.4.2.2, but remains constrained to the limits determined by the fire and explosion testing of 9.1.5. This option is based on the review and acceptance of test data by the AHJ as required by 9.4.2.3.

N A.9.4.2.4.1 Paragraph 9.4.2.4.1 aligns with 90.2(D)(4) of *NFPA 70*.

A.9.4.2.4.2 This is in line with the scope of 90.2(D)(5) of *NFPA 70* and applies to lead-acid or nickel-cadmium batteries.

A.9.5.1.2.1 An occupied work center is typically an area in which stationary battery systems are provided in an electronic equipment or computer room with occupiable space. Personnel in these locations are not responsible for maintaining or servicing the battery systems. The requirements in this section are provided to help ensure their safety and the safety of emergency responders dispatched to the work area.

A.9.5.2.3.2 Walk-in ESS are units where personnel can enter the enclosure or container housing the system or system components for any reason. This includes ESS enclosed within an outer enclosure similar to an ISO shipping container. It does not include ESS cabinets where personnel can partially enter into the outer enclosure to perform service or maintenance.

N A.9.6.2.2.3 Paragraph 9.6.2.2.3 is in line with the scope of 90.2(D)(5) of *NFPA 70*.

N A.9.6.3.2.1 Paragraph 9.6.3.2.1 aligns with 90.2(D)(4) of *NFPA 70*.

Δ A.9.6.5.1 This section addresses hazards associated with the release of flammable gases from ESS during normal charging, discharging, and use conditions. Similar requirements have been in fire codes for many years primarily to address off-

gassing of hydrogen from stationary vented lead-acid battery systems but not limited to that technology.

This section is not intended to provide protection against the release of flammable gases during abnormal charging or thermal runaway conditions. Those conditions are addressed in 9.6.5.6. In addition, this section does not regulate ventilation of toxic and highly toxic gases, which are regulated by 4.6.11.

A.9.6.5.1.4 Initial charging of new batteries can produce more hydrogen than operational boost charging. It is advisable to calculate or obtain hydrogen production numbers for this operational mode and determine if existing ventilation is adequate or temporary supplemental ventilation is needed. See IEEE 1635/ASHRAE 21, which covers the ventilation of stationary battery systems utilizing vented (flooded) lead-acid, valve-regulated lead-acid (VRLA), and nickel-cadmium (Ni-Cad) batteries.

NA.9.6.5.1.5.4 Possible standards to which gas detectors might be approved or listed include UL 2075 and FM 6325.

The purpose of the gas detector is to initiate ventilation that will remove flammable gases from the installation area before a flammable atmosphere is reached. Note that for most lead-acid and Ni-Cd installations, calculated hydrogen release under normal float charging or even boost charging is relatively small and easily handled by normal occupancy type ventilation requirements, therefore use of a hydrogen detector for these spaces is often not even recommended (see IEEE 1635/ASHRAE 21). If a gas detector is used, its selection and location should be analyzed with the following considerations:

- (1) Detected gas
- (2) Response time
- (3) Ambient airflow
- (4) Vulnerability to fouling, poisoning, or drift
- (5) Required maintenance

Detected Gas. The detector should be selected to sense hydrogen since this is the only flammable gas that aqueous batteries (e.g., lead-acid, Ni-Cd, Ni-Zn) release under normal operation. Nonaqueous technologies, like lithium-ion and NaNiCl, do not normally release gas except for under thermal runaway conditions. See 9.6.5.6 for ventilation recommendations for abnormal conditions like thermal runaway.

Response Time. The detector should be selected to minimize the response time to initiate ventilation. Factors that can impact response time include the distance for the air-gas mixture to travel to the detector, the length of the sample tube (if applicable), the type of detector, and the analysis process. Detectors can be listed with response times of under a minute to several minutes. Because hydrogen molecules—being small—disperse fairly quickly and spread relatively evenly throughout the environment, and because the alarming and action threshold is at 25 percent of the LFL (and the LEL is even higher than the LFL by at least a factor of 2), hydrogen sensors should be placed between 1 m to 2 m (3 ft to 6 ft) from the battery vents to avoid unnecessary alarms and in accordance with the battery manufacturer's instructions.

Ambient Airflow. There are several documents that provide qualitative guidance on the number and location of gas detectors in process areas (e.g., EN 60079-29-16-1), performance requirements of detectors for flammable gases (e.g., ISA TR84.00.07), and monitoring for hazardous material release (e.g., CGPS publication *Continuous Monitoring for Hazardous*

Material Releases). These documents provide guidance on the most common approaches to gas detector placement, including target gas cloud and scenario-based monitoring.

Vulnerability to Fouling, Poisoning, and Drift. Note that not all combustible and toxic gas-sensing technologies are equal. Some are more sensitive than others to fouling (i.e., misreading and/or failure) from cross-contamination with other gases that might be present. Note that the largest quantities of gases produced during a lithium-ion fire are hydrogen, carbon monoxide, and carbon dioxide. The environment where the ESS is installed should be assessed to determine the likely presence of any other gases that could foul or poison a catalytic bead-type sensor or an electrochemical detector. The sampling tube size, where used, should consider particulate concentration in the ambient that could clog the tube if not maintained regularly. Some detectors must be "bump tested"—exposed to a small amount of the calibration gas—to ensure the sensor continues to sense the target gas at the desired concentration.

Required Maintenance. All detectors require routine maintenance to ensure continued proper function. The manufacturer's guidelines should be followed for regular calibration, bump testing (if needed), and sample tube cleaning. The recommended intervals for such maintenance vary from 1 to 12 months, depending on the type and manufacturer of the device. Designers and installers should ensure that end users are aware of the maintenance requirements and manufacturer's instructions. Calibration should only be conducted by qualified personnel, and only with the target gas.

Note that because hydrogen molecules are very small, they tend to disperse rapidly. Hydrogen will initially head to the ceiling. Research by NIST (see GCR-10-929), Sandia National Labs (see SAND2019-7454C), the Netherlands Institute for Safety (see IFV 20210209), and many others indicates that gas concentration will be detectable throughout the room over a reasonable time period; therefore, placement of the hydrogen sensors should be at an easily-accessible location in the battery area [within 2 m (6 ft) of the batteries] instead of near a high ceiling in order to facilitate the relatively frequent maintenance required for the sensors.

A.9.6.5.2.2 Methods of achieving this protection can include, but are not limited to, the following:

- (1) Liquidtight sloped or recessed floors in indoor locations or similar areas in outdoor locations
- (2) Liquidtight floors in indoor locations or similar areas in outdoor locations provided with liquidtight raised or recessed sills or dikes
- (3) Sumps and collection systems

A.9.6.5.3.1 One method to determine compliance with the neutralization requirements of this subsection is found in UL Subject 2436. UL Subject 2436 investigates the liquid tightness, level of electrolyte absorption, pH neutralization capability, and flame spread resistance of spill containment systems.

NA.9.6.5.4 If recombination caps are used they should contain evaluated flame arresters.

NA.9.6.5.5 A component of the thermal runaway protection might be integrated within the ESS battery management system or ESS management system that controls the charging and discharging to keep the ESS within its normal/safe operating limits when that device has been evaluated with the batteries or capacitors as part of the listing to UL 1973 or UL 9540, as appli-

cable. The device might also initiate appropriate hazard mitigation as required elsewhere in this standard when the ESS is in an abnormal state such as overheating or off-gassing.

Δ A.9.6.5.6 During failure conditions such as thermal runaway, fire, and abnormal faults, some ESS, in particular electrochemical batteries and capacitors, begin off-gassing flammable and toxic gases, which can include mixtures of CO, H₂, ethylene, methane, benzene, HF, HCl, and HCN. Among other things, these gases present an explosion hazard that needs to be mitigated. Explosion control is provided to mitigate this hazard.

Both the exhaust ventilation requirements of 9.6.5.1 and the explosion control requirements of 9.6.5.6 are designed to mitigate hazards associated with the release of flammable gases in battery rooms, ESS cabinets, and ESS walk-in units. The difference is that exhaust ventilation is intended to provide protection for flammable gases released during normal charging and discharging of battery systems since some electrochemical ESS technologies such as vented lead-acid batteries release hydrogen when charging.

In comparison, the 9.6.5.6 provisions are designed to provide protection for electrochemical ESS during an abnormal condition, such as thermal runaway, which can be instigated by physical damage, overcharging, short circuiting, and overheating of technologies such as lithium-ion batteries, which do not release detectable amounts of flammable gas during normal charging and discharging but can release significant quantities of flammable gas during a thermal event.

Δ A.9.6.5.6.3 The requirement recognizes that with some cabinet designs that have low internal volume, the application of NFPA 68 or NFPA 69 might not be practical. It is possible that a quantitative explosion analysis is necessary to show there is no threat to life and safety. For example, the cabinet design might be installed such that any overpressure due to ignition of gases and vapors released from cells in thermal runaway within the enclosure are released to the exterior of the enclosure. There should be no uncontrolled release of overpressure of the enclosure. All debris, shrapnel, or pieces of the enclosure ejected from the system should be controlled. The UL 9540A unit level and installation level test identified in 9.1.5 will provide the test data referenced in 9.6.5.6.3, which is necessary for verification of the adequacy of the engineered deflagration safety of the cabinet.

NFPA 68 applies to the design, location, installation, maintenance, and use of devices and systems that vent the combustion gases and pressures resulting from a deflagration within an enclosure so that structural and mechanical damage is minimized, and provides criteria for design, installation, and maintenance of deflagration vents and associated components. NFPA 68 does not apply to detonations. Hydrogen accumulation in a confined space can lead to a detonation. For that reason, the combustion gases generated during the cell, module, and installation level testing under UL 9540A must be used when applying a NFPA 68 solution. Where the likelihood for detonation exists, alternative solutions such as those in NFPA 69 should be considered.

NFPA 69 applies to the design, installation, operation, maintenance, and testing of systems for the prevention of explosions in enclosures that contain flammable concentrations of flammable gases, vapors, mists, dusts, or hybrid mixtures by means of the following methods:

(1) Control of oxidant concentration

- (2) Control of combustible concentration
- (3) Pre-deflagration detection and control of ignition sources
- (4) Explosion suppression
- (5) Active isolation
- (6) Passive isolation
- (7) Deflagration pressure containment
- (8) Passive explosion suppression

Combustible gas concentration reduction can be a viable mitigation strategy for possible accumulation of flammable gases during abnormal conditions for lithium-ion batteries. Gas detection and appropriate interlocks can be used based on appropriate evaluation under an NFPA 69 deflagration hazard study. NFPA 69 allows concentration to exceed 25 percent LFL but not more than 60 percent with reliable gas detection and exhaust interlocks as demonstrated by a safety integrity level (SIL) 2 instrumented safety system rating.

Data on flammable gas composition and release rates, such as that included in UL 9540A fire and explosion testing, provide the information needed to design effective explosion control systems.

Δ A.9.6.5.6.4 Currently, UL 9540A includes a pass/fail criteria requiring that no hazardous pressure waves, debris, shrapnel, or enclosure pieces are ejected during the fire and explosion testing. Engineered solutions might be an effective solution to the deflagration hazard, and engineering details are to be submitted for review and evaluation by laboratory staff prior to testing.

Hazardous pressure wave guidance for human exposure and structure exposure can be found in NFPA 921 and in a City University of New York (CUNY) guidance document found at nysolarmap.com/media/2041/fire-safety-testing-data-analysis-supplement-for-nyc-outdoor-ess_v1.pdf. For human and structure exposure, a level less than 1 psig (6.9 kPa) might be indicated by the guidance material.

Δ A.9.6.5.6.6 Possible standards to which gas detectors might be approved or listed include UL 2075 and FM 6325.

The purpose of the gas detector is to initiate ventilation that will remove flammable gases from the installation area before a flammable atmosphere is reached. Data from lithium-ion battery and module testing indicates that gas generation accelerates rapidly once the thermal runaway threshold is reached. Therefore, it is critical to initiate ventilation as early in the process as possible. Selection and location of the gas detector should be analyzed with the following considerations:

- (1) Detected gas
- (2) Response time
- (3) Ambient airflow
- (4) Vulnerability to fouling, poisoning, or drift
- (5) Required maintenance

Detected Gas. The detector should be selected to sense a gas that is likely to be present in the event of thermal runaway and in high enough quantities that the event will be identified in a timely manner. Note that while hydrogen is the primary combustible gas of concern for aqueous batteries (e.g., lead-acid, Ni-Cd, Ni-Zn), for lithium-ion batteries, multiple combustible gases are released in a thermal runaway/fire scenario. Hydrogen is usually the predominant gas generated, but significantly measurable quantities of methane, ethane, propylene, and ethylene are also produced along with trace amounts of other hydrocarbon combustible gasses (the actual mixture and

percentages of combustible gases depends on the lithium-ion chemistry).

Response Time. The detector should be selected to minimize the response time to initiate ventilation. Factors that can impact response time include the distance for the air-gas mixture to travel to the detector, the length of the sample tube (if applicable), the type of detector, and the analysis process. Detectors can be listed with response times of under a minute to several minutes. Because gas generation is known to increase over the course of a thermal runaway event, the response time of the detector itself should be in the one to three minute range.

Ambient Airflow. There are several documents that provide qualitative guidance on the number and location of gas detectors in process areas (e.g., EN 60079-29-16-1), performance requirements of detectors for flammable gases (e.g., ISA TR84.00.07), and monitoring for hazardous material release (e.g., CCPS publication *Continuous Monitoring for Hazardous Material Releases*). These documents provide guidance on the most common approaches to gas detector placement, including target gas cloud and scenario-based monitoring.

The role of airflow, particularly in "open" ESS rooms and buildings, will greatly impact the location of detectors. Many LIB installations require constant ventilation to maintain batteries within the normal operating temperature range. In indoor installation areas, the airflow patterns will be determined by the mechanical ventilation system. In these cases, there will be an exhaust or recirculation duct where well-mixed air will come in contact with the gas detector. In smaller installations, or where multiple ventilation ducts are used, detector placement in the exhaust duct could provide the best chance for rapid detection. In large installations, this might not be the ideal or the only location for a gas detector due to the longer travel time for gas mixtures from the furthest unit to reach the duct. Additional detectors arranged in a grid pattern could be recommended.

Vulnerability to Fouling, Poisoning, and Drift. Note that not all combustible and toxic gas-sensing technologies are equal. Some are more sensitive than others to fouling (i.e., misreading and/or failure) from cross-contamination with other gases that might be present. Note that the largest quantities of gases produced during a lithium-ion fire are hydrogen, carbon monoxide, and carbon dioxide. The environment where the ESS is installed should be assessed to determine the likely presence of any other gases that could foul or poison a catalytic bead-type sensor or an electrochemical detector. The sampling tube size, where used, should consider particulate concentration in the ambient that could clog the tube if not maintained regularly. Some detectors must be "bump tested"—exposed to a small amount of the calibration gas—to ensure the sensor continues to sense the target gas at the desired concentration.

Required Maintenance. All detectors require routine maintenance to ensure continued proper function. The manufacturer's guidelines should be followed for regular calibration, bump testing (if needed), and sample tube cleaning. The recommended intervals for such maintenance vary from 1 to 12 months, depending on the type and manufacturer of the device. Designers and installers should ensure that end users are aware of the maintenance requirements and manufacturer's instructions. Calibration should only be conducted by qualified personnel, and only with the target gas.

NA.9.6.6.1 Authorized service personnel should be guided by the decommissioning plan (see Section 8.1) with guidance from the emergency responders to safely mitigate any hazard created by the damage to the ESS. The authorized service personnel should be dispatched in a time established by the AHJ. This should be made a provision of the AHJ operating permit.

NA.9.6.6.2 For example, lithium-ion batteries in ESS that experience an abnormal condition, including thermal runaway, might experience reignition even though the initial fire event appears to have been extinguished. Hazard support personnel are needed on-site during this period to monitor and control the ESS and batteries until they can be placed in a safe condition. During this time, it might be appropriate to apply water for cooling and to provide ventilation. Without these measures, it is possible for heat to remain and for thermal runaway reactions to continue occurring.

This occurrence has been observed multiple times. A best practice is for the AHJ to require a fire watch by a trained person described as "hazard support personnel" that will make sure that all safety precautions and mitigation practices in place are followed. This is intended to protect the public and the building occupants from these potential fire and explosion hazards that could still exist after the initial fire is considered to be extinguished.

The ESS location should be a factor in determining whether a fire watch at the site is necessary, based on a risk assessment and the site decommissioning plan. If a fire watch is not required, the site should still be protected from any unauthorized access because even damaged ESS could still have dangerous levels of stored electrical energy.

Where an ESS is damaged by fire, the engineering safety measures that are provided for the ESS are compromised and might no longer provide the safety that is provided during normal ESS operation.

NA.9.6.6.2.1 The following hazard support personnel qualifications should be considered:

- (1) Trained by the ESS provider about the hazards of the ESS to be monitored
- (2) Knowledgeable with the ESS fire protection features
- (3) Knowledgeable with the manufacturer's emergency guide and how to access the battery

NA.9.6.6.2.4 Based on the system design and features, remote monitoring and controls that provide additional safety benefits can be used by the AHJ to determine the level of onsite monitoring required.

NA.9.6.6.2.5 Hazard support personnel should be able to provide support to the AHJ in reoccupying the space, implementing the decommissioning plan, and deenergizing the battery modules for a safe means of transportation.

Hazard support personnel are not expected to perform any fire suppression duties but can do so if properly trained and equipped.

NA.13.1.2 FESSs utilized exclusively on utility property under the jurisdiction of that utility would be evaluated to NFPA 850 as well as IEEE C2 and need not be covered by this installation standard.

- NA.13.1.3** An FESS requires ongoing inspections and maintenance that might not occur with an individual homeowner installation. A microgrid serving multiple dwellings assumes that required maintenance will be performed. Therefore, an FESS can be used as part of a multi-dwelling microgrid such as a neighborhood community solar installation.
- NA.13.2.5** Locations subject to high levels of vibration, such as near train tracks or large engine generators) can result in stress to the bearing systems and affect the safe operation of the FESS.
- NA.13.2.6** There should be capability for the ESMS to track the bearing replacement based upon length of date in service or usage (whichever comes first) and that incorporates the time the bearings are without magnetic unloading, which can reduce bearing life. The bearing monitoring can be part of the flywheel control system.
- NA.13.2.6.2** ESMS data on temperature and vibration should be stored for postfailure analysis.
- NA.13.2.8** FESS containment measures can consist of the following two methods:
- (1) Containment of the rotor
 - (2) A rotor design margin with stringent rotor screening in production, including sacrificial evaluation of rotors
- The containment of hazardous moving parts is evaluated as part of the listing evaluation and can be provided by the installation.
- The evaluation of containment should consider whether the enclosure can become pressurized during a catastrophic failure of a flywheel. In some flywheel designs, the rapid dissipation of kinetic energy into heat during rotor failure can heat liquids or other components in the housing and generate pressure. The flywheel enclosure could potentially burst if not designed to contain this pressure or equipped with pressure relief devices.
- Failure of a composite flywheel can generate particulate, which can be a combustible dust. See NFPA 652 for general guidance on managing hazards of combustible dust.
- NA.13.2.9** Some FESS can be used in a mobile application, but the rotor would need to be stopped prior to moving. Mobile FESS cannot be transported with energy in the flywheel.
- NA.13.2.12** Parts or other debris from catastrophic failure of a flywheel could damage adjacent flywheels or energy storage systems if the housing does not fully contain the failure.
- NA.13.3** Prior to operating the FESS, the following should be verified to ensure that the bolts securing the FESS are the correct grade and size, and are all torqued to specification; the concrete inserts are the correct type; the concrete support is the appropriate thickness (validate with personnel that did the coring); and the proper mechanical containment was installed, if required. As part of this process, the securement of the bolts should be reverified to ensure that they are tightened to the appropriate torque.
- NA.13.4** The bearing change interval can be either periodic or reported by the system. If reported by the system, it should be based upon actual bearing condition.
- NA.13.4.2** Vacuum leaks often get worse over time and a leak should be dealt with preemptively. With some designs of FESS, a sudden loss of vacuum can result in a rotor failure.
- NA.13.5.1** Discharging the FESS to 100 percent usually does not accomplish a complete removal of energy. In the event of a tachometer/commutation sensor feedback failure, no indication of rotor speed will be available. Flywheels can take more than 24 hours to spin down to zero rpm.
- NA.14.2.1** Batteries have been safely collected in one or two 55 gal (208 L) drums (or similarly sized bins or containers) for decades without any significant fire or life safety events.
- NA.15.1** Any detached building, or any part of a townhouse structure that is separated from the remainder of the townhouse structure with fire resistance rated assemblies in accordance with local building code, that contains no more than two dwelling units intended to be used, rented, leased, let, or hired out to be occupied or that are occupied for habitation purposes. [13D:3.3.3]
- A.15.5.4** The batteries on electric vehicles should not be included in the aggregate energy capacity limitations in 15.4.1.
- NA.15.6.2** In addition to the system connection equipment needing to be listed for utility connection, the installer needs to be aware of and comply with the local utility interconnection requirements.

Annex B Battery Energy Storage System Hazards

This annex is not a part of the requirements of this NFPA document but is included for informational purposes only.

B.1 General Introduction. Battery energy storage systems (ESS) that are designed with sufficient safety protections and are installed, operated, and maintained in a manner that maintains the system safety can be operated without incident as evidenced by the systems currently operating safely in the field. The safety controls and hazard mitigation approach needs to consider the inherent hazards associated with these systems, which can vary depending on the battery technology.

B.2 Hazards Concerns.

B.2.1 The hazards that need to be addressed for ESS are fire and explosion hazards, chemical hazards, electrical hazards, stranded or stored energy hazards, and physical hazards. These hazards can vary by technology but can also vary under normal operating conditions compared with emergency and abnormal conditions.

B.2.2 The potential for fire hazards can be evaluated through control of the elements of the fire triangle. These elements are the fuel for the fire, the oxidant, and the ignition source heat. There is no potential for fire unless there is an appropriate concentration of fuel, oxidant, and a heat source sufficient to ignite the concentration.

B.2.3 Chemical hazards are categorized in accordance with OSHA/NIOSH hazardous materials limits for normal operation of the ESS and NFPA 704 for ESS involved in a fire or other emergency incident.

B.2.4 Electrical hazards for persons working with ESS where they might come in contact with energized parts greater than 50 V and exposed to arcing of electric energy with an incident energy level of 1.2 cal/cm² (5 J/cm²) (potential to cause second-degree burns on skin), are electrical shock and arc flash as identified in NFPA 70E. Electrical hazards to emergency responders from ESS that have been exposed to fire or other emergency incidents need to be addressed, including the

potential for arc faults and shock hazards due to shorting from damaged parts and water. Since first responders are not trained electrical workers and might not have appropriate PPE for direct contact with live parts or arc flash incidents, acceptable levels of voltage and incident energy need to be reduced from that allowed for trained workers with suitable PPE.

B.2.5 The term *stranded or stored* energy refers to unquantified hazardous levels of electrical energy that can be contained in all or part of an ESS, including one that has been damaged and/or thought to be discharged and that represents a hazard to persons in contact with the system, who are unaware of the hazardous energy. Since this hazard represents a potential unquantified electrical hazard, the allowed levels will be different depending on whether it pertains to normal conditions for repair and replacement by trained workers or for emergency responders dealing with damaged ESS that can still contain hazardous energy.

B.2.6 Physical hazards are hazards to persons that can occur from contact with parts having sufficient kinetic energy, parts that have hazardous thermal characteristics that can cause burns, or parts that contain fluids at hazardous pressure levels with either insufficient structural integrity to safely contain the fluids or the ability to safely relieve the pressure. For electrochemical ESS, the potential exists for burn hazards to workers in contact with some technologies during normal operation and repair, if not properly thermally insulated.

B.2.7 There are no known high-pressure hazards with these systems under normal operations, but under abnormal conditions, there can be overpressurization due to overheating of contents, which can result in a physical hazard. This could present a hazard to first responders dealing with damaged ESS. There are also no kinetic energy hazards associated with commercially available battery ESS, except for moving parts in the balance of plant components of the system that might not be properly guarded, such as cooling or ventilation fan blades.

B.3 Hazard Considerations Under Normal Operating Conditions.

B.3.1 Fire and Explosive Hazards. Fire and explosive hazards under normal operating conditions can be due to heat sources such as live parts, and so forth, that can be in contact with combustible materials during service or maintenance or to ignition of combustible concentrations or flammable fluids and solids that can occur as part of the normal operation of ESS, such as hydrogen off-gassing from batteries with aqueous electrolytes that are open to the atmosphere.

B.3.2 Chemical Hazards. Under normal operating conditions, the potential exists for exposure to hazardous materials by workers in contact with the system for maintenance, repair, and replacement of systems. OSHA and NIOSH have guidelines on exposures to hazardous materials, including limits for workers that have the potential for exposure during normal operation maintenance, and so forth.

Examples of chemical hazards are as follows:

(1) *Liquid hazards:*

- (a) *Corrosive electrolytes:* Batteries with electrolytes in the range of pH ≤ 2 or ≥ 11.5 are considered corrosive (acid or caustic). This is an issue with systems with these electrolytes, where there can be a situation of leaks or spills during maintenance or normal operation. There should be measures for spill control,

and workers should have appropriate safe work procedures and protective clothing to work around systems with these corrosive liquids.

- (b) *Toxic liquids:* The potential exists for exposure to toxic liquids during normal operating, servicing, and maintenance of some systems. Guidance for worker exposure to toxic liquids can be found in OSHA hazardous materials guidelines. Workers in contact with these systems need to be aware of potential hazards and have appropriate procedures and equipment/PPE to avoid these hazards.
- (2) *Oxidizers:* The potential exists for oxidizers to be present within the ESS. An oxidizer will increase the flammability potential of other materials. Annex G in NFPA 400 provides information on tests to classify an oxidizer material and identifies known oxidizing materials under their classifications. Annex G in NFPA 400 also provides guidance on safety measures to use when there are significant exposed quantities of known oxidizers, which can occur during normal maintenance conditions of certain ESS technologies that contain them.
- (3) *Gases — Toxic gases:* The potential exists for exposure to toxic gases under normal conditions of maintenance and service of some ESS systems. OSHA and NIOSH provide guidance for exposures, including permissible exposure limits (PEL), recommended exposure limits (REL) for exposure during an 8- or 10-hour workday, ceiling limits, which are the upper limit of a safe exposure, and IDLH, which represents concentrations that are immediately dangerous to life and health.
- (4) *Solids:* Water-reactive and toxic metals that might be contained in some battery technologies typically are not exposed during routine maintenance and servicing of these systems but can present issues under abnormal conditions. Batteries containing these hazardous materials should be marked with the NFPA 704 diamond hazard symbols.
- B.3.3 Electrical Hazards.** Under normal operating conditions some battery systems might have electrical hazards that need to be addressed as part of operation and maintenance. Electrical hazards that can occur during normal operating conditions follow:
- (1) *Electrical shock:* ESS with voltages above 50 V (per NFPA 70E limits for electrical shock) can pose hazards to trained workers who might come in contact with live parts during operation and servicing of the systems. It is necessary that appropriate labeling and procedures and protective equipment are utilized by workers when servicing these systems.
- (2) *Arc flash:* ESS that have an incident energy level greater than 1.2 cal/cm² (5 J/cm²) should have the arc flash boundaries calculated, identified through markings, and proper procedures and equipment in place to prevent worker injury from arc flash during normal operation and servicing.
- (3) *Stranded or stored energy hazards:* Energy that can be accumulated and reserved for future use, generally in the form of electricity, is stranded or stored energy. An example of a stranded or stored energy hazard is worker exposure to ESS that are not discharged sufficiently or ESS that are damaged and where the potential exists for electric shock and arc flash issues. For normal operating conditions, sites housing commercial and industrial battery ESS should maintain onsite instructions for isola-

tion of hazardous voltage and energy for maintenance and for discharging batteries for safe replacement and disposal. Residential and smaller commercial systems should have information provided and access to trained technicians to perform these duties to ensure that stranded and stored energy do not represent a hazard under normal operating conditions.

B.3.4 Physical Hazards. Physical hazards can include the following:

- (1) *Burn hazards:* Potential contact with hot surfaces during maintenance that could result in burns if not wearing PPE.
- (2) Parts containing pressurized fluids, including compressed gasses.
- (3) *Parts with kinetic energy:* Parts of the ESS balance of plant components that might contain moving parts that could cause injury if not guarded properly. This might also be an issue for a hybrid system of batteries and flywheels.

B.4 Hazard Considerations Under Emergency/Abnormal Conditions.

B.4.1 Fire Hazards. Fire hazards can include the following:

- (1) Combustible/flammable concentrations due to overheating and venting of flammable gases near sources of ignition can occur during emergency/abnormal conditions. If concentrations of vented gases such as hydrogen are sufficient to create combustible/flammable concentrations in the presence of hot parts, there will be ignition resulting in either a fire or an explosion. All batteries, with the exception of hermetically sealed types such as sodium beta, have means to relieve internal pressure when overheated to prevent explosions of the battery cell from overpressurization.
- (2) There can be fires due to overheating of electrical parts under abnormal conditions such as short circuits.

B.4.2 Chemical Hazards. Examples of chemical hazards are as follows:

- (1) Liquid hazards such as the following:
 - (a) *Corrosive spills:* A liquid with a pH ≤ 2 or ≥ 11.5 is considered corrosive and hazard level 3 and can cause serious or permanent eye injury for someone who comes in direct contact with it per Table B.1, in NFPA 704. With some systems that contain corrosive liquids, there can be the possibility of leaks or spills from the system under emergency/abnormal conditions. Batteries containing corrosive liquids are to be marked health hazard level 3 in the NFPA 704 hazard diamond.
 - (b) *Toxic liquid vapor exposure:* There are different levels of toxicity from liquid vapors that can occur under emergency conditions such as fires and hazardous leaks and spills. There is a range of hazard levels outlined in NFPA 704 as follows:
 - i. *Level 4:* Is lethal under emergency conditions; any liquid whose saturated vapor concentration at 68°F (20°C) is equal to or greater than 10 times its LC₅₀ for acute inhalation toxicity, if its LC₅₀ is less than or equal to 1000 ppm
 - ii. *Level 3:* Can cause serious or permanent injury; any liquid whose saturated vapor concentration at 68°F (20°C) is equal to or

greater than its LC₅₀ for acute inhalation toxicity, if its LC₅₀ is less than or equal to 3000 ppm, and that does not meet the criteria for degree of hazard 4

- iii. *Level 2:* Can cause temporary incapacitation or residual injury under emergency conditions; any liquid whose saturated vapor concentration at 20°C (68°F) is equal to or greater than one-fifth its LC₅₀ for acute inhalation toxicity, if its LC₅₀ is less than or equal to 5000 ppm, and that does not meet the criteria for either degree of hazard 3 or degree of hazard 4
- iv. *Level 1:* Can cause significant irritation under emergency conditions; mists whose LC₅₀ for acute inhalation toxicity is greater than 10 mg/L but less than or equal to 200 mg/L

- (2) *Oxidizers:* The potential exists for oxidizers to be present within the ESS. An oxidizer will increase the intensity of a fire of other materials. Annex G in NFPA 400 provides information on tests to classify an oxidizer material and identifies known oxidizing materials under their classifications. Annex G in NFPA 400 also provides guidance on safety measures to use when there are significant exposed quantities of known oxidizers, which can occur during abnormal conditions of certain ESS technologies that contain them. Batteries containing oxidizers are to be marked in the special hazard section of the NFPA 704 hazard diamond.
- (3) *Solids:* Some battery technologies contain water-reactive material that can react violently when in contact with moisture, including moisture in the air. Although not exposed under normal operating conditions, these materials could be exposed under abnormal conditions. Batteries containing water-reactive substances should be marked as such in the NFPA 704 hazard diamond.
- (4) *Gases — Toxic gases:* Similar to toxic vapors emanating from liquids, there are different levels of hazards associated with toxic gases from level 4 to level 1:
 - (a) *Level 4:* Gases that can be lethal under emergency conditions; gases whose LC₅₀ for acute inhalation toxicity is less than or equal to 1000 parts per million (ppm)
 - (b) *Level 3:* Gases that can cause serious or permanent injury under emergency conditions; gases whose LC₅₀ for acute inhalation toxicity is greater than 1000 ppm but less than or equal to 3000 ppm
 - (c) *Level 2:* Gases that can cause temporary incapacitation or residual injury under emergency conditions; gases whose LC₅₀ for acute inhalation toxicity is greater than 3000 ppm but less than or equal to 5000 ppm
 - (d) *Level 1:* Gases that can cause significant irritation under emergency conditions; gases and vapors whose LC₅₀ for acute inhalation toxicity is greater than 5000 ppm but less than or equal to 10,000 ppm

Note: As outlined in NFPA 704, LC₅₀ for acute toxicity on inhalation is that concentration of vapor, mist, or dust, which, when administered by continuous inhalation to both male and female young adult albino rats for 1 hour, is most likely to cause death within 14 days in one half of the animals tested. The criteria for inhalation toxicity of vapors are based on LC₅₀ data relating to 1-hour exposures.

B.4.3 Electrical Hazards. Examples of electrical hazards are as follows:

- (1) *Electrical shock:* Circuits with voltages above 50 V have the potential for electrical shock hazards, because first responders under emergency conditions would not have the training and protective equipment that trained electrical workers would have under normal servicing and maintenance conditions. Information needs to be available for maintenance staff and first responders on how to address electrical hazards. In addition, under emergency conditions the potential exists for emergency responder exposure to live parts in contact with conductive fluids such as water and live parts exposed as a result of abnormal conditions. Manufacturers/installers of battery energy systems should define standoff distance and type and angle of water spray for first responders. Emergency response guidelines as outlined in 4.3.2.1.3 should address the issue of isolation of hazardous voltages.
- (2) *Shock, arc flash, and arc blast hazards:* First responders are generally not provided with training and proper protection from arc flash, arc blast, and shock hazards, including clothing, gloves, and so forth, so the potential for sufficient energy that will result in a hazardous electrical event occurring during an emergency response exists. Manufacturers should provide emergency response guidance on how to reduce arc flash and blast hazards. See the emergency response guidance in 4.3.2.1.3.
- (3) *Stranded or stored energy hazards:* ESS damaged during an emergency incident can present potential shock, arc flash, arc blast, and reignition hazards. Sites should have access to on-call trained staff to assist in emergency situations to isolate potential hazard energy and, if necessary, to drain energy to prevent potential reignition of some technologies at a later time. For commercial and industrial installations, there needs to be trained personnel available for emergency response on site. For residential and smaller scale commercial systems, on-call trained personnel need to be made available to assist first responders and address discharging of stored energy in batteries for disposal.

Note: UL research into the issue of potential shock to fire fighters from water spray on PV fires indicated that the electric shock hazard due to application of water is dependent on voltage, water conductivity, distance, and spray pattern. For example:

- (1) A slight adjustment from a solid stream toward a fog pattern (a 10-degree cone angle) reduced measured current below perception level.
- (2) Salt water should not be used on live electrical equipment.
- (3) A distance of 20 ft (6.1 m) had been determined to reduce potential shock hazard from a 1000 V dc source to a level below 2 mA considered as safe.

B.4.4 Physical Hazards. Examples of physical hazards are as follows:

- (1) Hazardous pressures can develop due to overheating of equipment and devices that do not have pressure relief means (for some chemistries such as flow batteries and so forth).
- (2) Potential hot parts.
- (3) Exposed parts with hazardous kinetic energy sufficient to cause bodily harm for persons coming in contact with

them, such as exposed fan blades, and so forth, under abnormal conditions.

B.5 Commercially Available Battery Technologies.

B.5.1 Flow Batteries — General Description. A flow battery is an energy storage component similar to a fuel cell that stores its active materials in the form of one or more electrolytes external to the reactor interface. When in use, the electrolytes are transferred between reactor and storage tanks. Two commercially available flow battery technologies with two active electrolytes are zinc bromine and vanadium redox. Zinc bromine flow batteries have zinc at the negative electrode and bromide at the positive electrode with an aqueous solution containing zinc bromide and other compounds contained in reservoirs. During charging, energy is stored as zinc metal within the cell and polybromide in the cathode reservoir. During discharge, the zinc is oxidized to zinc oxide and the bromine is reduced to bromide. Vanadium redox flow batteries contain vanadium salts in various stages of oxidation in a sulfuric acid electrolyte. Charging and discharging the battery changes the oxidation state of the vanadium in the electrolyte solutions. Another commercially available flow battery technology with one active electrolyte containing metal particles is the zinc air flow battery. During charging, zinc particles are generated from a zincate solution in a chemical reaction (i.e., oxygen is off-gassed from the reaction), and then transported to a storage tank in a KOH solution as a charged electrolyte. During discharge the electrolyte is pumped through the reactor interface (i.e., flow battery stack) where the zinc particles combine again with oxygen from the surrounding air to form zincate. The zincate solution can then be recharged for another cycle.

B.5.1.1 Vanadium Redox Flow Batteries. Hazard considerations for vanadium redox flow batteries under normal operating conditions are as follows:

- (1) *Fire hazards:* Not applicable.
- (2) *Chemical hazards:* They contain corrosive liquid that might present a safety concern under normal conditions if there is a need to handle/replenish the electrolyte as part of maintenance.
- (3) *Electrical hazards:* There are electrical hazards associated with routine maintenance of these batteries if they have hazardous voltage and energy levels.
- (4) *Stranded or stored energy hazards:* Not applicable.
- (5) *Physical hazards:* Not applicable.

Hazard considerations for vanadium redox flow batteries under emergency/abnormal conditions are as follows:

- (1) *Fire hazards:* Corrosive liquids can boil off to create gases that are flammable (e.g., hydrogen). There can also be the problems with the balance of plant components overheating and creating the potential for fire hazards under abnormal conditions.
- (2) *Chemical hazards:* There are large amounts of corrosives.
- (3) *Electrical hazards:* Electrical hazards might be present under abnormal conditions if the system is at hazardous voltage and energy levels.
- (4) *Stranded or stored energy hazards:* Not applicable.
- (5) *Physical hazards:* Depending on the design of the system, the potential exists for physical hazards under abnormal conditions if accessible parts are overheating, if there is insufficient pressure relief when the system is overheating and gas is generated, or if there is exposure to moving

hazardous parts such as fans or exposed pump parts where guards might be missing.

B.5.1.2 Zinc Bromine (ZnBr) Flow Batteries. Hazard considerations for ZnBr flow batteries under normal operating conditions are as follows:

- (1) *Fire hazards:* Not applicable.
- (2) *Chemical hazards:* These batteries contain zinc bromide electrolyte, which is corrosive (acid) and toxic with a hazardous classification level of 3 per NFPA 704. The electrolyte should be reliably sealed in the system, so this should only be an issue for normal operating conditions if there is a need to add electrolyte as part of maintenance or installation.
- (3) *Electrical hazards:* There are electrical hazards associated with routine maintenance of these batteries if they are at hazardous voltage and energy levels.
- (4) *Stranded or stored energy hazards:* Not applicable.
- (5) *Physical hazards:* Not applicable.

Hazard considerations for ZnBr flow batteries under emergency/abnormal conditions are as follows:

- (1) *Fire hazards:* If there is overheating of the system due to abnormal conditions, there can be off-gassing of flammable gasses that can present a fire hazard if they are near an ignition source. There can also be problems with the balance of plant components overheating and creating potential for fire hazards under abnormal conditions.
- (2) *Chemical hazards:* These batteries contain zinc bromide electrolyte, which is corrosive (acid) and toxic with a hazardous classification level of 3 per NFPA 704. Under abnormal conditions, care should be taken where there might be spills of the electrolyte.
- (3) *Electrical hazards:* Electrical hazards might be present under abnormal conditions if the system is at hazardous voltage and energy levels.
- (4) *Stranded or stored energy hazards:* Not applicable.
- (5) *Physical hazards:* Depending on the design of the system, the potential exists for physical hazards under abnormal conditions if accessible parts are overheating, if there is insufficient pressure relief when the system is overheating and gas is generated, or if there is exposure to moving hazards parts such as fans or exposed pump parts where guards may be missing.

NB.5.1.3 Zinc Air Flow Batteries. Hazard considerations for zinc air flow batteries under normal operating conditions are as follows:

- (1) *Fire hazards:* There is the potential for concentrations of hydrogen from the charged electrolyte if the area where the electrolyte tank(s) are located is not properly ventilated. However, this should be taken care of if the installation complies with the codes.
- (2) *Chemical hazards:* They contain corrosive liquid that might present a safety concern under normal conditions if there is a need to handle/replenish the electrolyte as part of maintenance.
- (3) *Electrical hazards:* There are electrical hazards associated with routine maintenance of these batteries if they have hazardous voltage and energy levels. Technicians should follow accepted maintenance and installation procedures when working on flow batteries.
- (4) *Stranded or stored energy hazards:* Not applicable.
- (5) *Physical hazards:* Not applicable.

Hazard considerations for zinc air flow batteries under emergency/abnormal conditions are as follows:

- (1) *Fire hazards:* In the presence of electrolyte heating due to an abnormal condition occurring internally to the system or from an external source, there is the potential for concentrations of hydrogen from the charged electrolyte if the area where the electrolyte tank(s) are located is not properly ventilated. With continued heating, the water will evaporate and any hydrogen production will diminish.
- (2) *Chemical hazards:* There are large amounts of corrosives that can create a hazard if the containment fails.
- (3) *Electrical hazards:* Electrical hazards might be present under abnormal conditions if the system is at hazardous voltage and energy levels.
- (4) *Stranded or stored energy hazards:* Not applicable.
- (5) *Physical hazards:* Depending on the design of the system, the potential exists for physical hazards under abnormal conditions if accessible parts are overheating, if there is insufficient pressure relief when the system is overheating and gas is generated, or if there is exposure to moving hazardous parts such as fans or exposed pump parts where guards might be missing.

B.5.2 Lead-Acid Batteries — General Description. Lead-acid batteries have lead dioxide as the active material of their positive electrode and metallic lead as the negative electrode with a dilute sulfuric acid solution electrolyte. During discharge, both positive and negative electrodes are converted to lead sulfate. The two basic categories of lead-acid batteries are as follows:

- (1) Vented lead-acid batteries, also called *wet cell* or *flooded* lead-acid batteries
- (2) Valve-regulated lead-acid (VRLA) batteries, sometimes referred to as *starved electrolyte* or *maintenance-free* batteries

Vented lead-acid batteries typically require periodic water additions, and the contents of the battery are open to the atmosphere through a vent/flame arrester assembly. VRLA batteries are generally sealed to the atmosphere and contain a valve that can open when pressure builds up in the battery and then closes again. The electrolyte in VRLA batteries is immobilized either through use of a gel electrolyte or through absorption of the electrolyte in a porous AGM separator.

B.5.2.1 Vented Lead-Acid (VLA) Batteries. Hazard considerations for vented lead-acid batteries under normal operating conditions are as follows:

- (1) *Fire hazards:* There is the potential for concentrations of hydrogen from vented lead-acid batteries if the area where the batteries are located is not properly ventilated. However, this should be taken care of if the installation complies with the codes.
- (2) *Chemical hazards:* There is the potential for contact with the sulfuric acid electrolyte but this is only a risk when workers are handling electrolyte. Workers handling electrolyte need to use proper PPE. These systems should be provided with spill control and neutralization per codes.
- (3) *Electrical hazards:* There are electrical hazards associated with routine maintenance of these batteries if they are at hazardous voltage and energy levels. Technicians should follow accepted maintenance and installation procedures (for example, see NFPA 70B, IEEE 450, and IEEE 484) when working on VLA batteries.
- (4) *Stranded or stored energy hazards:* There can be the potential for stranded or stored energy hazards during mainte-

nance. Technicians should follow accepted maintenance and installation procedures when working on VLA batteries.

- (5) *Physical hazards:* There are lifting hazards that are only an issue during installation, replacement, or removal.

Hazard considerations for vented lead-acid batteries under emergency/abnormal conditions are as follows:

- (1) *Fire hazards:* There is the potential for concentrations of hydrogen from vented lead-acid batteries due to overheating from abnormal conditions if the area where the batteries are located is not properly ventilated. Another area that can create problems during abnormal conditions is the potential for shorting of high-current circuits.
- (2) *Chemical hazards:* There is the potential for contact with the corrosive sulfuric acid electrolyte during abnormal conditions should acids leak. First responders, in emergency situations, need to be aware of potential acid spills that can occur and use appropriate caution around these batteries.
- (3) *Electrical hazards:* Electrical hazards might be present under abnormal conditions if the system is at hazardous voltage and energy levels.
- (4) *Stranded or stored energy hazards:* There can be the potential for stored or stranded energy hazards if batteries are subject to abnormal conditions. Technicians should follow accepted procedures when working on these batteries where these batteries are subjected to abnormal conditions.
- (5) *Physical hazards:* The potential exists for overheating.

▲ B.5.2.2 Valve-Regulated Lead-Acid (VRLA) Batteries. Hazard considerations for VRLA batteries under normal operating conditions are as follows:

- (1) *Fire hazards:* There should be no combustible gas generation under normal operating conditions if batteries are operated as intended to prevent overheating and thermal runaway conditions.
- (2) *Chemical hazards:* These batteries are starved electrolyte types, so there should be no issue with exposure to corrosive electrolyte under normal operating conditions.
- (3) *Electrical hazards:* There are electrical hazards associated with routine maintenance of these batteries if they are at hazardous voltage and energy levels. Technicians should follow accepted maintenance and installation procedures (for example, see NFPA 70B, IEEE 1187, and IEEE 1188) when working on these batteries.
- (4) *Stranded or stored energy hazards:* There can be the potential for stranded or stored energy hazards during maintenance. Technicians should follow accepted maintenance and installation procedures when working on these batteries.
- (5) *Physical hazards:* There are lifting hazards with large VRLA batteries due to the weight of the battery that are only an issue during installation, replacement, or removal.

Hazard considerations for VRLA batteries under emergency/abnormal conditions are as follows:

- (1) *Fire hazards:* There is the potential for off-gassing of hydrogen under abnormal conditions when batteries overheat. This can present a potential fire hazard due to combustible concentrations if there is no ventilation. VRLA batteries release much less hydrogen than VLA batteries. As a result, the release of hydrogen is not likely to build up to LFL levels assuming standard air change rates per the

building code occupancy classification. There can be the potential for thermal runaway if the batteries are not maintained within appropriate operating parameters or regular system checks and maintenance are neglected. Also, there can be fire hazards due to short-circuiting abnormal conditions.

- (2) *Chemical hazards:* Although these batteries contain corrosive electrolyte, they do not have as much free electrolyte that could result in spill hazards similar to vented types. There might be some bubbling of electrolyte or potential for some leakage under abnormal conditions if battery cases crack or leak.
- (3) *Electrical hazards:* Electrical hazards might be present under abnormal conditions if the system is at hazardous voltage and energy levels. Technicians should follow accepted procedures when working on these batteries under normal conditions.
- (4) *Stranded or stored energy hazards:* There can be the potential for stranded or stored energy hazards if the batteries are subject to abnormal conditions. Technicians should follow accepted procedures when working on these batteries under normal conditions.
- (5) *Physical hazards:* The potential exists for overheating.

▲ B.5.3 Lithium Ion (Li-ion) Batteries — General Description.

The term *lithium-ion battery* refers to a battery where the negative electrode (anode) and positive electrode (cathode) materials serve as a host for the lithium ion (Li⁺). Lithium ions move from the anode to the cathode during discharge and are intercalated into (i.e., inserted into voids in the crystallographic structure of) the cathode. The ions reverse direction during charging. Since lithium ions are intercalated into host materials during charge or discharge, there is no free lithium metal within a lithium-ion cell and thus, even if a cell does ignite due to external flame impingement or an internal fault, metal fire suppression techniques are not appropriate for controlling the lithium-ion fire. *Lithium ion* is a generic term covering a number of different technologies, which can be broken down into the following three main groups that are currently commercially available:

- (1) Lithium metal oxide cathodes with a carbon anode [e.g., nickel cobalt aluminate (NCA) and nickel manganese cobaltate (NMC)]
- (2) Lithium phosphate cathode with a carbon anode [e.g., lithium iron phosphate (LFP)]
- (3) Lithium metal oxide cathode with a titanium oxide anode [e.g., lithium titanate (LTO)]

N B.5.3.1 Lithium Nickel Cobalt Aluminum (NCA) Oxide. NCA (LiNiCoAlO₂ cathode) has a nominal voltage of 3.6 V per cell, and generally a lower temperature to thermal runaway in comparison to other lithium-ion chemistries. Hazard considerations for NCA batteries under normal operating conditions are as follows:

- (1) *Fire hazards:* There can be the potential for fire hazards if there are latent defects within the cells or design issues with the controls that prevent thermal runaway of the cells. Systems need to be evaluated for their ability to prevent propagation due to these defects.
- (2) *Chemical hazards:* Not applicable.
- (3) *Electrical hazards:* There are electrical hazards associated with routine maintenance of these batteries if they are at hazardous voltage and energy levels. Technicians should follow accepted maintenance and installation procedures when working on these batteries.

- (4) *Stranded or stored energy hazards:* There can be the potential for stranded or stored energy hazards during maintenance if the batteries cannot be isolated for maintenance or replacement. Technicians should follow accepted maintenance and installation procedures when working on these batteries.
- (5) *Physical hazards:* Not applicable.

Hazard considerations for NCA batteries under emergency/abnormal conditions are as follows:

- (1) *Fire hazards:* There can be the potential for thermal runaway if the batteries are not maintained within appropriate operating parameters as a result of abnormal conditions. Also, there might be fire hazards due to short-circuiting abnormal conditions.
- (2) *Chemical hazards:* There can be the potential for off-gassing of hazardous vapors under abnormal conditions depending on the size of the cells and the level of failure.
- (3) *Electrical hazards:* Electrical hazards might be present under abnormal conditions if the system is at hazardous voltage and energy levels.
- (4) *Stranded or stored energy hazards:* There can be the potential for stranded energy hazards if the batteries are exposed to abnormal conditions. Damaged batteries might contain stored energy that can be a hazard during disposal if care is not taken. Technicians should follow accepted procedures when working on these batteries where these batteries are subjected to abnormal conditions.
- (5) *Physical hazards:* Depending on the design of the system, the potential exists for physical hazards under abnormal conditions if accessible parts are overheating or if there is exposure to moving hazardous parts, such as fans where guards might be missing

N B.5.3.2 Lithium Nickel Manganese Cobalt (NMC) Oxide.

NMC (LiNiMnCoO₂ cathode) has a nominal voltage of 3.6–3.7 V per cell and is generally a lower temperature to thermal runaway in comparison to other metal-oxide-type lithium-ion chemistries. Hazard considerations for NMC batteries under normal operating conditions are as follows:

- (1) *Fire hazards:* There can be the potential for fire hazards if there are latent defects within the cells or design issues with the controls that prevent thermal runaway of the cells. Systems need to be evaluated for their ability to prevent propagation due to these defects.
- (2) *Chemical hazards:* Not applicable.
- (3) *Electrical hazards:* There are electrical hazards associated with routine maintenance of these batteries if they are at hazardous voltage and energy levels. Technicians should follow accepted maintenance and installation procedures when working on these batteries.
- (4) *Stranded or stored energy hazards:* There can be the potential for stranded or stored energy hazards during maintenance if the batteries cannot be isolated for maintenance or replacement.
- (5) *Physical hazards:* Not applicable.

Hazard considerations for NMC batteries under emergency/abnormal conditions are as follows:

- (1) *Fire hazards:* There can be the potential for thermal runaway if the batteries are not maintained within appropriate operating parameters as a result of abnormal conditions. Also, there might be fire hazards due to short-circuiting abnormal conditions.

- (2) *Chemical hazards:* There can be the potential for off-gassing of hazardous vapors under abnormal conditions depending on the size of the cells and the level of failure.
- (3) *Electrical hazards:* Electrical hazards might be present under abnormal conditions if the system is at hazardous voltage and energy levels.
- (4) *Stranded or stored energy hazards:* There can be the potential for stranded energy hazards if the batteries are exposed to abnormal conditions. Damaged batteries might contain stored energy that can be a hazard during disposal if care is not taken. Technicians should follow accepted procedures when working on these batteries where these batteries are subjected to abnormal conditions.
- (5) *Physical hazards:* Depending on the design of the system, the potential exists for physical hazards under abnormal conditions if accessible parts are overheating or if there is exposure to moving hazardous parts, such as fans where guards might be missing.

N B.5.3.3 Lithium Iron Phosphate (LFP). LFP (LiFePO₄ cathode) has a nominal voltage of 3.2 V per cell, and generally a higher temperature to thermal runaway in comparison to other lithium-ion chemistries.

Hazard considerations for LFP batteries under normal operating conditions are as follows:

- (1) *Fire hazards:* There can be the potential for fire hazards if there are latent defects within the cells or design issues with the controls that prevent thermal runaway of the cells. Systems need to be evaluated for their ability to prevent propagation due to these defects.
- (2) *Chemical hazards:* Not applicable.
- (3) *Electrical hazards:* There are electrical hazards associated with routine maintenance of these batteries if they are at hazardous voltage and energy levels. Technicians should follow accepted maintenance and installation procedures when working on these batteries.
- (4) *Stranded or stored energy hazards:* There can be the potential for stranded or stored energy hazards during maintenance if the batteries cannot be isolated for maintenance or replacement. Technicians should follow accepted maintenance and installation procedures when working on these batteries.
- (5) *Physical hazards:* Not applicable.

Hazard considerations for LFP batteries under emergency/abnormal conditions are as follows:

- (1) *Fire hazards:* There can be the potential for thermal runaway if the batteries are not maintained within appropriate operating parameters as a result of abnormal conditions. Also, there might be fire hazards due to short-circuiting abnormal conditions.
- (2) *Chemical hazards:* There can be the potential for off-gassing of hazardous vapors under abnormal conditions depending on the size of the cells and the level of failure.
- (3) *Electrical hazards:* Electrical hazards might be present under abnormal conditions if the system is at hazardous voltage and energy levels. Technicians should follow accepted maintenance and installation procedures when working on these batteries.
- (4) *Stranded or stored energy hazards:* There can be the potential for stranded energy hazards if the batteries are exposed to abnormal conditions. Damaged batteries might contain stored energy that can be a hazard during

disposal if care is not taken. Technicians should follow accepted procedures when working on these batteries where these batteries are subjected to abnormal conditions.

- (5) *Physical hazards:* Depending on the design of the system, the potential exists for physical hazards under abnormal conditions if accessible parts are overheating or if there is exposure to moving hazardous parts, such as fans where guards might be missing.

NB.5.3.4 LTO [(Li₂TiO₃) anode with either NMC or NMO/nickel manganese oxide cathode] has a nominal voltage of 2.4 V per cell, and generally a higher temperature to thermal runaway in comparison to other lithium-ion chemistries.

Hazard considerations for LTO batteries under normal operating conditions are as follows:

- (1) *Fire hazards:* There can be the potential for fire hazards if there are latent defects within the cells or design issues with the controls that prevent thermal runaway of the cells. Systems need to be evaluated for their ability to prevent propagation due to these defects.
- (2) *Chemical hazards:* Not applicable.
- (3) *Electrical hazards:* There are electrical hazards associated with routine maintenance of these batteries if they are at hazardous voltage and energy levels. Technicians should follow accepted maintenance and installation procedures when working on these batteries.
- (4) *Stranded or stored energy hazards:* There can be the potential for stranded or stored energy hazards during maintenance if the batteries cannot be isolated for maintenance or replacement. Technicians should follow accepted maintenance and installation procedures when working on these batteries.
- (5) *Physical hazards:* Not applicable.

Hazard considerations for LTO batteries under emergency/abnormal conditions are as follows:

- (1) *Fire hazards:* There can be the potential for thermal runaway if the batteries are not maintained within appropriate operating parameters as a result of abnormal conditions. Also, there might be fire hazards due to short-circuiting abnormal conditions.
- (2) *Chemical hazards:* There can be the potential for off-gassing of hazardous vapors under abnormal conditions depending on the size of the cells and the level of failure.
- (3) *Electrical hazards:* Electrical hazards might be present under abnormal conditions if the system is at hazardous voltage and energy levels.
- (4) *Stranded or stored energy hazards:* There can be the potential for stranded energy hazards if the batteries are exposed to abnormal conditions. Damaged batteries might contain stored energy that can be a hazard during disposal if care is not taken. Technicians should follow accepted procedures when working on these batteries where these batteries are subjected to abnormal conditions.
- (5) *Physical hazards:* Depending on the design of the system, the potential exists for physical hazards under abnormal conditions if accessible parts are overheating or if there is exposure to moving hazardous parts, such as fans where guards might be missing.

B.5.4 Lithium Metal, Solid State Batteries — General Description. Lithium metal batteries employing liquid electrolytes

have been developed for commercial use but have had safety and performance problems in the field. These batteries have not been developed at this time for stationary battery energy storage. Commercially available lithium metal batteries utilized for ESS do not employ liquid electrolytes. The current lithium metal technologies use solid polymer electrolytes, a lithium metal negative electrode and a metal oxide cathode such as vanadium oxide combined with lithium salt and polymer to form a plastic composite. The SPE-type lithium metal batteries must be heated to about 140°F to 176°F (60°C to 80°C) in order to be activated.

Hazard considerations for lithium metal batteries under normal operating conditions are as follows:

- (1) *Fire hazards:* There can be the potential for fire hazards if there are defects within the cells or design issues with the controls that prevent thermal runaway of the cells. Systems need to be evaluated for their ability to prevent propagation due to these defects.
- (2) *Chemical hazards:* Not applicable.
- (3) *Electrical hazards:* There are electrical hazards associated with routine maintenance of these batteries if they are at hazardous voltage and energy levels.
- (4) *Stranded or stored energy hazards:* There can be the potential for stranded or stored energy hazards during maintenance if the batteries cannot be isolated for maintenance or replacement.
- (5) *Physical hazards:* Not applicable.

Hazard considerations for lithium metal batteries under emergency/abnormal conditions are as follows:

- (1) *Fire hazards:* There can be the potential for thermal runaway if the batteries are not maintained at appropriate operating parameters as a result of abnormal conditions and if not evaluated for ability to prevent propagation due to latent defects. Also there might be fire hazards due to short-circuiting abnormal conditions.
- (2) *Chemical hazards:* The potential exists for exposure of water-reactive lithium metal.
- (3) *Electrical hazards:* Electrical hazards might be present under abnormal conditions if the system is at hazardous voltage and energy levels.
- (4) *Stranded or stored energy hazards:* There can be the potential for stranded or stored energy hazards if the batteries are exposed to abnormal conditions where they might still contain hazardous levels of energy. Damaged batteries might contain stored energy that can be a hazard during disposal if care is not taken.
- (5) *Physical hazards:* Depending on the design of the system, the potential exists for physical hazards under abnormal conditions if accessible parts are overheating or if there is exposure to moving hazardous parts such as fans where guards might be missing.

B.5.5 Nickel Batteries — General Description. Nickel batteries for stationary applications are divided into two main technologies: nickel-cadmium (Ni-Cd) and nickel-metal hydride (Ni-MH). There is also a third category that has become commercialized, nickel-zinc (Ni-Zn), which is very similar to Ni-Cd batteries. Nickel-cadmium batteries have nickel hydroxide active material for the positive electrode and cadmium for the negative electrode with potassium hydroxide solution for the electrolyte. The nickel-cadmium batteries for stationary applications can be vented pocket plate or vented sintered-plate batteries that are designed of multiple cells in a monobloc

battery similar to a vented lead-acid battery. They also have vents for maintenance of the electrolyte. Nickel-cadmium batteries can also be sealed types, such as a fiber nickel-cadmium battery that is sealed in and provided with a pressure relief valve similar to a VRLA battery. Nickel-zinc batteries are similar to Ni-Cd batteries except the negative electrode is zinc. Nickel-metal hydride batteries have nickel hydroxide active material for the positive electrode, a metal hydride alloy for the negative electrode, and a solution of potassium hydroxide as the electrolyte. Nickel-metal hydride batteries are sealed with either a single-cell design or a monobloc design with multiple internal cells and are provided with an enclosable valve for relieving pressure similar to a VRLA battery.

B.5.5.1 Nickel-Cadmium (Ni-Cd) and Nickel-Zinc (Ni-Zn) Batteries. Hazard considerations for Ni-Cd and Ni-Zn batteries under normal operating conditions are as follows:

- (1) *Fire hazards:* There is the potential for concentrations of hydrogen from vented Ni-Cd and Ni-Zn batteries if the area where the batteries are located is not properly ventilated. However, this should be taken care of if the installation complies with the codes.
- (2) *Chemical hazards:* There is the potential for contact with the corrosive/caustic potassium hydroxide electrolyte but this is only a risk when workers are handling electrolyte. Workers handling electrolyte need to use proper PPE. These systems should be provided with spill control and neutralization per codes.
- (3) *Electrical hazards:* There are electrical hazards associated with routine maintenance of these batteries if they are at hazardous voltage and energy levels.
- (4) *Stranded or stored energy hazards:* There can be the potential for stranded or stored energy hazards during maintenance if the batteries cannot be isolated for maintenance or replacement.
- (5) *Physical hazards:* There are lifting hazards due to the weight of the battery that are only an issue during installation replacement or removal.

Hazard considerations for Ni-Cd and Ni-Zn batteries under emergency/abnormal conditions are as follows:

- (1) *Fire hazards:* There is the potential for concentrations of hydrogen from vented Ni-Cd and Ni-Zn batteries due to overheating from abnormal conditions if the area where the batteries are located is not properly ventilated. Another area that might create problems during abnormal conditions would be the potential for shorting of high-current circuits.
- (2) *Chemical hazards:* There is the potential for contact with the corrosive/caustic potassium hydroxide electrolyte during abnormal conditions should electrolyte leak. First responders, in an emergency situation, need to be aware of potential caustic spills that can occur and take appropriate caution around these batteries. Ni-Cd batteries contain cadmium, which is toxic and a hazardous waste. Although not exposed under normal conditions, there might be potential for cadmium in vapors of burning batteries during abnormal conditions.
- (3) *Electrical hazards:* Electrical hazards might be present under abnormal conditions if the system is at hazardous voltage and energy levels.
- (4) *Stranded or stored energy hazards:* There can be the potential for stranded or stored energy hazards if the batteries are exposed to abnormal conditions where they could still contain hazardous levels of energy. Damaged batteries

might contain stored energy that can be a hazard during disposal if care is not taken.

- (5) *Physical hazards:* The potential exists for overheating.

B.5.5.2 Nickel-Metal Hydride (Ni-MH) Batteries. Hazard considerations for Ni-MH batteries under normal operating conditions are as follows:

- (1) *Fire hazards:* There should be no combustible gas generation under normal operating conditions, if batteries are operated as intended to prevent overheating and thermal runaway conditions.
- (2) *Chemical hazards:* These batteries are starved electrolyte types, so there should be no issue with exposure to corrosive electrolyte under normal operating conditions.
- (3) *Electrical hazards:* There are electrical hazards associated with routine maintenance of these batteries if they are at hazardous voltage and energy levels.
- (4) *Stranded or stored energy hazards:* There can be the potential for stranded or stored energy hazards during maintenance if the batteries cannot be isolated for maintenance or replacement.
- (5) *Physical hazards:* Not applicable.

Hazard considerations for Ni-MH batteries under emergency/abnormal conditions are as follows:

- (1) *Fire hazards:* There is the potential for off-gassing of hydrogen under abnormal conditions when batteries overheat. This can present a potential fire hazard due to combustible concentrations. There can be the potential for thermal runaway if the batteries are not maintained at appropriate operating parameters. Also, there could be fire hazards due to short-circuiting abnormal conditions.
- (2) *Chemical hazards:* Although these batteries contain corrosive electrolyte, they do not have as much free electrolyte that could result in spill hazards similar to vented types. There might be some bubbling of electrolyte or potential for some leakage under abnormal conditions if battery cases crack or leak. Burning Ni-MH batteries can release toxic vapors, including cobalt oxide fumes, nickel oxide fumes, and so forth.
- (3) *Electrical hazards:* Electrical hazards can be present under abnormal conditions if the system is at hazardous voltage and energy levels.
- (4) *Stranded or stored energy hazards:* There can be the potential for stranded or stored energy hazards if the batteries are exposed to abnormal conditions where they might still contain hazardous levels of energy. Damaged batteries might contain stored energy that can be a hazard during disposal if care is not taken.
- (5) *Physical hazards:* Depending on the design of the system, the potential exists for physical hazards under abnormal conditions if accessible parts are overheating or if there is exposure to moving hazardous parts such as fans where guards might be missing.

B.5.6 Sodium Batteries, Aqueous — General Description. Aqueous sodium batteries, which are also referred to as *sodium ion batteries* or *saltwater batteries*, consist of a manganese oxide positive electrode, a carbon titanium phosphate composite anode, and a saltwater solution electrolyte, and sodium ions intercalate between the positive and negative electrode during the charge and discharge operation. These sodium batteries operate at ambient temperatures with an optimal range of 23°F to 104°F (–5°C to 40°C).

Hazard considerations for aqueous sodium batteries under normal operating conditions are as follows:

- (1) *Fire hazards:* There should be no combustible gas generation under normal operating conditions if batteries are operated as intended to prevent overheating and thermal runaway conditions.
- (2) *Chemical hazards:* Not applicable.
- (3) *Electrical hazards:* There are electrical hazards associated with routine maintenance of these batteries if they are at hazardous voltage and energy levels.
- (4) *Stranded or stored energy hazards:* The potential exists for stranded or stored energy hazards during maintenance if the batteries cannot be isolated for maintenance.
- (5) *Physical hazards:* Lifting hazards due to the weight of the battery that are only applicable during installation, replacement, or removal.

Hazard considerations for aqueous sodium batteries under emergency/abnormal conditions are as follows:

- (1) *Fire hazards:* These systems have aqueous electrolytes, so the potential exists for off-gassing of hydrogen under abnormal conditions. The potential might also exist for fire hazards for high-energy systems that are subject to short-circuit or other abnormal conditions.
- (2) *Chemical hazards:* Not applicable.
- (3) *Electrical hazards:* Electrical hazards might be present under abnormal conditions if the system is at hazardous voltage and energy levels.
- (4) *Stranded or stored energy hazards:* The potential exists for stranded or stored energy hazards if the batteries are exposed to abnormal conditions where they might still contain hazardous levels of energy.
- (5) *Physical hazards:* The potential for overheating exists.

N B.5.7 High-Temperature Batteries—General Description.

High-temperature batteries are molten-salt-type batteries that are inactive at ambient temperatures and require elevated temperatures [i.e., from 500°F to 932°F (260°C to 500°C) and higher] to operate depending upon the chemistry. Commercially available chemistry types include the high-temperature sodium batteries that have a ceramic beta-alumina electrolyte and a molten battery technology using antimony as a cathode and calcium as the anode with a molten salt electrolyte. These high-temperature batteries are hermetically sealed and become operational at temperatures high enough for the internal materials serving as the anode and cathode to liquify, allowing for the chemical reactions to take place for charging and discharging.

B.5.7.1 Sodium Batteries, High-Temperature — General Description. High-temperature sodium batteries, sometimes referred to as *sodium beta batteries* or *molten salt batteries*, are hermetically sealed batteries with metallic sodium as the negative electrode and a ceramic beta-alumina as the electrolyte. These batteries operate at high temperatures of 500°F to 698°F (260°C to 370°C) so that the active materials are in a molten state and to ensure ionic conductivity. There are two types of commercially available high-temperature sodium batteries: sodium sulfur and sodium nickel chloride. Sodium sulfur batteries consist of a sodium negative electrode, a beta-alumina electrolyte, and a sulfur positive electrode with an operating temperature within a temperature range of 590°F to 698°F (310°C to 370°C). Sodium nickel chloride batteries consist of a sodium negative electrode, a beta-alumina as the electrolyte, and a positive electrode that could consist of nickel, nickel

chloride, or sodium chloride with an operating temperature range of 500°F to 662°F (260°C to 350°C).

B.5.7.1.1 Sodium Sulfur (Na-S) Batteries. Hazard considerations for Na-S batteries under normal operating conditions are as follows:

- (1) *Fire hazards:* The potential exists for fire hazards if there are latent defects within the cells or design issues with the controls that prevent thermal runaway of the cells. Systems need to be evaluated for their ability to prevent propagation due to these defects.
- (2) *Chemical hazards:* Not applicable. The batteries contain water-reactive sodium, but the systems are hermetically sealed.
- (3) *Electrical hazards:* There are electrical hazards associated with routine maintenance of these batteries if they are at hazardous voltage and energy levels.
- (4) *Stranded or stored energy hazards:* The potential exists for stranded or stored energy hazards during maintenance if the batteries cannot be isolated for maintenance.
- (5) *Physical hazards:* There should be no hazards associated with these batteries if the designs have sufficient insulation to prevent exposure to hot surfaces, because these batteries run at very hot temperatures under normal operating conditions.

Hazard considerations for Na-S batteries under emergency/abnormal conditions are as follows:

- (1) *Fire hazards:* These systems might be subject to thermal runaway due to defects within the cells and protection scheme. Large energy systems can result in fires if there are abnormal conditions such as short-circuiting.
- (2) *Chemical hazards:* The potential exists for exposure to hazardous water-reactive materials if the hermetic seals are broken and sodium is exposed to the atmosphere. PPE is required to address exposure during abnormal conditions.
- (3) *Electrical hazards:* Electrical hazards might be present under abnormal conditions if the system is at hazardous voltage and energy levels.
- (4) *Stranded or stored energy hazards:* The potential exists for stranded or stored energy hazards if the batteries are exposed to abnormal conditions where they might still contain hazardous levels of energy. Technicians should follow accepted procedures when working on these batteries where these batteries are subjected to abnormal conditions.
- (5) *Physical hazards:* Depending on the design of the system, the potential exists for physical hazards under abnormal conditions if accessible parts are overheating.

B.5.7.1.2 Sodium Nickel Chloride Batteries. Hazard considerations for sodium nickel chloride batteries under normal operating conditions are as follows:

- (1) *Fire hazards:* The potential exists for fire hazards if there are latent defects within the cells or design issues with the controls that prevent thermal runaway of the cells. Systems need to be evaluated for their ability to prevent propagation due to these defects.
- (2) *Chemical hazards:* Not applicable. Although sodium is water reactive, the systems are hermetically sealed and will not release any material during normal operation.
- (3) *Electrical hazards:* There are electrical hazards associated with routine maintenance of these batteries if they are at hazardous voltage and energy levels. Technicians should

follow accepted maintenance and installation procedures when working on these batteries.

- (4) *Stranded or stored energy hazards:* The potential exists for stranded or stored energy hazards during maintenance if the batteries cannot be isolated for maintenance. Technicians should follow accepted maintenance and installation procedures when working on these batteries.

Availability of stored energy is based on internal temperature. Once internal temperature drops below the minimum operating temperature, typically 500°F (260°C), any energy stored or stranded becomes electrically unavailable external to the module. The battery will then slowly release its heat energy at approximately the 100W rate. When the internal temperature drops below the solidification or freezing point of the active materials [approximately 302°F (150°C)], the release of any stored or stranded electrical energy is no longer possible. The electrical energy will not become available again until the heat energy is replaced from an external source.

- (5) *Physical hazards:* There should be no hazards associated with these batteries if the designs have sufficient insulation to prevent exposure to hot surfaces, because these batteries run at high temperatures under normal operating conditions. There might be a lifting hazard due to the weight of the battery, which is only an issue during installation, replacement, or removal.

Hazard considerations for sodium nickel chloride batteries under emergency/abnormal conditions are as follows:

- (1) *Fire hazards:* These systems might be subject to thermal runaway due to defects within the cells and protection scheme. Large energy systems can result in fires if there are abnormal conditions such as external short-circuiting.
- (2) *Chemical hazards:* The potential exists for exposure to hazardous water-reactive materials if the hermetic seals are broken and sodium is exposed to the atmosphere. PPE is required to address exposure during abnormal conditions.
- (3) *Electrical hazards:* Electrical hazards might be present under abnormal conditions if the system is at hazardous voltage and energy levels. Technicians should follow accepted procedures when working on these batteries subjected to abnormal conditions.

In most cases, these hazards will be mitigated because the electrical energy will be isolated from external power terminals during alarm or fault conditions. The battery will then slowly release its heat energy at approximately the 100W rate. When the internal temperature drops below the solidification point (i.e., freezing) of the active materials [approximately 302°F (150°C)], the release of any stored electrical energy is no longer possible.

- (4) *Stranded or stored energy hazards:* The potential exists for stranded or stored energy hazards if the batteries are exposed to abnormal conditions where they could still contain hazardous levels of energy. Technicians should follow accepted procedures when working on these batteries subjected to abnormal conditions.

Availability of stored energy is based on internal temperature. Once internal temperature drops below the minimum internal operating temperature, typically 500°F (260°C), any energy stored or stranded becomes electrically unavailable external to the module. The battery will then slowly release its heat energy at approximately the

100W rate. When the internal temperature drops below the solidification point (i.e., freezing) of the active materials [approximately 302°F (150°C)], the release of any stored or stranded electrical energy is no longer possible. The electrical energy will not become available again until the heat energy is replaced from an external source.

- (5) *Physical hazards:* Depending on the design of the system, the potential exists for physical hazards under abnormal conditions if accessible parts are overheating.

N B.5.7.2 Liquid Metal Battery—General. A liquid metal battery operates at 932°F (500°C) and it comprises a liquid calcium alloy anode, a molten salt electrolyte, and a cathode comprising solid antimony particles. At room temperature, the calcium alloy and the salt electrolyte are solid and the electrolyte is non-conductive, thereby rendering the battery inactive and unable to accept or pass current. Therefore, with solidified components at ambient temperature, the cells do not pose any voltage or electrical hazard, which provides significant safety advantages during system assembly and transportation, or if a deployed system is allowed to cool. Upon heating to 932°F (500°C) the anode and salt liquify, which activates the battery, generating a nominal cell voltage of 0.95 Vdc.

Hazard considerations for liquid metal batteries under normal operating conditions are as follows:

- (1) *Fire hazards:* Due to a high operating temperature, cells are operated inside a thermally insulated container and with nonflammable materials of construction, thereby minimizing potential fire hazards. Other possible failure modes, including overcharging, undercharging, high rate operation, and rupturing the cell container do not create fire hazards.
- (2) *Chemical hazards:* Not applicable. The cells are hermetically sealed.
- (3) *Electrical hazards:* There are electrical hazards associated with routine maintenance of these batteries if they are at hazardous voltage and energy levels while the system is at operating temperature. When cooled, the dc-system voltage drops to zero and is unable to pass or accept current. Technicians should follow accepted maintenance and installation procedures when working on these batteries.
- (4) *Stranded or stored energy hazards:* The potential exists for stranded or stored energy hazards during maintenance if the batteries cannot be isolated for maintenance while the system is at operating temperature. However, when the battery is solidified [below 932°F (500°C)], there is no stranded energy hazard. Technicians should follow accepted maintenance and installation procedures when working on these batteries.
- (5) *Physical hazards:* There should be no physical hazards associated with these batteries if the designs have sufficient insulation to prevent exposure to hot surfaces, because these batteries run at high temperatures under normal operating conditions.

There might be a lifting hazards due to the weight of the battery, which is only an issue during installation, replacement, or removal.

Hazard considerations for liquid metal batteries under emergency/abnormal conditions are as follows:

- (1) *Fire hazards:* The potential exists for a large amount of heat generation if an abnormal event occurs, such as system short-circuiting; however, even if a large amount of

heat is generated, it is not expected to result in fire hazards due to the lack of combustible materials around the cells. The flammability of calcium metal inside the cell is lower than metals used in other high-temperature batteries, such as sodium metal, further reducing the risk of fires compared to other high-temperature battery technologies. Cells tested individually are not at risk of thermal runaway or generating a fire event if breached and exposed to air; additional testing is required at a systems level to confirm that full-scale systems are also not subject to thermal runaway events or fire.

- (2) *Chemical hazards:* The potential exists for exposure to hazardous water-reactive materials if the cell container or seal is broken and the calcium alloy is exposed to the atmosphere. PPE is required to address exposure during abnormal conditions.
- (3) *Electrical hazards:* Electrical hazards might be present under abnormal conditions if the system is at hazardous voltage and energy levels.
- (4) *Stranded or stored energy hazards:* The potential exists for stranded or stored energy hazards if the batteries are exposed to abnormal conditions where they could still contain hazardous levels of energy. Technicians should follow accepted procedures when working on these batteries where these batteries are subjected to abnormal conditions.
- (5) *Physical hazards:* Depending on the design of the system, the potential exists for physical hazards under abnormal conditions if accessible parts are overheating.

▲ B.6 Other Technologies.

N B.6.1 Electrochemical Double-Layer Capacitors — General.

An electrochemical double-layer capacitor (EDLC) is a device that is capable of holding a charge longer than other capacitors due to the special surface technology on the electrodes, which are typically made from carbon. There are no Faradaic (redox) reactions that take place within EDLCs, but charge is stored electrostatically within the layers. The EDLC is not as energy dense as batteries, but have a higher power density when compared with batteries with capacitances in the multiple Farads. EDLCs often contain a liquid electrolyte, which can be flammable (e.g., acetonitrile). Charging and discharging of EDLCs can be done often at higher rates than battery technologies, which makes this technology useful in hybrid applications with batteries and fuel cell systems as a “front end” energy source for initial discharge until the battery or fuel cell systems can respond. It can also absorb high rates of current, which has made them useful for purposes of power absorption or for vehicle regenerative braking.

There are devices falling under the “ultra or supercapacitor” grouping referred to as “pseudo capacitors” where there are Faradaic reactions taking place and “hybrid capacitors” where there are Faradaic reactions taking place on one electrode and charge stored electrostatically typical of most EDLCs on the other electrode.

Hazard considerations for EDLCs under normal operating conditions are as follows:

- (1) *Fire hazards:* EDLCs often contain flammable electrolyte such as acetonitrile and can present a fire hazard if voltages not controlled to specified levels during charging.
- (2) *Chemical hazards:* Not applicable.

- (3) *Electrical hazards:* There are electrical hazards associated with routine maintenance of these EDLCs if they are at hazardous voltage and energy levels. Technicians should follow accepted maintenance and installation procedures when working on these capacitors.
- (4) *Stranded or stored energy hazards:* Although not as energy dense as batteries, there is the potential for some level of stranded energy in these devices. Care should be taken to discharge them prior to handling or disposal. Technicians should follow accepted maintenance and installation procedures when working on these capacitors.
- (5) *Physical hazards:* Not applicable.

Hazard considerations for EDLCs under emergency/abnormal conditions are as follows:

- (1) *Fire hazards:* If overcharged or overheated, there could be the potential for flammable off-gassing that could result in a fire. As these devices are often used in locations where they will sustain high-current discharge or inrush, there is the potential for electrical fires downstream if adequate protection is not provided.
- (2) *Chemical hazards:* There is the potential for off gassing of toxic vapors under abnormal conditions, so protective breathing apparatus should be used around venting capacitors. The electrolyte exposure can present a skin or eye irritant, so care needs to be taken when handling any damaged or vented capacitors.
- (3) *Electrical hazards:* Electrical hazards might be present under abnormal conditions if the system is at hazardous voltage and energy levels.
- (4) *Stranded or stored energy hazards:* Although not as energy dense as batteries, there is the potential for some level of stranded energy in these devices if they are exposed to abnormal conditions. Damaged capacitors might contain stored energy that can be a hazard during disposal if care is not taken. Technicians should follow accepted procedures when working on these capacitors where these capacitors are subjected to abnormal conditions.
- (5) *Physical hazards:* Depending on the design of the system, the potential exists for physical hazards under abnormal conditions if accessible parts are overheating or if there is exposure to moving hazardous parts such as fans where guards might be missing.

N B.6.2 Reserved.

▲ Annex C Firefighting Considerations (Operations)

This annex is not a part of the requirements of this NFPA document but is included for informational purposes only.

▲ C.1 Overview. Annex C provides information that firefighters and emergency responders should know to allow them to effectively respond to events involving energy storage systems (ESS).

C.1.1 Emergency Responder Pre-incident Planning. Emergency planning and training for facility staff and emergency responders is covered in Section 4.3. The fire department should develop a pre-incident plan for responding to fires, explosions, and other emergency conditions associated with the ESS installation, and the pre-incident plan should include the following elements:

- (1) Understanding the procedures included in the facility operation and emergency response plan described

- (2) Identifying the types of ESS technologies present, the potential hazards associated with the systems, and methods for responding to fires and incidents associated with the particular ESS
- (3) Identifying the location of all electrical disconnects in the building and understanding that electrical energy stored in ESS equipment cannot always be removed or isolated
- (4) Understanding the procedures for shutting down and de-energizing or isolating equipment to reduce the risk of fire, electric shock, and personal injury hazards
- (5) Understanding the procedures for dealing with damaged ESS equipment in a post-fire incident, including the following:
 - (a) Recognizing that stranded electrical energy in fire-damaged storage batteries and other ESS has the potential for reignition long after initial extinguishment
 - (b) Contacting personnel qualified to safely remove damaged ESS equipment from the facility (This contact information is included in the facility operation and emergency response plan.)

C.2 General. Battery ESS based on electrochemical technologies represent the majority of ESS being designed and installed. The safe operation of electrochemical ESS is critical especially when installed inside occupied structures. The primary concerns of the fire service with this type of installation would include the implications of overheating via internal or external heat source, thermal runaway, potential deflagration event in enclosed spaces, and the effective operation of fire detection, suppression, and smoke exhaust systems. There are additional concerns to be considered when assessing firefighter responses to electrochemical ESS.

Handover procedures for potentially damaged systems should be developed for fire departments to ensure the timely response of qualified technical representatives to manage safety issues. These procedures would also cover issues such as the removal or recycling of damaged equipment. Another procedural component is the realization that damaged ESS system components could include significant stored or stranded energy with no known method for safe dissipation. Stored or stranded energy could be defined as energy that remains in a battery after the system has been shut down.

C.3 Suppression Systems. Some ESS design validations have included pre-engineered inert or clean agent fire suppression systems for fire protection. These system installations were often approved without validation based on fire and explosion testing in accordance with 9.1.5 by nationally recognized testing laboratories. Evidence-based data is needed to ensure ESS designers specify appropriate fire protection systems based on the material involved and physical design characteristics. Several early research papers from multiple organizations, including NFPA's Fire Protection Research Foundation, and third-party engineering groups have shown that fires involving lithium-ion cells must be cooled to terminate the thermal runaway process. Water is the agent of choice, yet system cabinet design could pose a significant barrier to the efficient application of water while simultaneously allowing the free movement of fire and combustion gases.

C.4 Emergency Response to ESS Incidents. Responses to ESS incidents should take into consideration the range of possible conditions and associated hazards as specified in Annex B. The response should include commonly accepted practices with any

hazmat response, including isolating the area to all personnel, confirming location and type of alarm, performing air monitoring, managing ventilation/exhaust, and suppressing fires.

One of the more challenging types of incidents will be one where no signs of overheating are visible and no information is available via integral displays. This places the responding fire official in the challenging position of determining what is safe or not with very little information. Integrated energy management systems (EMS) are designed to monitor and manage critical safety parameters of the battery such as cell temperature, voltage, and available current. While this data might prove valuable to responders to best understand the current state of the battery, there is no standard for manufacturers to provide a user interface to access the state of these parameters or a method to interface to monitored alarm systems within the building. Responders should attempt to gather any visible information prior to shutting down the system unless there is clear evidence of imminent danger. Additionally, the response of a qualified and trained individual in ESS should be made available in the event of damage to an installed system.

C.4.1 Overheated Batteries. The process of charging/discharging results in heat dissipation from cells. An optimum overall system design should include cascading layers of hardware and software protection, including at the battery cell, module or pod, and rack levels. Should a fault occur and overheating of a cell continues, damage could occur resulting in swelling, off-gassing, fire, or explosion. Proper response to an overheated battery should include the following procedures and steps:

- (1) Isolate area of all nonessential personnel
- (2) Review status of both building and ESS alarm system with available data
- (3) Review status of any fire protection system activation
- (4) Perform air monitoring of all connected spaces
- (5) Identify location of overheated battery
- (6) Isolate affected battery, string, or entire system based on the extent of damage by opening battery disconnect switches, where provided
- (7) Contact person or company responsible for operation and maintenance of system
- (8) Continue temperature monitoring to ensure mitigation of overheating condition

C.4.2 Fires. Fires in electrochemical ESS are often a result of a process called *thermal runaway*. Thermal runaway can simply be defined as the process in which a battery creates heat but cannot dissipate that heat, resulting in dynamic temperature increase. Initial signs of thermal runaway might include pressure increase at the cell level, temperature increase, and off-gassing. As the process continues, additional signs might include vent gas ignition, exploding cells, projectile release, heat propagation, and flame propagation.

As the failure cascades, responders should also be prepared for toxic and potentially explosive gas release. Though fire and explosion testing in accordance with 9.5.3.2 to determine battery burn outcomes, including toxic gas release calculations, remains incomplete, responders should treat them as highly dangerous and use their full suite of PPE and breathing apparatus when responding.

Proper response to electrochemical ESS fires should include the following procedures and steps:

- (1) System isolation and shutdown

- (2) Hazard confinement and exposure protection
- (3) Fire suppression
- (4) Ventilation

C.5 Suppressing Agent Choice Considerations. An in-depth understanding of battery failure and suppressing agent properties is essential to the response strategy. There is anecdotal evidence that a number of suppressants could work to suppress burning batteries. However, some perform better than others. Battery chemistry plays a significant role in suppressant choice as some suppressants will perform well on a single chemistry while others might work well on a suite of battery chemistries. Additionally, some suppressants might be inappropriate for certain battery chemistries, and their release could create a more dangerous situation.

When choosing a suppression system, the following should be considered:

- (1) Cooling effect
- (2) Availability
- (3) Portability
- (4) Conductivity
- (5) Available testing data
- (6) Cascading protections

C.5.1 Lithium-Ion (Li-ion) Batteries. Water is considered the preferred agent for suppressing lithium-ion battery fires. Water has superior cooling capacity, is plentiful (in many areas), and is easy to transport to the seat of the fire. While water might be the agent of choice, the module/cabinet configuration could make penetration of water difficult for cooling the area of origin, but might still be effective for containment. Water spray has been deemed safe as an agent for use on high-voltage systems. The possibility of current leakage back to the nozzle, and ultimately the firefighter, is insignificant based on testing data published in the Fire Protection Research Foundation report *Best Practices for Emergency Response to Incidents Involving Electric Vehicles Battery Hazards: A Report on Full-Scale Testing Results*. Firefighting foams are not considered to be effective for these chemistries because they lack the ability to cool sufficiently and can conduct electricity. There is also some evidence that foams might actually encourage thermal runaway progression by insulating the burning materials and exacerbating heat rise.

Firefighting dry chemical powders can eliminate visible flame. However, they also lack the ability to cool burning battery components. Quite often, even if visible flame is removed, the thermal runaway inside the battery will continue resulting in reignition. Carbon dioxide and inert gas suppressing agents will also eliminate visible flame but will likely not provide sufficient cooling to interrupt the thermal runaway process. ESS with clean agent suppression systems installed have ventilation systems that are tied in with the fire detection and control panel so that the HVAC shuts down and dampers close to ensure the agents have sufficient hold times at the proper concentration levels to be effective suppressants. In some fire suppression systems, the HVAC recirculates and does not shut down and provides a means of dispersing the clean agents. Responders must ensure adequate hold time has occurred prior to accessing battery room/container. Manufacturer-recommended times should be made clear. These agents might also reduce flammability by suppressing oxygen levels, but data has identified that flammable gases will continue to be produced due to the continued heating and could create an

environment ripe for flashover or backdraft when oxygen is reintroduced into the system.

C.5.2 Lead-Acid, Nickel-Cadmium, and Other Aqueous Battery Technologies. Lead-acid, nickel-cadmium, and other aqueous batteries are a very familiar chemistry to firefighters. However, though the chemistries employed in ESS are similar to those that would be found in battery backup systems, they can be expected to be found in much larger arrays. The size of the battery system is certainly a factor when determining suppression agent requirements, strategy, and tactics.

Overcharging can lead to overheating and production of hydrogen gas, case swelling, and electrolyte leakage. Large fires can be treated as hazardous materials events.

Water, powders, inert gases, and carbon dioxide are all considered acceptable suppression agents for small fires involving these batteries. However, if the fire is large, water will be the preferred agent because of its superior accessibility, portability, and cooling effectiveness.

C.5.3 Flow Batteries. Flow batteries do not pose flammability risks like more solid batteries, and the fire load is comparably smaller as most of the mass of the system is nonflammable liquid. Though the plastics comprising the balance of the system might pose a fire risk, in general, the system is mostly nonflammable and does not contain many ignition risks beyond the power electronics, which are typically housed separately. Under certain extreme conditions, such as exposure to significant heat, the system can generate hydrogen, which is likely to be captured in the large tanks and vented in a controlled manner.

The system does pose toxicity risks, as electrolyte is typically composed of hydrochloric acid, sulfuric acid, or some combination of the two. Electrolyte capacity can be from tens of gallons to thousands of gallons in each containerized system. Spill containment is an inherent part of a flow battery design.

In the case of zinc bromine (ZnBr) flow batteries, the bromine or hydrobromic acid can pose a health risk. Though unlikely, the vanadium oxide in vanadium flow batteries might form trace, salt-like deposits, which can also pose a health risk. When dealing with failures involving either type of system, it is recommended to wear PPE, including SCBA, at all times.

C.5.4 Sodium Sulfur (NaS) Batteries. Sodium sulfur batteries operate at very high temperatures during normal operation. Though these batteries have become safer over time, there are cases where they have caught fire. NaS fires are very energy dense and cannot, per manufacturer recommendations, be extinguished with water, which could ultimately make them far worse. Sulfur dioxide (SO₂), hydrogen sulfide (H₂S), and other sulfur-based gases can be generated during a fire and can damage the human respiratory system. Proper monitoring equipment and tactics should be employed to gauge the level of detectable gases during fire and post-fire events.

When NaS batteries are deployed, it is advised that fire services work with owner/operators or system owners to develop appropriate standard operating procedures for dealing with NaS emergencies.

C.6 Air Monitoring. Air monitoring should be a priority for responders during and after any ESS emergency. Though the ESS might include an air-monitoring system, it is recommended that the responding fire companies use 4-meter or other gas detection equipment to determine toxic gas levels. Many fire departments carry single gas carbon monoxide meters that can be used to offer limited data on the condition of the ESS environment.

When testing the involved areas, responders should be aware that hydrogen can give an erroneous reading on the carbon monoxide meter because there is a cross-sensitivity with hydrogen. Full PPE and SCBA should always be used during a fire and post-fire event.

The battery room or building might employ a fixed inert gas or other oxygen-displacing fire suppression system. When activated, these agents will displace oxygen from the environment in an effort to control flame. This impact on oxygen levels can impact the lower explosive limit (LEL). Begin metering in areas outside the affected BESS room to establish baseline readings. These areas should include floors above and below the BESS, corners, low-lying areas, and areas out of the path of smoke/gas travel, including near ventilation points.

C.7 Fire Detection and Suppression.

C.7.1 Fire Detection. Battery management systems are primarily designed to monitor temperatures and voltages of cells and modules. They can be designed to shut down the affected charging/discharging circuits in the event of out-of-parameter conditions but might not be able to determine whether a fire is actually occurring. Fire detection should be designed into the ESS installation.

C.7.2 Passive Fire Control. Passive fire control features should be designed to meet the unique challenges of managing electrochemical ESS fires. Passive fire control features should be designed to limit the cascading effects of fire spread. This might include cell to cell (built into the module), module to module (built into the rack/or pack), rack to rack (built into the ESS room or container), or even protection from system to system propagation.

▲ C.7.3 Suppression Tactics. As previously mentioned, battery components are often housed in cabinets or other configurations that can serve to protect the components and thus limit the ability of fire stream penetration. Firefighters should never use piercing nozzles and long penetrating irons. Mechanically damaged cells or puncturing unburned or undamaged cells can result in the immediate ignition of those cells. In addition, internal shorting within the cabinets could create an electrocution risk.

Movement of damaged cells might result in arcing or re-ignition if active material or cells remain in the modules. Modules should not be moved without consultation from qualified personnel.

Ventilation during suppression is critical. Research has shown that Li-ion batteries might continue to generate flammable gases during and after extinguishing. In addition, testing has shown that during sprinkler suppression, removal of combustion and flammable gases emitted from the battery significantly improves the effectiveness of the suppression.

Testing has shown that electrical current leakage back through hose streams will not be a shock hazard when appropriate streams are used and distances maintained. In cases where systems are thoroughly destroyed and electric potential is shown to be minimal, close range engagement with hoses for drowning modules can be performed to provide more direct cooling.

During post-fire operations, SCBA should continue to be worn by all persons near the damaged ESS, especially when systems are in confined or poorly ventilated spaces or have not been sufficiently cooled yet. Gases, and in particular CO, should be monitored during this period, as dangerous buildups have been observed during post-fire testing. If possible, batteries should be monitored for residual heat and temperature, as reignition is a possibility in cells that are not sufficiently cooled.

Care should be taken to secure the area the batteries are located in and ensure that the heat has been removed and that the batteries are not at risk of being electrically shorted or mechanically damaged. This should be done at the guidance of a qualified technician. At this point, the fire scene should be handed over to the owner, operator, or responsible party appointed by the site owner.

Though trace amounts of heavy metals such as nickel and cobalt can be deposited from combustion of the batteries, these elements are not expected to be present in large quantities or in quantities larger than any other similar fire. In most instances, water exposed to the batteries shows very mild acidity, with an approximate pH of 6. Runoff water pH can be monitored during firefighting operations but should not pose a greater risk than normal firefighting run-off.

In unique cases where a system on fire poses little or no risk to the surrounding uninvolved equipment or the environment, it can be reasonable to assume a defensive posture and allow the system to burn itself out. Some typical steps for this approach include the following: local municipal firefighters responding to the scene to make sure that the flames do not spread beyond the property perimeter; having ESS operations personnel arriving at the scene to review the situation and conditions; and then allowing the fire to burn out. This option should only be considered when no risks are posed to the environment and the risk to firefighting operations is otherwise great or unknown. It is up to the site owner/operator to communicate with fire services in the event of an emergency to relay vital system information to fire services.

C.8 Flooding and Seismic Influences. Flooding can induce electrical damage to ESS that should be taken into consideration after water has receded. Battery systems in earthquake-prone zones should be seismically tested and certified for such abuse. Systems damaged in earthquakes might be prone to fire if cells have been mechanically damaged or power electronics are damaged and operating improperly, leading to electrical overcharge or other abuse conditions that can cause fire. In addition, if there is an extended power outage for several days, balance of system power might be out, and ventilation fans or automatic suppression systems might be inoperable, leading to more hazardous fire conditions.

Annex D Overview of Energy Storage Systems Technologies

This annex is not a part of the requirements of this NFPA document but is included for informational purposes only.

D.1 Introduction. ESS can be classified according to the form of energy, and the main categories are mechanical, electrochemical, chemical, electrical, and thermal as depicted in Figure D.1. Hydrogen is a secondary energy carrier that can be produced, along with oxygen. In fuel cells, electricity is produced through the oxidation of a fuel, such as hydrogen, and the reduction of oxygen from the air or an alternate oxygen source. The system comprised of an electrolyzer and a fuel cell is a chemical ESS[1].

The purpose of this annex is to provide insight into the types, features, and applications of currently available ESS that have not been included in the standard in detail and their deployment status. The technologies of focus include, but are not limited to, pumped hydro storage (PHS), compressed air energy storage (CAES), flywheel energy storage (FES), superconducting magnet ESS (SMES), and thermal ESS. These technologies can both store and release electrical energy but are not power generation systems that require a fuel source to function. These technologies will also be compared to other technologies, including a variety of batteries and capacitors that have been evaluated in detail and fall within the jurisdiction of the standard. The standard recognizes that there are a large variety of ESS technologies, and some will be excluded for a multitude of reasons, including inapplicability to grid storage, immaturity (commercialization is estimated to require more than 5 years), size, or the requirement that the installation and safety validation needs specialized expertise or conditions that cannot be generalized as effectively as the more common technologies. Grid ESS technologies range from over 100 GW of installed pumped hydro plants to experimental metal-air batteries and flywheels. Each offers unique advantages in terms of energy, power, lifetime, applicability, technical maturity, and cost. The disadvantages can be equally diverse, from geographic limitations (CAES) to cycle life issues (batteries). Also, grid ESS must deal with location-specific competition from alternative solutions such as added transmission and natural gas plants.

Pumped hydro and CAES are mature with well-documented use, so batteries and flywheels are currently the primary focus

for enhanced grid-scale safety. For these systems and possibly some others, the associated failure modes for grid-scale power and energy requirements have not been well-characterized, and this results in much larger uncertainty around the risks and consequences of failures. This uncertainty around system safety can lead to barriers to adoption and commercialization success but more importantly, the determination of impacts to health and the environment. To address these risks, it is recommended that efforts be concentrated in the following areas:

- (1) Materials science R&D extending into all device components
- (2) Engineering controls and system design
- (3) Simulation and modeling
- (4) System testing and analysis
- (5) Commissioning and field system safety protocols

The key modus operandi for using the areas outlined in the preceding list is to develop understanding and confidence by relating results at one scale to expected outputs at a higher scale. It is important to try and predict the interplay between components, as well as protecting against unexpected outcomes when multiple failure modes are present at the same time. Extensive research, modeling, and validation testing are required to address these challenges. This warrants building a reliable safety program by combining hazard analysis approaches with research and commissioning plans. The primary mandate is to identify, respond to, and mitigate any observed safety events that are critical for the validation of safe ESS.

D.2 Technical Comparison and Future Potential for ESS. It is apparent that there are a wide range of different ESS technologies, and it is highly likely that more will emerge in the next 10 to 15 years. Different applications with varying requirements will determine what features are needed, and this makes it difficult to conduct a comprehensive assessment and comparison. Not all ESS are commercially available in the current ranges for rated power (1 kW to 1 GW) and energy capacity (0.1 kWh to 100 GWh). Most of the technologies could be installed or upgraded with even larger power output and energy capacity (at least double), due to the modular design options. Figure D.2(a) shows a very broad and generalized comparison of storage technologies and their applications.

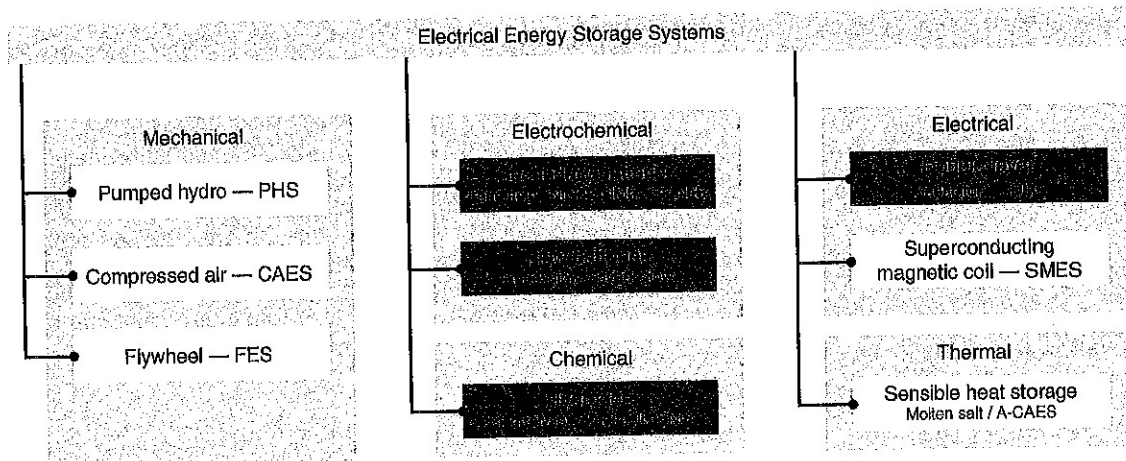

FIGURE D.1 Classification of Electrical ESS. (Source: Fraunhofer ISE.)

Some exceptions are PHS and systems with underground storage for H_2 , SNG, and CAES. The energy-to-power (ETP) ratio adds an additional system characterization factor known as the discharge time [1 sec (short) to several months (long)] as a function of energy density. The higher the power and energy density, the lower the required volume for the system. There are many trade-offs for how each ESS is positioned with respect to performance based on these properties and best fit for key markets (utility, consumer, and renewable) and the applications within them. Figure D.2(b) illustrates which ESS is or could become feasible for what applications, and where further research, development, and scale-up are necessary.

It can be concluded that many different types of ESS will be required to cover all the applications outlined, as no single superior universal storage technology exists[1].

D.3 Mechanical ESS. The most common mechanical ESS are pumped hydroelectric power plants [pumped hydro storage (PHS)], compressed air energy storage (CAES), and flywheel energy storage (FES).

D.3.1 Pumped Hydroelectric Storage (PHS). The key elements of a pumped hydroelectric (pumped hydro) system include turbine/generator equipment, a waterway, an upper reservoir, and a lower reservoir. The turbine/generator is similar to equipment used for normal hydroelectric power plants that do not incorporate storage. Pumped hydro systems store energy (charge up) by operating the turbine/generator in reserve to pump water to a higher elevated reservoir or vessel when inexpensive energy is available and during off-peak hours. The water is later released (discharged) to return to the lower reservoir when electricity is needed and more valuable. When the water is released, it goes through the turbine, which rotates the generator to produce electric power. PHS is one of the oldest grid storage technologies (used in Europe since 1890) and likely the most widespread, accounting for almost 99 percent (127 GW) of the worldwide installed electrical storage capacity as of September 2012[2]. This is about 3 percent of the global generation capacity[3].

PHS capabilities will vary from plant to plant. The amount of energy stored in a PHS facility depends on the height difference between the lower and upper reservoirs as well as the volume of the upper reservoir. PHS plants have efficiencies between 60 percent and 85 percent, with larger elevation differences giving better efficiency[4]. Some newer plants have variable speed capabilities, which increases the load following and frequency regulation capabilities. The ability of PHS plants to ramp from 0 percent to 100 percent power output in several minutes, as well as quickly change their power output in response to automatic generation control (AGC) signals, makes them suitable for a wide range of applications, including spinning reserve, load following, frequency regulation, and voltage regulation. Typical discharge times range from several hours to a few days. Other advantages are the very long lifetime and practically unlimited cycle stability of the installation. PHS also has significant drawbacks. Because of its large land use, pumped hydro cannot provide distribution-level or end-user services. Topographically, PHS is usually unsuitable for arid or flat regions, many of which have abundant wind resources. PHS can be used in conjunction with water towers in areas where the topography is unfavorable for PHS. The main applications are for energy management via time shift, namely nonspinning and supply reserve.

D.3.2 Compressed Air Energy Storage (CAES). For compressed air (gas) energy storage systems (CAES), air is used as a storage medium due to its availability. Off-peak electricity is used to compress air and store it in an underground or underwater structure (cavern, aquifer, abandoned mine, or reservoir) or an aboveground system of vessels or pipes. When electricity is needed, the compressed air is heated or mixed with natural gas and burned and then expanded to drive a modified gas turbine that produces electricity. The energy storage capacity of CAES is determined by the volume of the storage reservoir while the power capacity is determined by the turbine used to generate electricity. Since natural gas-fired turbines spend approximately half of their fuel compressing the air intake, using already compressed air requires considerably less fuel

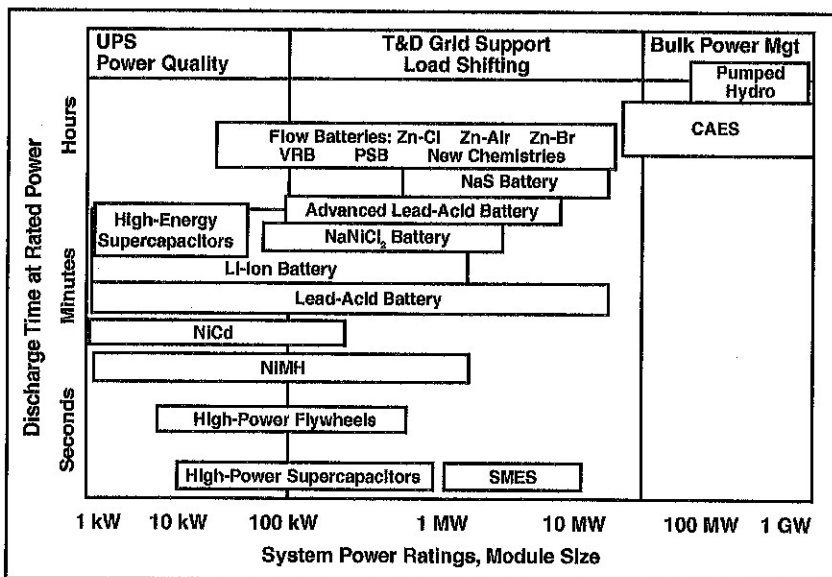

FIGURE D.2(a) Positioning of Energy Storage Technologies. (Source: U.S. Department of Energy, Energy Storage System Guide for Compliance with Safety Codes and Standards.)

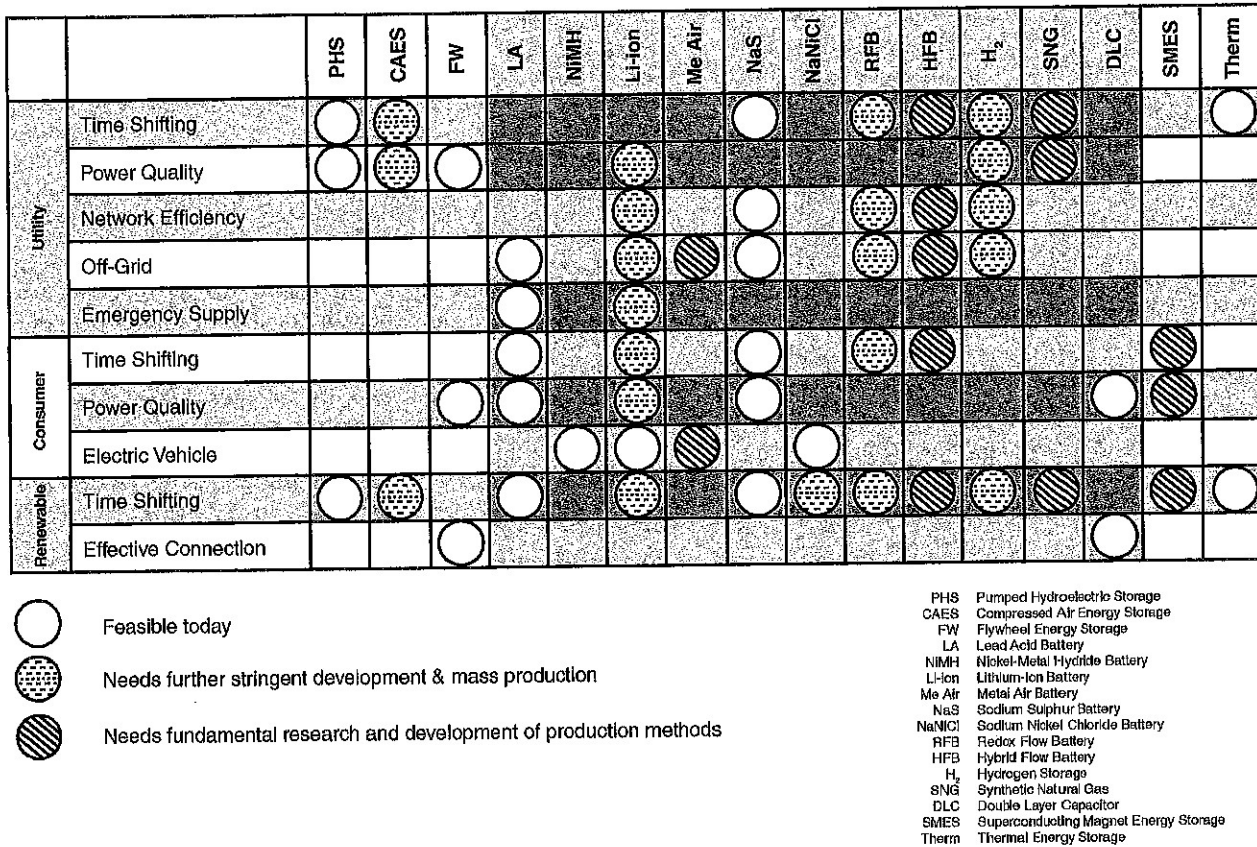

FIGURE D.2(b) ESS Feasibility, Future Potential, and Need for Development by 2030. (Source: Fraunhofer ISE.)

than a conventional natural gas-fired power plant. For below-ground CAES, the heat-rate can range from 3845 Btu/kWh to 3860 Btu/kWh; for above-ground CAES, the heat rate is around 4000 Btu/kWh. Simple-cycle natural gas turbines have a heat-rate between 9000 and 10,000 Btu/kWh. If the heat released during compression is dissipated by cooling and not stored, the air must be reheated prior to expansion in the turbine. This process is called diabatic CAES and results in low overall efficiencies of less than 50 percent. Diabatic technology is well proven, with plants that have high reliability and are capable of start-up without extraneous power.

CAES is the second largest grid energy storage technology after pumped hydro. It has been used since the 19th century for different industrial applications, including mobile ones. Currently, there are only a few large-scale plants (110 MW to 300 MW) in operation worldwide, and growth in CAES capacity has been minimal in recent years. However, this should change over the next decade due to government support for projects featuring new technologies like adiabatic and isothermal compression and expansion systems that do not require fuel[5]. In an adiabatic CAES process, the released heat is retained in thermal storage and used again during expansion in a turbine. The advantage of CAES is its large capacity. In general, CAES is less efficient and slower responding than PHS, which makes the technology less applicable to short-duration, fast-response services like frequency regulation. In addition to low efficiency, there are geographic limitations in terms of locating a suitable underground reservoir[6].

D.3.3 Flywheel Energy Storage (FES). Flywheels store electricity in the form of rotational kinetic energy. The energy density of a flywheel ESS depends on the rotational speed, the mass distribution, and the size of the spinning rotor. The main components of a flywheel include a rotating body or cylinder comprised of a rim attached to a shaft contained in a compartment. There are also bearings and the transmission device, which is a motor/generator mounted onto a stator. The stator is the static part of the assembly, usually at the top of the tower.

The energy is maintained in the flywheel by keeping the rotating body at a constant speed. An increase in the speed produces a higher amount of energy stored. The transmission device is utilized to accelerate the supply of flywheel electricity. If the flywheel's rotational speed is reduced, electricity can be extracted from the system by the same transmission device. First generation flywheels have been available since 1970, consisting of a large steel rotating body on mechanical bearings. Advanced FES systems have rotors made of high-strength carbon fiber, suspended by magnetic bearings and spinning at speeds from 20,000 rpm to over 50,000 rpm in a vacuum enclosure. Flywheel system level safety issues require special considerations, including mechanical containment testing and modeling, vacuum loss testing, and material fatigue testing under stress.

Notable performance features of flywheel ESS are high-power density, excellent cycle stability/life, low maintenance, and the incorporation of environmentally inert materials.

Flywheel operation has a high level of self-discharge due to air resistance and bearing losses and as a result, suffer from low current efficiency. Smaller flywheel systems capable of charging and discharging for several seconds are widely used for uninterruptible power supply (UPS) applications. Larger commercially deployed high-speed flywheel technology (100 kW to 25 kWh) is used in the industrial power field for applications such as frequency regulation. Flywheels are commonly used in hybrid ESS configurations, and efforts are currently being made to optimize designs for long duration storage operation (up to several hours) for use in vehicles and power plants.

D.4 Electrical ESS. The two most common electrical ESS are capacitors and superconducting magnetic energy storage (SMES). Electrochemical double-layer capacitors (DLC) or supercapacitors are a technology that has been known for 60 years. They fill the gap between classical capacitors used in electronics and batteries, due to almost unlimited cycle stability, extremely high-power capability, and high orders of magnitude better energy storage capability relative to traditional capacitors. Therefore, supercapacitors have a large development potential that could lead to much greater capacitance and energy density, thus enabling compact designs in the future.

D.4.1 Superconducting Magnetic Energy Storage (SMES). Superconducting magnetic energy storage (SMES) systems function according to an electrodynamic principle. The energy is stored in the magnetic field created by the flow of direct current in a superconducting coil, which is maintained below its superconducting critical temperature. At the discovery of superconductivity approximately 100 years ago, a temperature of about 4 K was needed. Important research has now produced available superconducting materials with higher critical temperatures and stability at around 100 K. The main component of this storage system is a coil made of superconducting material. Additional system components include power conditioning equipment and a cryogenically cooled refrigeration system.

The main advantage of SMES is the rapid response time that allows the power demand to be available almost instantaneously. The system is also characterized by its high overall round-trip efficiency (85 percent to 90 percent) and the very high power output that can be provided for a short period of time. There are no moving parts in the main portion of SMES, but the overall reliability still depends heavily on the refrigeration system. In principle, the energy can be stored indefinitely if the cooling system is operational, but longer storage times are limited by the energy demand of the refrigeration system.

Large SMES systems with more than 10 MW power are mainly used in particle detectors for high-energy physics experiments and nuclear fusion. Currently, a few small SMES products are commercially available as these are mainly used for power quality control in manufacturing plants such as microchip fabrication facilities[7].

D.5 Thermal Energy Storage. Thermal (energy) storage systems store available heat by different means in insulated containment for later release in different industrial and residential applications, such as space heating or cooling, hot water production, or electricity generation. Thermal storage systems are deployed to overcome the disconnect between demand and supply of thermal energy and as a result become important for the integration of renewable energy sources.

Thermal storage can be subdivided into different technologies, including storage of sensible heat, storage of latent heat, and thermo-chemical (adsorption and absorption) storage[8]. The storage of sensible heat is the most common of the technologies with the domestic hot water tank as an example. The storage medium can be a liquid such as water or thermo-oil or a solid such as concrete or the ground. Thermal energy is stored only by a change of temperature of the storage medium. The capacity of a storage system is defined by the specific heat capacity and the mass of the medium used.

Latent heat storage is achieved by using phase change materials (PCMs) as storage media. There are organic (waxes) and inorganic PCMs (salt hydrates) available for such storage systems. Latent heat is the energy released during a phase change such as the melting of ice. It is also called "hidden" heat, because the energy transfer is isothermal. Most PCMs use the solid-liquid phase change, such as molten salts, as the medium for concentrated solar power (CSP) plants[9]. The advantage of latent heat storage is its capacity to store large amounts of energy in a small volume and with a minimal temperature change for efficient heat transfer.

Adsorption and absorption storage systems work as thermo-chemical heat pumps under vacuum conditions and have a more complex design. Heat from a high-temperature source heats up an adsorbent (e.g., silica gel or zeolite), and vapor from the working fluid (e.g., water) is desorbed from this adsorbent and condensed in a condenser at low temperatures. The heat of condensation is withdrawn from the system. The dried adsorbent and the separated working fluid can be stored as long as desired. During the discharging process the working fluid takes up low-temperature heat in an evaporator. Subsequently, the vapor of the working fluid adsorbs on the adsorbent and the heat of adsorption is released at high temperatures[10]. Depending on the adsorbent/working fluid combination, the temperature level of the released heat can be up to 392°F (200°C)[8], and the energy density is up to three times higher than that of sensible heat storage with water.

It is mainly sensible and latent heat storage systems that are important for thermal ESS. Concentrated solar power (CSP) plants primarily produce heat that can be easily stored before conversion to electricity. State-of-the-art technology is a two-tank system for solar power plants, with one single molten salt as the heat transfer fluid and storage medium[11]. The molten salt is heated by solar radiation and then transported to the hot salt storage tank. To produce electricity, the hot salt passes through a steam generator that powers a steam turbine. Subsequently, the cold salt (still molten) is stored in a second tank before it is pumped to the solar tower again. The main disadvantages are the risk of liquid salt freezing at low temperatures and the risk of salt decomposition at higher temperatures. Typical salt mixtures such as Na-K-NO₃ have freezing temperatures >392°F (>200°C).

It is important to know if a pressurized tank is needed for the thermal storage or if a nonpressurized compartment can be used. In liquid systems, a heat exchanger can be used to avoid the need for a large pressurized tank for the liquid. A dual-media approach (salt and oil) must be used to cover the temperature range from 122°F to 1202°F (50°C to 650°C)[12]. Direct contact between the pressurized air and the storage medium in a solid thermal storage system has the advantage of a high surface area for heat transfer.

Annex E Permits, Inspections, Approvals, and Connections

This annex is not a part of the requirements of this NFPA document but is included for informational purposes only.

E.1 Permits. Permits should conform to E.1.1 through E.1.4.

E.1.1 Application. Permits should be secured from and issued by the authority having jurisdiction for the following:

- (1) Installation of new stationary ESS
- (2) Additions, alterations, or renovations to existing stationary ESS
- (3) Recommissioning or decommissioning of existing ESS
- (4) Placement of mobile ESS
- (5) Stationary installations of mobile or portable ESS
- (6) A change in the occupancy classification of a building or facility in which a stationary ESS is installed

E.1.2 Content. Permits should be issued by and in accordance with the procedures of all authorities having jurisdiction and should bear the name and signature of each authority having jurisdiction or their designated representative(s). In addition, the permit should indicate the following:

- (1) Purpose of the ESS for which the permit is issued
- (2) Type of ESS, size, weight broken down by subcomponents or subsystems, type, and amount of any hazardous materials, general arrangement of the system, and extent of work to be performed
- (3) Address where the ESS is to be installed and operated
- (4) Name and address of the permittee
- (5) Permit number and date of issuance
- (6) Period of validity of the permit
- (7) Inspection requirements

E.1.3 Issuance of Permits. The authority having jurisdiction should be authorized to establish and issue permits, certificates, notices, and approvals, or orders pertaining to any ESS as covered in E.1.1. Once permitted, the owner of the ESS, or their designated agent, should be responsible for the maintenance of the system and the abatement of any hazardous conditions that exist that are associated with the system or are external to and could adversely affect the system.

E.1.4 Revocation of Permits. Revocation of permits should conform to the following:

- (1) The authority having jurisdiction should be permitted to revoke a permit or approval issued if any violation of this standard is found on inspection or where the ESS is not in accordance with the approved plans and specifications on which the permit or approval was based.
- (2) Any attempt to defraud or otherwise deliberately or knowingly violate the requirements prescribed by this standard should constitute a violation of this standard. Such violations should be cause for immediate revocation of permits for the ESS issued by the authority having jurisdiction.
- (3) Any person who operates or causes an ESS that has a revoked permit to be operated should be in violation of this standard.

E.2 Inspections and Approvals. The inspection and approval of an ESS should conform to E.2.1 through E.2.5.

E.2.1 Application. On completion of the installation of any new ESS or work on an existing ESS requiring a permit the person, firm, corporation, or system integrator making the installation should notify the authority having jurisdiction, who

should inspect or authorize their designated representative(s) to inspect the installation.

E.2.2 Inspection. Where those responsible for inspection of the ESS find the installation to be in conformity with this standard, the authority having jurisdiction should issue to the owner of the system a certificate of approval. A duplicate copy of the certificate of approval should be provided in writing to any supplier of energy to the system authorizing the connection of energy to the system. When the approval has a specific date of expiration, as in the case of a temporary system installation, the certificate of approval should be issued to expire at the time to be stated therein and should be revocable by the authority having jurisdiction for cause.

E.2.3 Concealment. Any portion or component of the system that is to be hidden from view by permanent placement of parts of the system or construction associated with the installation should notify the authority having jurisdiction and should not conceal it until inspected and approved by the authority having jurisdiction or their designated representative(s).

E.2.4 Reinspection. The authority having jurisdiction should be permitted to visit any ESS installation to inspect such system for compliance with the plans and specifications that were submitted with the permit application and, with the inspection of the system, formed the basis for validating compliance with this standard.

E.2.5 Revocation of Permits. The authority having jurisdiction should be permitted to revoke a permit or approval issued if any violation of this standard is found on inspection or in case there have been any false statements or misrepresentations submitted in the application or plans and specifications on which the permit or approval was based.

E.3 Connection to an Energy Supply. Connections of the ESS to any energy source should conform to E.3.1 and E.3.2.

E.3.1 Authorization. It should be unlawful to connect the ESS to a supply of energy to the system or to supply energy from the system for any purpose unless the ESS has been permitted and approved in accordance with the requirements of this standard.

E.3.2 Temporary Consideration. By special permission of the authority having jurisdiction and the applicable entities to supply and/or receive energy from the system, energy should be permitted to be supplied on a temporary basis for specific needs associated with testing, commissioning, or inspecting the ESS.

△ Annex F Fire and Building Codes A Short History on Stationary Storage Battery Systems

This annex is not a part of the requirements of this NFPA document but is included for informational purposes only.

F.1 General. The National Fire Protection Association's (NFPA) development of NFPA 855, *Standard for the Installation of Stationary Energy Storage Systems*, is not the first effort to address the safety of energy storage systems. Energy storage technologies have long been addressed by *NFPA 70, National Electrical Code (NEC)*, along with building and fire codes under the topic stationary storage battery systems.

More focused treatment of battery systems began with the 1997 edition of the *ICC Uniform Fire Code (UFC)*. Before that various standards and model codes provided safety require-

ments that addressed batteries both as primary sources of electrical energy and for emergency backup power. Because of the amount of acid electrolyte in lead-acid batteries, when viewed in the aggregate and individually, they were being regulated for the hazardous material properties of the electrolyte, which then triggered more stringent high-hazard occupancy construction and protection requirements. As a result, the telecommunications industry sought a change to the UFC that addressed the operating hazards associated with batteries in their facilities without triggering the more stringent building and fire code requirements.

This treatment of battery systems in building and fire codes based upon the chemistry and amount of electrolytes was uniform across the three legacy model codes produced by the Building Officials and Code Administrators International, International Conference of Building Officials, and Southern Building Code Congress International that existed prior to their merger and the creation of the International Code Council series of model codes completed in 2000.

F.2 Historical Development of Codes.

F.2.1 1997 Uniform Fire Code. Section 6401 of the 1997 edition of the *Uniform Fire Code*, based on approved modifications to the 1994 edition, contained the following requirements for stationary lead-acid battery systems:

SECTION 6401 SCOPE. Stationary lead-acid battery systems having a liquid capacity of more than 100 gallons (378.5 L) used for facility standby power, emergency power or uninterrupted power supplies shall be in accordance with Article 64. Stationary lead-acid battery systems with individual lead-acid batteries exceeding 20 gallons (75.7 L) each shall also comply with Article 80. [UFC, 1997]

The requirements addressed were as follows:

- (1) Safety venting
- (2) Occupancy separation
- (3) Spill control
- (4) Neutralization
- (5) Ventilation
- (6) Signs
- (7) Seismic protection
- (8) Smoke detection

Note that the scope was not open ended. The individual battery limitation was set at 20 gallons and exceeding that amount per battery still triggered the more extensive hazardous material provisions in the UFC.

The topics addressed were based upon normal operation. Overcharging, thermal runaway, or other abnormal operational conditions were not considered, if in fact they were even recognized safety concerns at the time.

F.2.2 2000 International Code Council Codes. The targeted regulation of stationary lead-acid battery systems that began with the 1997 *Uniform Fire Code* was carried forward as the three legacy model code organizations merged as the International Code Council and completed work on the development of, among others, the 2000 *International Fire Code* and 2000 *International Building Code*. The topics covered were as follows:

- (1) Safety venting
- (2) Room design and construction
- (3) Spill control and neutralization
- (4) Ventilation

- (5) Signs
- (6) Seismic protection
- (7) Smoke detection

The threshold for application was reduced to 50 gal (190 L) and the 20 gal (75 L) per battery limitation was eliminated compared to the 1997 UFC. In addition, the *International Building Code* classified the battery storage as incidental use areas and added an exemption from the high-hazard use classification.

The purpose of the requirements was to provide for relief for certain battery system applications from being designated a high-hazard occupancy due to the amount of hazardous materials that were contained within the batteries. In practice, if a stationary lead-acid battery system satisfies these requirements then the facility containing those batteries is not regulated as a hazardous material occupancy and would not be designated a high-hazard use. That said, if the hazardous material maximum allowable quantities (MAQ) relative to the amount of electrolyte was exceeded then the battery system would result in a hazardous material classification.

The requirements for stationary lead-acid battery systems were brought into the 2000 *International Fire Code* as Section 608 with the topics listed in F.2.2 addressed. For room design and construction, the user was pointed to the 2000 *International Building Code* where the battery systems were identified as an incidental use area and required to be separated from the remainder of the occupancy by fire resistance rated assemblies.

As with the 1997 UFC, the topics addressed were based upon normal operation. Overcharging, thermal runaway, or other abnormal operating conditions were not considered or recognized at the time.

F.2.3 2003 International Code Council Codes and NFPA 1, Fire Code. In Section 608 of the 2003 *International Fire Code*, the scope of lead-acid battery systems was changed to lead-acid battery systems using vented (flooded) lead-acid batteries. A new Section 609 was added to the IFC covering valve-regulated lead-acid battery systems and contained similar language. The requirements in the 2003 *International Building Code* remained the same applying to lead-acid batteries generally.

Section 608 vented (flooded) lead-acid batteries covered the following:

- (1) Safety venting
- (2) Room design and construction
- (3) Spill control and neutralization
- (4) Ventilation
- (5) Signs
- (6) Seismic protection
- (7) Smoke detection

Section 609 valve-regulated lead-acid battery systems covered the following:

- (1) Safety venting
- (2) Thermal runaway
- (3) Room design and construction
- (4) Spill control and neutralization
- (5) Ventilation
- (6) Cabinet ventilation
- (7) Signs
- (8) Seismic protection
- (9) Smoke detection

It should be noted that NFPA 1, *Fire Code*, did not have any requirements for stationary storage battery systems in the 2000 edition. The requirements were added to the 2003 edition of NFPA 1 from the same source used for the 2000 edition of the *International Fire Code*, the *Uniform Fire Code*, along with the added coverage of valve-regulated lead-acid batteries. The NFPA 1, *Fire Code*, battery storage provisions then remained unchanged until the 2009 edition.

F.2.4 2006 International Code Council Codes and NFPA 1, *Fire Code*. In the 2006 edition of the *International Fire Code* (IFC), Section 608 was rewritten to cover the following:

- (1) Flooded lead-acid batteries
- (2) Flooded nickel-cadmium (Ni-Cad) batteries
- (3) Valve-regulated lead-acid (VRLA) batteries
- (4) Lithium-ion batteries

This edition of the IFC signaled a recognition for and the introduction of new chemistries such as nickel-cadmium and lithium-ion batteries.

The same general topics were covered in the revisions to the 2003 IFC that were implemented as the 2006 IFC, including the need for a separate room or space created in accordance with the building code. That said, beyond the separate room, only the IFC signage, seismic protection, and smoke detection

requirements applied to the lithium-ion batteries. Figure F.2.4 provides the overview of the 2006 IFC provisions.

There were no changes made between the 2003 and the 2006 edition of NFPA 1, *Fire Code*. As such, it continued to apply only to the flooded lead-acid and valve-regulated lead-acid batteries.

F.2.5 2009 International Code Council Codes and NFPA 1, *Fire Code*. The 2009 edition of NFPA 1, *Fire Code*, contained new provisions that added lithium-ion and nickel-cadmium technologies, and both NFPA 1 (see Table F.2.5) and the IFC (see Figure F.2.5) contained new provisions that added lithium metal polymer batteries to the list of regulated battery technologies. The key difference in treatment between lithium-ion batteries and lithium metal polymer batteries was the requirement for thermal runaway protection for lithium metal polymer batteries. It should be noted that although Table 52.1 of the 2009 edition of NFPA 1 indicates no thermal runaway requirement for lithium-ion batteries, the technical language in 52.3.2 indicates thermal runaway was required for lithium-ion as well.

Thermal Runaway. VRLA and lithium-ion and lithium metal polymer battery systems shall be provided with a listed device or other approved method to preclude, detect, and control thermal runaway. [1:52.3.2, 2009]

**TABLE 608.1
BATTERY REQUIREMENTS**

REQUIREMENT	NONRECOMBINANT BATTERIES		RECOMBINANT BATTERIES	
	Flooded Lead Acid Batteries	Flooded Nickel-Cadmium (Ni-Cd) Batteries	Valve Regulated Lead Acid (VRLA) Batteries	Lithium-Ion Batteries
Safety caps	Venting caps (608.2.1)	Venting caps (608.2.1)	Self-sealing flame-arresting caps (608.2.2)	No caps
Thermal runaway management	Not required	Not required	Required (608.3)	Not required
Spill control	Required (608.5)	Required (608.5)	Not required	Not required
Neutralization	Required (608.5.1)	Required (608.5.1)	Required (608.5.2)	Not required
Ventilation	Required (608.6.1; 608.6.2)	Required (608.6.1; 608.6.2)	Required (608.6.1; 608.6.2)	Not required
Signage	Required (608.7)	Required (608.7)	Required (608.7)	Required (608.7)
Seismic protection	Required (608.8)	Required (608.8)	Required (608.8)	Required (608.8)
Smoke detection	Required (608.9)	Required (608.9)	Required (608.9)	Required (608.9)

FIGURE F.2.4 2006 International Fire Code Battery Requirements. (Source: 2006 *International Fire Code*.)

A change to the *International Building Code (IBC)* unrelated to battery storage systems limited all incidental uses, the classification the IBC applies to battery systems, to no more than 10 percent of the area of the floor of the building they are located on.

F.2.6 2012 and 2015 International Code Council Codes and NFPA 1, Fire Code. Between the 2009 and 2012 editions of the fire codes, there were insignificant changes made to the requirements associated with battery systems. Between the 2012 and 2015 editions no changes were made. Essentially the 2009 and 2015 editions were the same with respect to battery systems.

F.2.7 2018 International Code Council Codes and NFPA 1, Fire Code. Recognizing the development of new battery technolo-

gies and the evolution of battery storage into a more robust and wider energy storage industry in relation to the requirements in the various fire and building codes, the International Code Council's Fire Code Action Committee created an Energy Storage Systems Work Group (ESS WG). The work of the ESS WG resulted in a new chapter being approved for inclusion in the 2018 *International Fire Code* — Chapter 12, Energy Systems — into which all the key energy-storage-related requirements (including batteries) were moved including the following:

- (1) Emergency and stand-by power systems
- (2) Solar photovoltaic power systems
- (3) Stationary fuel cell power systems
- (4) Electrical energy storage systems

Table F.2.5 Battery Requirements

Requirement	Nonrecombinant Batteries		Recombinant Batteries		Other
	Flooded Lead-Acid	Flooded Nickel-Cadmium (Ni-Cd)	Valve-Regulated Lead-Acid (VRLA)	Lithium-Ion	Lithium Metal Polymer
Safety caps	Venting caps	Venting caps	Self-resealing flame-arresting caps	No caps	No caps
Thermal runaway management	Not required	Not required	Required	Not required	Required
Spill control	Required	Required	Not required	Not required	Not required
Neutralization	Required	Required	Required	Not required	Not required
Ventilation	Required	Required	Required	Not required	Not required
Signage	Required	Required	Required	Required	Required
Seismic control	Required	Required	Required	Required	Required
Fire detection	Required	Required	Required	Required	Required

[1:Table 52.1, 2009]

**TABLE 608.1
BATTERY REQUIREMENTS**

REQUIREMENT	NONRECOMBINANT BATTERIES		RECOMBINANT BATTERIES		OTHER
	Flooded Lead Acid Batteries	Flooded Nickel-Cadmium (Ni-Cd) Batteries	Valve Regulated Lead Acid (VRLA) Batteries	Lithium-Ion Batteries	Lithium Metal Polymer
Safety caps	Venting caps (608.2.1)	Venting caps (608.2.1)	Self-resealing flame-arresting caps (608.2.2)	No caps	No caps
Thermal runaway management	Not required	Not required	Required (608.3)	Not required	Required (608.3)
Spill control	Required (608.5)	Required (608.5)	Not required	Not required	Not required
Neutralization	Required (608.5.1)	Required (608.5.1)	Required (608.5.2)	Not required	Not required
Ventilation	Required (608.6.1; 608.6.2)	Required (608.6.1; 608.6.2)	Required (608.6.1; 608.6.2)	Not required	Not required
Signage	Required (608.7)	Required (608.7)	Required (608.7)	Required (608.7)	Required (608.7)
Seismic protection	Required (608.8)	Required (608.8)	Required (608.8)	Required (608.8)	Required (608.8)
Smoke detection	Required (608.9)	Required (608.9)	Required (608.9)	Required (608.9)	Required (608.9)

FIGURE F.2.5 2009 International Fire Code Battery Requirements. (Source: 2009 International Fire Code.)

As part of this work the requirements of the former stationary storage battery systems chapter took on the broader application of electrical energy storage systems and addressed the following topics:

- (1) Battery storage system threshold quantities
- (2) Construction documents
- (3) Hazard mitigation analysis
- (4) Fault condition
- (5) Thermal runaway
- (6) Seismic and structural design
- (7) Vehicle impact protection
- (8) Combustible storage
- (9) Testing, maintenance, and repair
- (10) Location and construction
- (11) Stationary battery arrays
- (12) Outdoor installations
- (13) Maximum allowable quantities
- (14) Storage batteries and equipment
- (15) Fire-extinguishing and detection systems
- (16) Specific battery-type requirements
- (17) Capacitor energy storage systems

A major change within this work of the IFC was the introduction of array (unit) spacing as follows:

1206.2.8.3 Stationary battery arrays. Storage batteries, prepackaged stationary storage battery systems and preengineered stationary storage battery systems shall be segregated into stationary battery arrays not exceeding 50 kWh (180 megajoules) each. Each stationary battery array shall be spaced not less than 3 feet (914 mm) from other stationary battery arrays and from walls in the storage room or area. The storage arrangements shall comply with Chapter 10. [IFC, 2018]

This is intended to restrict the amount of energy in arrays (units) and requires a larger footprint for an energy storage system installation due to the 3 ft separation requirement. Exceptions were provided that eliminate lead-acid and nickel-cadmium storage batteries from this limitation, allow listed prepackaged units to have a 250 kWh threshold for separation, and elimination of the limits based upon fire and explosion testing as follows:

Exceptions:

- (1) *Lead acid and nickel cadmium storage battery arrays.*
- (2) *Listed preengineered stationary storage battery systems and prepackaged stationary storage battery systems shall not exceed 250 kWh (900 megajoules) each.*
- (3) *The fire code official is authorized to approve listed, preengineered and prepackaged battery arrays with larger capacities or smaller battery array spacing if large-scale fire and fault condition testing conducted or witnessed and reported by an approved testing laboratory is provided showing that a fire involving one array will not propagate to an adjacent array, and be contained within the room for a duration equal to the fire-resistance rating of the room separation specified in Table 509 of the International Building Code.*

[IFC, 2018]

The IFC relies upon 1- or 2-hour fire-resistant construction to separate systems from the remainder of the building and an assessment that that level of protection can contain the fire impacts within the room or space where a system is installed. A fire and explosion test is needed to document such containment.

The other significant change between the 2015 and 2018 IFC editions was the specification of a maximum allowable battery quantity (see Figure F.2.7).

This was the first time there was an upper limit applied to the amount of energy allowed to be stored in an energy storage system located in a room or space. As with the spacing limitations, there was an exception that could be applied based upon fire and explosion testing as follows:

Exception: Where approved by the fire code official, areas containing stationary storage batteries that exceed the amounts in Table 1206.2.9 shall be treated as incidental use areas and not Group H occupancies based on a hazardous mitigation analysis in accordance with Section 1206.2.3 and large-scale fire and fault condition testing conducted or witnessed and reported by an approved testing laboratory. [IFC, 2018]

Along with the provisions in the 2018 IFC, energy storage language was added to the 2018 *International Residential Code* for the first time. In summary, the new language in the *International Residential Code* required energy storage systems to be listed and precluded them from being installed within the habitable space of a dwelling unit.

The 2018 NFPA 1, *Fire Code*, Chapter 52 contained modifications to the 2015 edition that were very similar to all of the new requirements introduced to the 2018 IFC.

F.2.8 2021 International Code Council Code Development and 2019 NFPA 855, Standard for the Installation of Stationary Energy Storage Systems. While the code revision process was being completed for the 2018 editions of the IFC and NFPA 1, NFPA developed the new standard NFPA 855, *Standard for the Installation of Stationary Energy Storage Systems*. The work of the NFPA 855 technical committee closely tracked and utilized the 2018 language added to the fire codes along with the language from NFPA 853, *Standard for the Installation of Stationary Fuel Cell Power Systems*, for the initial NFPA 855 draft document.

With the adoption and availability of the 2018 editions of the codes, a broader audience was reached that generated additional input to the NFPA 855 committee on the impact of the requirements and questions on how to apply them in differing circumstances such as follows:

- (1) Roof installs
- (2) Open parking garage installs
- (3) Remote installations
- (4) Dedicated ESS buildings
- (5) Array (unit) spacing threshold
- (6) Maximum allowable quantity impact
- (7) Incidental use 10 percent of floor area limitation
- (8) Appropriate requirements based upon technology
- (9) Deflagration prevention/venting
- (10) Suppression system selection
- (11) Fire detection method and where required

Going into the NFPA 855 First Draft process, language improvements were coordinated with work in progress on the proposals for the 2021 editions of the *International Fire Code*, *International Building Code*, and the *International Residential Code*.

Key areas addressed by the current proposals approved by the ICC Fire Code Action Committee and the Fire Code Committee at the proposal hearings for the 2021 edition code change process were as follows:

- (1) Permits, operational as well as installation

**TABLE 1206.2.9
MAXIMUM ALLOWABLE BATTERY QUANTITIES**

BATTERY TECHNOLOGY	MAXIMUM ALLOWABLE QUANTITIES ^a	GROUP H OCCUPANCY
Flow batteries ^b	600 kWh	Group H-2
Lead acid, all types	Unlimited	Not Applicable
Lithium, all types	600 kWh	Group H-2
Nickel cadmium (Ni-Cd)	Unlimited	Not Applicable
Sodium, all types	600 kWh	Group H-2
Other battery technologies	200 kWh	Group H-2 ^c

For SI: 1 kilowatt hour = 3.6 megajoules.

a. For batteries rated in amp-hours, Kilowatt-hours (kWh) shall equal rated battery voltage times the amp-hour rating divided by 1,000.

b. Shall include vanadium, zinc-bromine, polysulfide-bromide, and other flowing electrolyte-type technologies.

c. Shall be a Group H-4 occupancy if the fire code official determines that a fire or thermal runaway involving the battery technology does not represent a significant fire hazard.

FIGURE F.2.7 2018 International Fire Code Maximum Allowable Battery Quantities. (Source: 2018 International Fire Code.)

- (2) Fire and explosion test reliance on new UL 9540A
- (3) Fire remediation actions and personnel
- (4) Commissioning
- (5) Decommissioning
- (6) Operation and maintenance
- (7) Repairs, retrofits, and replacements
- (8) Reused and repurposed equipment
- (9) Toxic and highly toxic gases
- (10) Security of installations
- (11) Occupied work centers
- (12) Walk-in units
- (13) Size and separation threshold reduction
- (14) Maximum allowable quantities as simply a testing trigger
- (15) Remote installations
- (16) ESS dedicated-use buildings designated as an F-1 Group use
- (17) Non-dedicated-use buildings
- (18) Elimination of incidental use 10 percent of floor area restriction and H Group designation
- (19) Explosion control
- (20) Outdoor installations
- (21) Rooftop installations
- (22) Open parking garage installations
- (23) Mobile ESS equipment and operations

Though some of the new language is more conservative, such as the threshold before fire and explosion testing and the requirement for explosion protection for lithium-ion energy storage systems, other proposed changes provide relief from some requirements such as ESS dedicated-use buildings, remote locations, and rooftop and open parking garage installations.

The most restrictive requirements were maintained to address when an energy storage system is installed within a mixed-use occupancy building and it is important to contain an event for life safety and property protection.

The changes proposed for the 2021 I-Codes, and coordinated with the 2019 NFPA 855 development process, are significantly different from the 2018 provisions because of industry participation. The initial language of the 2018 editions of the fire codes and the draft of NFPA 855 are intended to obtain an acceptable level of safety recognizing how challenging and dynamic events from batteries and energy storage systems can

be, whether the system instigates an issue or is a casualty of outside events. Those who verify code compliance and others working on the code language have maintained an open view, and where industry has provided data on different technologies and/or on documented safety practices, or a reduction in exposure hazards, there has been a willingness to modify the requirements in recognition of the new information and data.

F.3 NFPA Fire Protection Research Foundation. There are a few research projects involving the NFPA Fire Protection Research Foundation, Factory Mutual, and Sandia National Laboratories, and the Pacific Northwest National Laboratory on behalf of the DOE Office of Electricity Energy Storage Program, and others that have provided background and understanding for those involved in the code writing process. There are numerous other sources for information, however; the following sources are those best known to many of those involved in the code development process:

- (1) NFPA — for firefighter safety in battery energy storage system fires, see <https://www.nfpa.org/News-and-Research/Resources/Fire-Protection-Research-Foundation/Current-projects/Fire-Fighter-Safety-in-Battery-Energy-Storage-System-Fires>
- (2) NFPA — for lithium-ion batteries hazard and use assessment, see the following:
 - (a) "Lithium Ion Batteries Hazard and Use Assessment"
 - (b) "Lithium Ion Batteries Hazard and Use Assessment — Phase IIB — Flammability Characterization of Lithium Batteries for Storage Protection"
 - (c) "Lithium Ion Batteries Hazard and Use Assessment — Phase III"
- (3) DNV GL — for considerations for energy storage systems fire safety, see <https://www.dnvgl.com/publications/considerations-for-energy-storage-systems-fire-safety-89415>
- (4) Sandia National Laboratory — for energy storage, see <http://energy.sandia.gov/energy/ssrei/energy-storage/>

When industry joined the code-development process, they successfully used additional data specific to their products and operations to bring validity and functionality to proposed code language. The increased industry participation will be a benefit moving forward.

N Annex G Guide for Suppression and Safety of Lithium-Ion Battery (LIB) Energy Storage Systems (ESS)

This annex is not a part of the requirements of this NFPA document but is included for informational purposes only.

N G.1 General.

N G.1.1 Scope. This annex presents information for designers, users, and enforcers planning, approving, or encountering installations of LIB-based ESS. This annex focuses on hazard identification and assessment, firefighting, fire protection, and fire and gas detection. It represents information on LIB properties and characteristics, guidance on implementing minimum safety requirements, maintenance and operation of fire protection systems, and other information that can be used to promote safety of LIB installations.

N G.1.1.1 ESS information could be classified as critical electric infrastructure information (CEII) as defined by the Federal Energy Regulatory Commission (FERC). The sharing of CEII documents might be limited by utilities to prevent their access through the Freedom of Information Act or by persons seeking to disrupt the US bulk electric. Utilities might require non-disclosure agreements and background checks of individuals with an AHJ that will have access to CEII.

N G.1.1.2 This annex describes the use and application of minimum safety requirements in NFPA 855.

N G.1.1.3 This annex does not apply to installations of any non-LIB-based ESS.

N G.1.1.4 Section G.2 addresses fundamentals of hazards associated with LIB-based ESS.

N G.1.1.5 Section G.3 addresses the hazards and risks posed by ESS with hazard mitigation analysis (HMA) and fire risk assessment (FRA).

N G.1.1.6 Section G.4 addresses known failure modes and their associated consequences and mitigation approaches (i.e., bowtie analysis).

N G.1.1.7 Section G.5 addresses application of LIB-based ESS and how location within a building impacts the hazard analysis.

N G.1.1.8 Section G.6 addresses fire protections systems, including system goal, water duration, and water application strategies.

N G.1.1.9 Section G.7 addresses fire and flammable gas detection, including the location, type, and purpose for available technologies.

N G.1.1.10 Section G.9 addresses LIB construction and installation guidance.

N G.1.1.11 Section G.10 addresses guidance on inspection and maintenance for installed LIB fire protection systems.

N G.1.1.12 Section G.11 address guidance on developing a first responder plan for LIB-based ESS installations.

N G.1.2 Purpose.

N G.1.2.1 The purpose of this annex is to help stakeholders, designers, and authorities having jurisdiction (AHJs) understand and implement minimum safety requirements through a permitting and inspection process to ensure efficiency, transparency, and safety in their local communities.

All battery ESS, all ESS dedicated-use buildings, and all other buildings or structures that contain or are otherwise associated with an LIB ESS and that are subject to NFPA 855, should be designed, erected, and installed in accordance with all applicable requirements of NFPA 855, all applicable provisions of the Energy Code, and all applicable provisions of the codes, regulations, and industry standards as referenced in the *Uniform Fire Code*, the Energy Code, and local and state requirements.

N G.1.2.2 As an important first step in protecting public and first responder safety while promoting safe energy storage, the technical committee has developed this annex as a comprehensive set of guidelines for reviewing and evaluating LIB ESS facilities. The annex helps owners, designers, installers, stakeholders, local government officials, AHJs, and developers understand and develop an LIB ESS permitting and development process to ensure efficiency, transparency, and safety in their local communities. This annex provides details about the design, hazard evaluation, installation, operations, appropriate technology application, inspection, and first responder safety processes of LIB-based ESS.

This annex is intended to help owners, designers, installers, stakeholders, local government officials, and AHJs understand the requirements of NFPA 855 to responsibly accommodate battery ESS in their application. This annex lays recommended frameworks, substantive requirements, and examples for residential, commercial, and utility-scale LIB-based ESS.

In some cases, there might be multiple approaches to regulate a certain aspect of battery ESS. Municipalities should choose the option that works best for their application or requirements. Depending on local circumstances or project-specific requirements, the appropriate party might want to include this content or choose to adopt a different approach.

N G.1.3 Minimum Installation Information.

N G.1.3.1 The plans and specifications associated with the ESS and its intended installation, replacement or renewal, commissioning, and use could be required by the AHJ for permitting purposes, but should at least be available to the facility owner/operator by hard or electronic copy that can be shared with first responders. The following documentation should be documented and available where an LIB-based ESS is or will be installed:

- (1) Location and layout diagram of the room or area in which the ESS is to be installed
- (2) Details on fire-resistant-rated assemblies provided or relied upon in relation to the ESS
- (3) Quantities and types of ESS units
- (4) Manufacturer's specifications, ratings, and listings of ESS
- (5) Description of energy storage management systems and their operation
- (6) Location and content of required signage
- (7) Details on fire suppression/protection, smoke or fire detection, gas detection, thermal management, ventilation, exhaust, and deflagration venting systems, if provided
- (8) Support arrangement associated with the installation, including any required seismic support

NG.1.3.2 The following test data, evaluation information, and calculations, as applicable, should be provided in addition to the plans and specifications in accordance with the minimum safety requirements of NFPA 855:

- (1) Fire and explosion test data
- (2) Hazard mitigation analysis
- (3) Calculations or modeling data to determine compliance with NFPA 68 and NFPA 69 as required
- (4) Other test data, evaluation information, or calculations if needed to support deviations from minimum safety requirements

NG.1.3.3 Additional information could be required by AHJs for permitting and prior to commissioning, including, but not limited to, the following:

- (1) Analysis of live loads associated with the ESS installation to ensure building structural integrity
- (2) Shop drawings of fire protection systems
- (3) Electrical one- or three-line diagrams demonstrating method of interconnection, overcurrent protection, and all disconnect locations
- (4) Flood protection or mitigation for installations in flood zones

NG.1.4 Hazard Communication.

NG.1.4.1 General. Most manufacturers provide safety data sheets (SDS) in accordance with the Globally Harmonized Standard (GHS) or equivalent published information outlining the hazards associated with the specific LIBs and associated products of thermal runaway. These publications contain important information for installers, end-users, and first responders. These publications should be used to develop hazard communication tools for personnel and first responders as part of an effective emergency response plan.

NG.1.4.2 Signs and Placards.

NG.1.4.2.1 Hazard communication signs and placards should be located on the exterior of the building or enclosure housing LIB-based ESS. Where multiple enclosures are installed, it isn't necessary to place a sign on every enclosure, but signs should be located at reasonable intervals (see G.1.4.2.1.2).

NG.1.4.2.1.1 Signs on the exterior of a building or enclosure should be sized such that at least one sign is legible at night at a distance of 100 ft (30.5 m) or from the property line, whichever is closer.

NG.1.4.2.1.2 Signs on the exterior of a building or enclosure should be placed at intervals so that at least one sign is visible in every direction that can be reasonably used to approach the installation, enclosure, or building.

NG.1.4.2.2 Signs and placards should be placed at the entrance to a room or designated ESS area inside a building housing other occupancies.

NG.1.4.2.2.1 Signs inside buildings should be sized to be legible at the furthest straight-line distance on approach to the room or area. Where the ESS is located in a long hallway, installers should consider installing at least one side perpendicular to the room entrance.

NG.1.4.3 Electrical Hazards.

NG.1.4.3.1 Electrical warning signage should be provided in accordance with *NFPA 70*.

NG.1.4.3.2 Signs should be provided on the building or in the installation area indicating the location of main disconnects from the electrical supply or grid. In the event of a fire, personnel or first responders might need to access the main electrical disconnect.

NG.1.4.3.3 Where emergency ventilation is used to mitigate an explosion hazard, the disconnect for the ventilation system should be clearly marked to notify personnel or first responders to not disconnect the power supply to the ventilation system during an evolving incident.

NG.1.4.4 Thermal Runaway Hazards.

NG.1.4.4.1 There are hazards associated with the gaseous products of thermal runaway, including the potential for fire, explosion, and inhalation or dermal toxicity (see G.2). The manufacturers' SDS should be used to develop signs and placards to inform personnel and first responders as part of an effective emergency response plan.

NG.1.4.4.2 Many manufacturers have developed hazard communication materials using the GHS, including pictograms that are generally accepted international warning signs. Installers and operators should consider using the manufacturers' pictograms to develop warning signs or placards.

NG.2 Fundamentals of Hazards Associated with LIB-Based ESS.

Battery energy storage systems (ESS) that are designed with sufficient safety protections and are installed, operated, and maintained in a manner that maintains the system safety can be operated without incident as evidenced by the systems currently operating safely in the field. The safety controls and hazard mitigation approach need to consider the inherent hazards associated with these systems, which can vary depending on the battery technology.

NG.2.1 Hazards General. The hazards that need to be addressed for ESS are fire and explosion hazards, chemical hazards, electrical hazards, stranded or stored energy hazards, and physical hazards. These hazards can vary by technology but can also vary under normal operating conditions compared with emergency and abnormal conditions.

NG.2.2 Fire and Explosion Hazards.

NG.2.2.1 The potential for fire hazards can be evaluated through control of the elements of the fire triangle. These elements are the fuel for the fire, the oxidant, and the ignition source heat. There is no potential for fire unless there is an appropriate concentration of fuel, oxidant, and a heat source sufficient to ignite the concentration.

NG.2.2.2 Under normal operating conditions, fire and explosion hazards can be due to heat sources such as live parts that can be in contact with combustible materials during service or maintenance, or to ignition of combustible concentrations or ignitable fluids and solids that can occur as part of the normal operation of ESS, such as hydrogen off-gassing from batteries with aqueous electrolytes that are open to the atmosphere.

NG.2.2.3 Under abnormal operating conditions, fires can be the direct result of the following:

- (1) Flammable concentrations can develop due to overheating and venting of flammable gases. A fire or explosion will occur if concentrations of vented gases such as hydrogen and hydrocarbons are sufficient to create combustible/flammable concentrations in the presence of hot

surfaces, live electrical equipment, or other sources of ignition. All batteries, with the exception of hermetically sealed types such as sodium beta, have means to relieve internal pressure when overheated to prevent explosions of the battery cell from overpressurization

- (2) Short circuits and thermal runaway can cause overheating of electrical parts or ignitable plastic casings. In the case of thermal runaway, this can lead to a cascade failure of several modules or racks, and extensive fire damage.
- (3) An oxidizer in an ESS will increase the intensity of a fire of other materials.

N G.2.3 Chemical Hazards.

N G.2.3.1 Chemical hazards are categorized in accordance with OSHA/NIOSH hazardous materials limits for normal operation of the ESS and NFPA 704 for acute exposure, such as during a fire or other emergency incident.

N G.2.3.2 Under normal operating conditions, workers can be exposed to hazardous materials during maintenance, repair, and replacement of batteries, racks, or entire systems. OSHA and NIOSH have guidelines on exposures to hazardous materials, including limits for workers that have the potential for exposure during normal operation and maintenance.

N G.2.3.3 The following similar hazards are present during abnormal operation, but should be considered more likely as a result of upset or damage:

- (1) *Corrosive spills:* A liquid with a pH ≤ 2 or ≥ 11.5 is considered corrosive and hazard level 3 and can cause serious or permanent eye injury for someone who comes in direct contact with it per Table B.1 in NFPA 704. With some systems that contain corrosive liquids, there can be the possibility of leaks or spills from the system under emergency/abnormal conditions.
- (2) *Toxic liquid exposure:* There are different levels of toxicity from vapors generated under emergency conditions such as fires and hazardous toxic liquid leaks and spills. NFPA and OSHA provide extensive guidance on classifying the hazards associated with toxic liquids and vapors.
- (3) *Water-reactive material exposure:* Water-reactive materials in ESS could be exposed under abnormal conditions, resulting in a violent reaction with the moisture in the air.
- (4) *Toxic gas exposure:* Toxic gases can be released during abnormal operation or following damage to an ESS. OSHA and NFPA 704 contain guidelines for classification of these hazards.

N G.2.4 Electrical Hazards.

N G.2.4.1 Electrical hazards for persons working with ESS where they might come in contact with energized parts greater than 50 V and exposed to arcing of electric energy with an incident energy level of 1.2 cal/cm^2 (5 J/cm^2) (i.e., potential to cause second-degree burns on skin) are electrical shock and arc flash as identified in NFPA 70E.

N G.2.4.2 The term *stranded* or *stored energy* refers to unquantified hazardous levels of electrical energy that can be contained in all or part of an ESS, including one that has been damaged or thought to be discharged and that represents a hazard to persons in contact with the system who are unaware of the hazardous energy. Since this hazard represents a potential unquantified electrical hazard, the allowed levels will be different depending on whether it pertains to normal conditions for repair and replacement by trained workers or for emergency

responders dealing with damaged ESS that can still contain hazardous energy.

N G.2.4.3 The following electrical hazards can occur during normal operating conditions:

- (1) *Electrical shock:* ESS with voltages above 50 V (per NFPA 70E limits for electrical shock) can pose hazards if personnel come in contact with live parts during operation and servicing of the systems. It is necessary that appropriate labeling, safe work procedures, and personal protective equipment (PPE) are utilized by workers when servicing these systems.
- (2) *Arc flash:* ESS that have an incident energy level greater than 1.2 cal/cm^2 (5 J/cm^2) should have the arc flash boundaries calculated and identified through markings. Safe work procedures and PPE should be utilized to prevent worker injury from arc flash during normal operation and servicing.
- (3) *Stranded (stored) energy hazards:* An example of a stranded energy hazard is worker exposure to ESS that are not discharged sufficiently or ESS that are damaged, resulting in the potential for electric shock and arc flash hazards. For normal operating conditions, sites housing commercial and industrial-battery ESS should maintain onsite instructions for isolation of hazardous voltage and energy for maintenance and for discharging batteries for safe replacement and disposal. Residential and smaller commercial systems should have information provided and access to trained technicians to perform these duties to ensure that stranded energy do not represent a hazard under normal operating conditions.

N G.2.4.4 The following electrical hazards under abnormal operating conditions are similar, but could be particularly challenging for first responders:

- (1) *Electrical shock:* First responders might not have the training and protective equipment that trained electrical workers have and are therefore at greater risk of electrical shock under emergency conditions. In such emergencies, emergency responders could be exposed to live parts that have been exposed as a result of abnormal conditions, and these live parts could be in contact with conductive fluids such as water. Facility operators should work with local first responders to familiarize them with the layout, define standoff distance, and identify type and angle of water spray. The emergency operations plan required by Chapter 4 includes a section on safe shutdown, de-energization, and isolation of equipment or systems during emergency conditions.
- (2) *Shock, arc flash, and arc blast hazards:* First responders are generally not provided with training and PPE appropriate for arc flash, and arc blast hazards. The emergency operations plan should address these hazards and provide first responders with exclusion zones or similar guidance to eliminate exposure to areas where arcing might occur.

N G.2.5 Physical Hazards.

N G.2.5.1 Physical hazards are hazards to persons that can occur from contact with parts having sufficient kinetic energy, parts that have hazardous thermal characteristics that can cause burns, or parts that contain fluids at hazardous pressure levels with either insufficient structural integrity to safely contain the fluids or the ability to safely relieve the pressure.

N G.2.5.2 Physical hazards under normal operation can include the following:

- (1) *Burn hazards:* For electrochemical ESS, the potential exists for burn hazards to workers in contact with some technologies during normal operation and repair if workers are not properly thermally insulated by PPE.
- (2) *Pressurized hazards:* Parts containing pressurized fluids, including compressed gasses.
- (3) *Parts with kinetic energy:* Moving parts of ESS, such as flywheels or integral fans, should be properly guarded to prevent personnel injury.

N G.2.5.3 Some examples of physical hazards under abnormal operating conditions include the following:

- (1) Overpressurization due to overheating of contents, which can result in a physical hazard. This could present a hazard to first responders dealing with damaged ESS. This can occur due to overheating of equipment and devices that do not have pressure relief devices, or where flammable gases generated during thermal runaway experience delayed ignition.
- (2) Potential hot parts
- (3) Exposed parts with hazardous kinetic energy sufficient to cause bodily harm for persons coming in contact with them, such as exposed fan blades or flywheels

N G.2.6 Lithium-Ion Battery Hazards. The term *lithium-ion battery* refers to a battery where the negative electrode (i.e., anode) and positive electrode (i.e., cathode) materials serve as a host for the lithium ion (Li+). Lithium ions move from the anode to the cathode during discharge and are intercalated into (i.e., inserted into voids in the crystallographic structure of) the cathode. The ions reverse direction during charging. Since lithium ions are intercalated into host materials during charge or discharge, there is no free lithium metal within a lithium-ion cell and thus, even if a cell does ignite due to external flame impingement or an internal fault, metal fire suppression techniques are not appropriate for controlling lithium-ion fire.

N G.2.6.1 Hazard considerations for Li-ion batteries under normal operating conditions are as follows:

- (1) *Fire hazards:* There can be the potential for fire hazards if there are latent defects within the cells or design issues with the controls that prevent thermal runaway of the cells. Systems need to be evaluated for their ability to prevent propagation due to these defects.
- (2) *Chemical hazards:* Not applicable.
- (3) *Electrical hazards:* There are electrical hazards associated with routine maintenance of these batteries if they are at hazardous voltage and energy levels.
- (4) *Stranded or stored energy hazards:* There can be the potential for stranded or stored energy hazards during maintenance if the batteries cannot be isolated for maintenance or replacement.
- (5) *Physical hazards:* Not applicable.

N G.2.6.2 Hazard considerations for Li-ion batteries under emergency/abnormal conditions are as follows:

- (1) *Fire hazards:* There can be the potential for thermal runaway if the batteries are not maintained at appropriate operating parameters as a result of abnormal conditions. Also, there might be fire hazards due to short-circuiting abnormal conditions.

- (2) *Chemical hazards:* There can be the potential for off-gassing of hazardous vapors under abnormal conditions depending on the size of the cells and the level of failure.
- (3) *Electrical hazards:* Electrical hazards might be present under abnormal conditions if the system is at hazardous voltage and energy levels.
- (4) *Stranded or stored energy hazards:* There can be the potential for stranded energy hazards if the batteries are exposed to abnormal conditions. Damaged batteries might contain stored energy that can be a hazard during disposal if care is not taken.
- (5) *Physical hazards:* Depending on the design of the system, the potential exists for physical hazards under abnormal conditions if accessible parts are overheating or if there is exposure to moving hazardous parts such as fans where guards might be missing.

N G.2.7 Other (Reserved).

N G.3 Hazards and Risks Posed by ESS with Hazard Mitigation Analysis (HMA) and Fire Risk Assessment (FRA).

N G.3.1 General.

N G.3.1.1 The risk assessment design process should be directed by parties experienced in fire protection engineering and in energy storage risk assessment and plant operation of the type of, or similar to the, plant under consideration.

N G.3.1.2 The creation of the assessment should be initiated as early in the design process as practical to ensure that the fire prevention, fire protection, and explosion prevention recommendations as described in this document have been evaluated in view of the project-specific consideration regarding design, layout, and anticipated operating requirements.

N G.3.1.3 Applicable process safety management (PSM) techniques should be considered.

N G.3.1.4 The purpose of the HMA is to provide a record of the decision-making process in determining the fire prevention, fire protection, and explosion prevention for appropriate hazards.

N G.3.1.5 The HMA should be a living document that continues to evolve, as the plant design is refined, and it should be maintained and revised for the life of the plant. The HMA is key to the management of change process.

N G.3.2 Stakeholders.

N G.3.2.1 Stakeholders with an interest in the scope and applicability of the fire protection design should be identified early in the process.

N G.3.2.2 Stakeholders should establish goals and objectives and evaluate whether the requirements of NFPA 855 are adequate to meet those goals and objectives. The criteria for acceptability of the level of fire and explosion protection should consider the perspective of the various stakeholders.

N G.3.3 Inputs to the HMA Process.

N G.3.3.1 General Inputs. In addition to the guidelines in this annex, the following should be reviewed for applicability:

- (1) Codes, including the following:
 - (a) State and local building codes
 - (b) State and local fire codes

- (2) Standards, including the following:
 - (a) Industry standards
 - (b) Utility company standards
 - (c) Insurance requirements
 - (d) Applicable NFPA documents (see Chapter 2)
- (3) Regulations, including the following:
 - (a) Environmental
 - (b) OSHA
- (4) Other references, including the following:
 - (a) *SFPE Handbook of Fire Protection Engineering* and journals
 - (b) *SFPE Engineering Guide to Fire Risk Assessment* (Chapters 14 and 15)
 - (c) Best practices: EEL, EPRI, IEEE
 - (d) *NFPA Fire Protection Handbook*
 - (e) NFPA 805 (performance-based criteria in Chapter 4)
 - (f) NFPA 550
 - (g) NFPA 551
- (5) Design documents
- (6) Stakeholder inputs

N G.3.3.2 Project-Specific Inputs. Each facility has its own special conditions that impact the nature of the installation. Many of the specific criteria herein might need modification, due to the consideration of all project-specific factors involved. The project-specific inputs utilized in the HMA process include, but are not limited to, the following:

- (1) Energy capacity and power
- (2) Personnel/life presence levels as follows:
 - (a) Unattended/remote
 - (b) Manned but unoccupied
 - (c) Unoccupied but in populated area
 - (d) Occupied space
 - (e) Ambulatory space
- (3) Energy types and volatility
- (4) Plant layout and geographic (i.e., remote) location
- (5) Equipment availability/redundancy
- (6) Availability of water supply
- (7) Capability of emergency responders
- (8) Storage configuration (e.g., short term and long term)
- (9) Historical loss information/lessons learned/fire reports
- (10) Additional environmental considerations

N G.3.4 Fire and Explosion Protection Design Basis Process.

N G.3.4.1 Stakeholders should establish goals and objectives and evaluate whether the requirements of NFPA 855 are adequate to meet those goals and objectives. The criteria for acceptability of the level of fire and explosion protection should consider the perspective of the various stakeholders.

N G.3.4.2 The general arrangement and plant layout should be provided to clearly reflect the separation of hazards. If the layout is not acceptable, an additional fire and explosion risk evaluation should be developed to ensure objectives are met, and then return to the review process.

N G.3.4.3 Each hazard/area should be reviewed against the goals and objectives and NFPA 855. If the hazards control is not acceptable, then a fire risk evaluation should be developed to ensure objectives are met, and then return to the review process. NFPA 550 and NFPA 551 should be utilized for evaluation techniques. EPRI provides a good safety analysis base on bowtie review of failure analysis.

N G.3.4.4 An HMA should be developed.

N G.3.4.5 As the project evolves, the HMA should be reviewed and updated as necessary to incorporate changes and revisions (see Figure G.3.4.5).

N G.3.5 Fire Protection HMA or FRA (Deliverables).

N G.3.5.1 The scope of the HMA should be to establish the fire and explosion protection design criteria for the facility. The development of the HMA should be an iterative process. The HMA should be revised as the design progresses and technical design aspects are selected and finalized, and based on dialogue among the stakeholders. The HMA should outline the protection/prevention design basis for achieving the fire hazard control objectives agreed upon by the stakeholders, including the following:

- (1) Identify assumptions and threats (including G.3.3.2)
- (2) Identify source documents
- (3) Identify each hazard and consequence, identify which prevention/protection features are to be provided or omitted, and summarize the decision-making process
- (4) Identify where operational and administrative controls are assumed to be in place to mitigate the need for fire protection features

See Figure G.3.5.1 for an HMA process flow diagram.

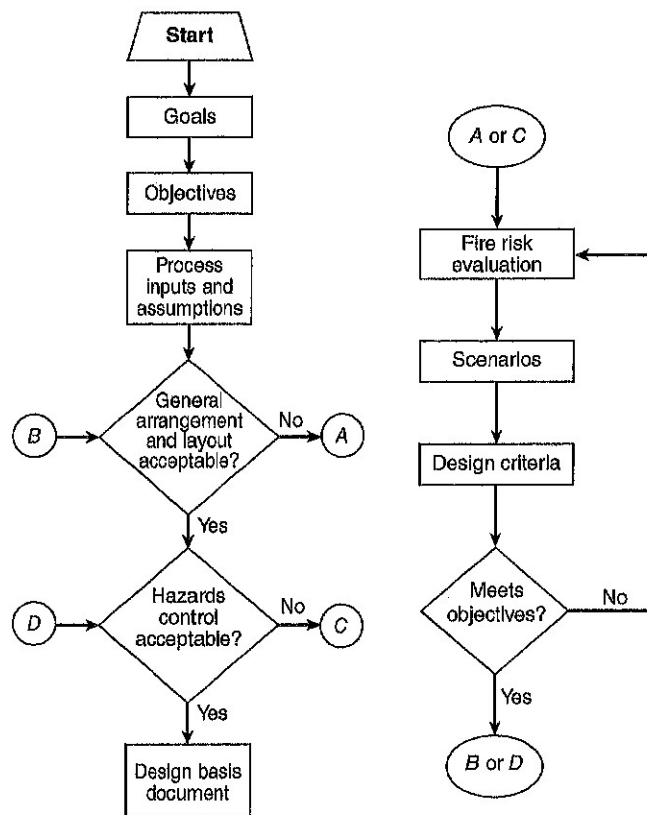

FIGURE G.3.4.5 Fire Protection Design Basis Process Flow Chart.

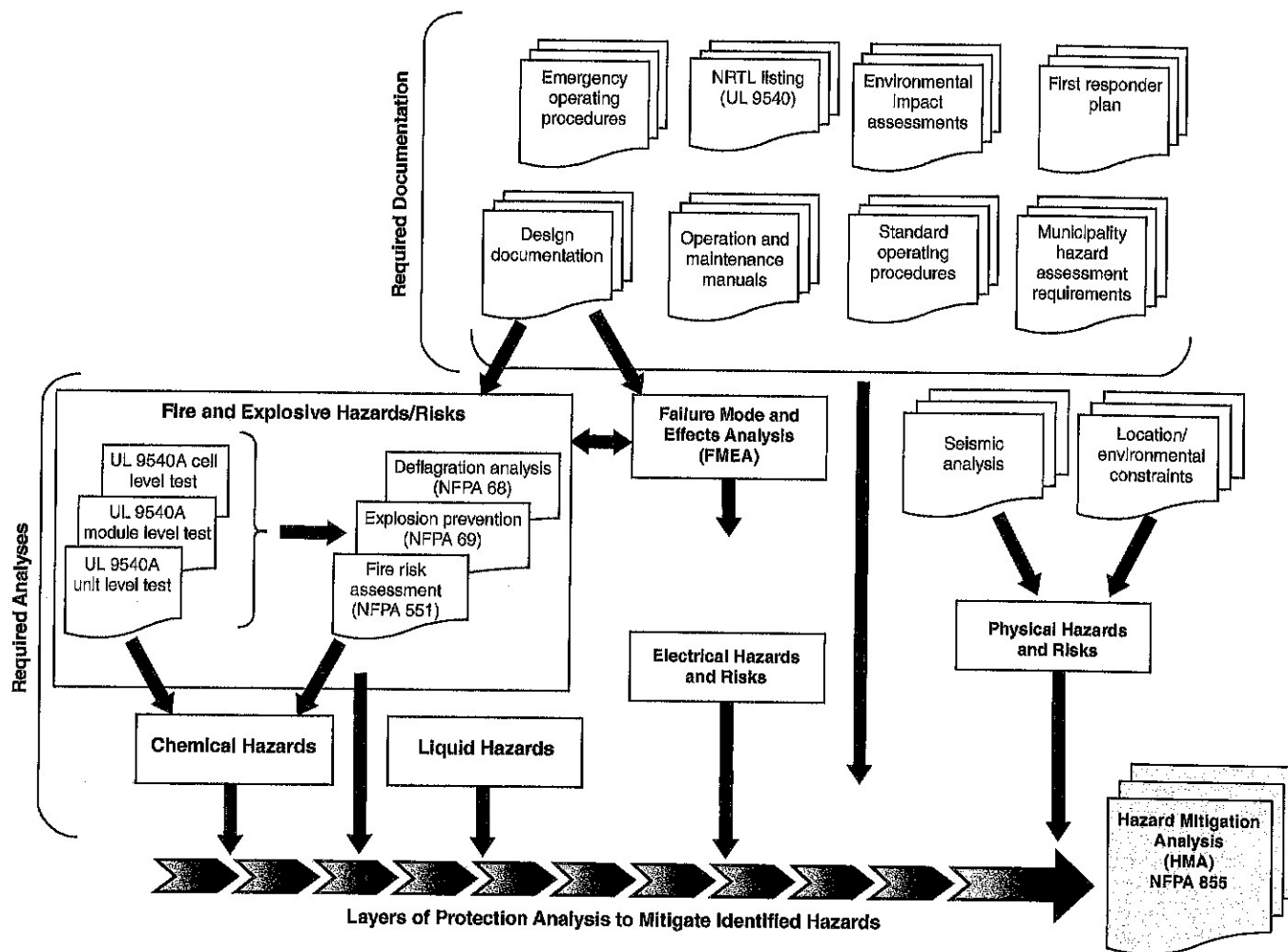

FIGURE G.3.5.1 Hazard Mitigation Analysis (HMA) Process Flow Diagram.

G.3.5.2 During the various stages of the design development and the development of the HMA/FRA, assumptions should be made when inadequate or insufficient information is available. These assumptions should be clearly identified and documented in accordance with Section G.3.5. As additional information becomes available, the assumptions should be updated or replaced with actual design information and the HMA should be amended as necessary to reflect the more definitive information.

G.3.5.3 The process identified in G.3.5.1 and G.3.5.2 should be documented. The format of the document is a statement on general fire and explosion protection philosophy for the facility and a comparison of the facility fire protection features to the guidelines in the design chapters; for example, protection of thermal runaway addressing suppression and mitigation measures.

G.3.6 Common HMA and FRA Concepts Related to ESS. To ease the process of developing and reviewing HMAs or FRAs as they relate to energy storage, this section provides examples of threats, hazards, and consequences posed by energy storage systems; how they might fit into a hazard mitigation assessment; and then parallels between the hazard mitigation assessment and fire risk assessment. As a reference, NFPA 550 was used to

provide clear comparisons between certain types of hazard mitigation assessments, namely the bowtie model and fire safety/risk concepts. While some bowtie models cover dozens of threats across multiple models, these threats can be broken down into a smaller number of general hazard categories. For energy storage, one proposed set of hazard categories includes the following:

- (1) Thermal failures (HVAC or noncell related)
- (2) Controls failures
- (3) Cell internal failures
- (4) External/environmental risks
- (5) Electrical risks

Within these hazard categories, multiple threats exist, which would result in cells catching fire and, ultimately, that fire propagating, or posing the risk of propagating, throughout the whole system. Between these threats and such hazard events occurring, barriers exist that can stop the failure from occurring, minimize its severity, or contain its outcome such that it is unable to propagate. Should these barriers fail to do so, the event would then result in a propagating failure, leading to some consequence that could range from a fire involving some number of cells to a container or system wide, catastrophic conflagration. While the failure mode and effects analysis

(FMEA) called for in UL 1973 and UL 9540 look at the barriers in place to prevent these types of events within the ESS itself, an HMA or FRA looks holistically at the system and includes environmental and as-built components and considerations not included at the product level.

Alternatively, the Fire Safety Concept Tree, which lays out fire safety objectives, is broken into two categories, Prevent Fire Ignition and Manage Fire Impact; which are nearly direct parallels to mitigating threats and managing consequences in the bowtie model.

Each of the subconcepts beneath Prevent Fire Ignition and Manage Fire Impact themselves have further subcategories, and it is at this level and lower where direct parallels to hazard mitigation assessments, and ultimately the physical hardware of a battery system, can be explained to the lay stakeholder. Figure G.3.6(a), Figure G.3.6(b), and Figure G.3.6(c), are examples of flowcharts for fire safety from objectives through ignition and propagation.

As an example, Prevent Fire Ignition is broken into three subcategories: Control heat-energy sources, Control source-fuel interactions, and Control fuel. These categories themselves are broken into their own subcategories. It is these subcategories that begin to align with aspects of the HMA as well as with physical components of the system.

To conclude the example, control heat-energy source(s), as shown in Figure G.3.6(b), can be thought of as preventing thermal runaway or failure. To do this, one can control the rate of heat-energy release or eliminate the heat-energy source. As the flammability of lithium-ion cells is a function of their hydrocarbon electrolyte and the ability of the cells, either electrically or electrochemically to ignite that fuel, it is not possible to make the battery completely nonflammable, therefore, one must either use controls to prevent the battery from reaching a state of failure and must build the battery such that it is not inherently unstable and prone to this condition on its own.

As a result, preventing thermal runaway at the cell level can be split between controls [i.e., eliminate heat-energy source(s)] and cell quality (i.e., control rate of heat-energy release). While these categories themselves can be evaluated by qualified experts, insight into their risk and effectiveness can be evaluated initially by a number of product standards. For controls, UL 1973 and UL 9540 evaluate the effectiveness of many of the controls designed to prevent thermal runaway, while an in-depth HMA can also evaluate the effectiveness of those barriers. An example of these barriers in a hazard mitigation model is shown in Figure G.3.6(d).

In Figure G.3.6(d), cell quality control and BMS control, along with three other barriers, stand between an internal cell fault and a propagating fire through the system. These other barriers, passive cell protections, active cell protections, and cell thermal abuse tolerance, might also tie back to other aspects of the fire safety concepts tree. In this case, active mitigation, equivalent to active cell protections in the bowtie HMA, can be found under design features, itself a subcategory of prevent propagation in the model. These barriers are thus related, with some liberties, to provide separation and provide barrier in control heat-energy source transport under the concept tree. As these categories are rather broad, and themselves not necessarily relevant to energy storage, one must look at their role and their parent category, control heat-energy source transport. In considering a failing cell, and its tremen-

dous heat output, one should consider design aspects, both active or passive, which will divert this heat away, preventing further spread to adjacent cells and modules. In a more traditional fire assessment, minimizing this heat transfer is easily accomplished by creating spacing or placing a physical barrier to minimize heat transfer, but the complex nature of ESS makes this more difficult, and while placing literal fire walls (a passive approach), can help slow convective heat transfer (or even conductive), it could also allow for the buildup of explosive gases or direct the heat to other, unanticipated locations within the system. As a result, fire management designs in ESS might be more complex, involving active and passive ventilation systems, passive safety materials such as phase change or intumescent materials, or other design features not yet envisioned.

Controlling heat transfer is self-explanatory, and while the nature of lithium-ion battery fires is unique, made up of a combination of behaviors not typically observed by the fire service, each of these risks or behaviors is itself not unique. As such, UL 9540A should lend the data necessary for identifying other conduction, convection, and radiation risks and mitigating these risks. These categories, themselves while not directly addressed in the bowtie HMA, could easily be included in passive cell protections, as well as module and system passive protections used for dealing with other risks. [See Figure G.3.6(e).]

N G.4 Known Failure Modes and Their Associated Consequences and Mitigation Approaches (Bowtie Analysis).

N G.4.1 Bowtie and Hazard Mitigation Analysis Overview. Bowtie modeling is a common, industry-accepted risk and hazard mitigation analysis tool used in the maritime, oil and gas, and utility industries because it provides a clear graphical representation of the risks and protections of large, purpose-built ESS structures in traditionally difficult markets.

The strength of the bowtie approach comes from its visual nature, which forgoes complex, numerical tables for threat pathways in favor of illustrating a single hazard event or consequence and all the barriers in place to stop it. On the left side are the threats, which are failures, events, or other actions, which all result in a single, common hazard event in the center. For an ESS system, many of these threats parallel the hazards addressed by the fire code, such as unexpected thermal runaway.

The goal is to capture an entire analysis in a single model; therefore, some of the risks requiring assessment are actually consequences of the failures. For the model to be complete, the central hazard event is defined as a single-cell failure that begins to propagate through the system, rather than simply the failure of a single cell. As a result, the threats on the left are events, actions, or modes that could result in a single cell not just failing, but failing and beginning to propagate through the system in a manner which can cause more severe consequences.

As all threats and consequences tie into a single hazard event, the shape of the model resembles a bow tie. The length of the pathway on either side is dependent on the number of barriers that exist to prevent that threat from reaching the hazard event or the hazard event from devolving into the full consequence.

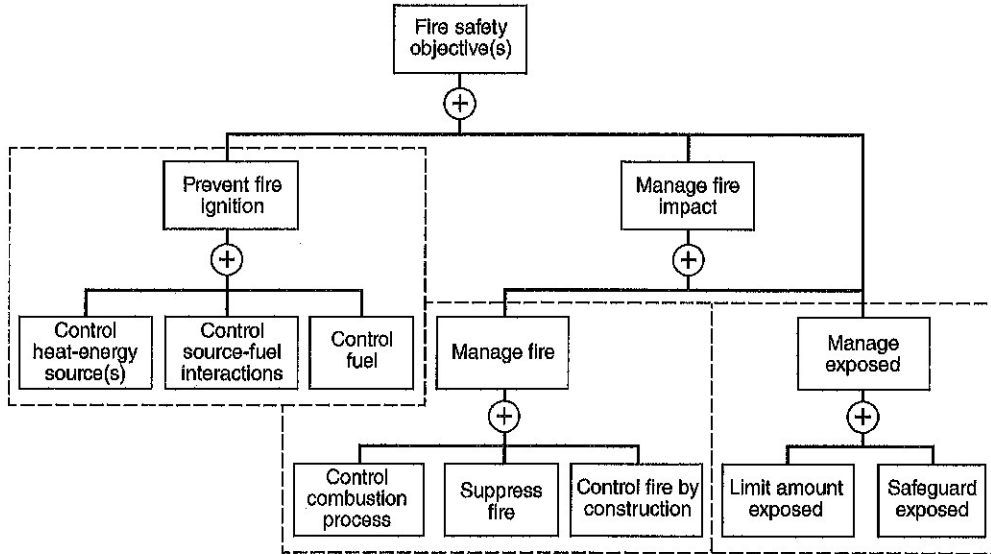

FIGURE G.3.6(a) Example Fire Safety Objectives Flow Chart.

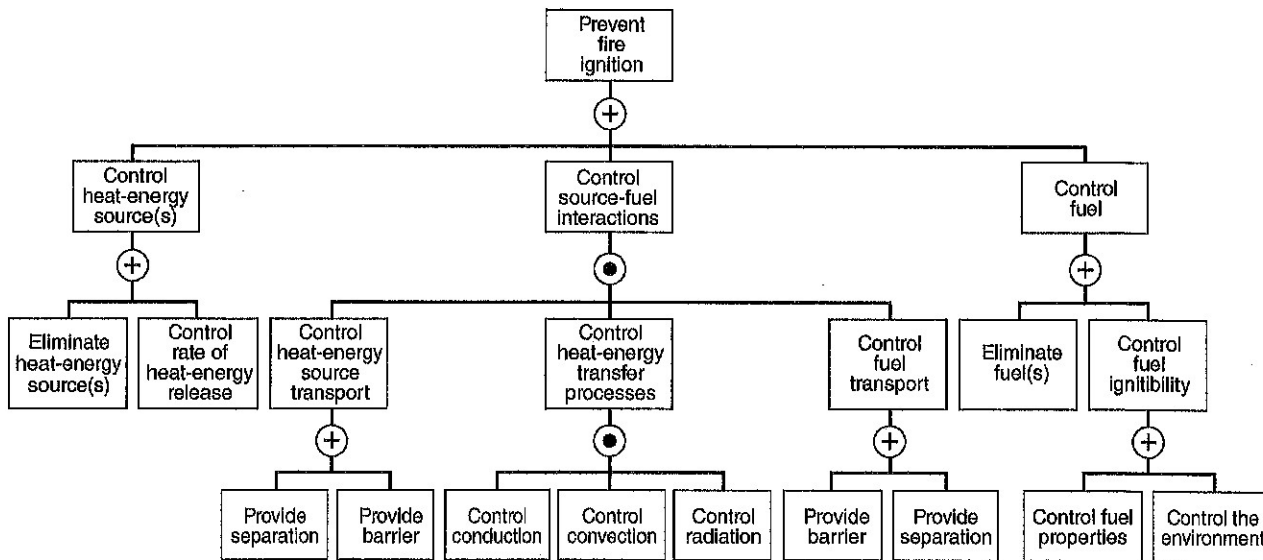

FIGURE G.3.6(b) Example Prevention of Fire Ignition Flow Chart.

G.4.2 Threats. Threats identified in a bowtie analysis are not generally catastrophic failures, but rather the smaller, precursor events that can lead to catastrophic consequences. As most catastrophic failures are not the result of everything going as expected, the threat pathway of the model allows plausible and probable events to be assessed by evaluating the strength and category of the barriers designed to prevent those events from resulting in failure. In the case of energy storage systems, many of these barriers include active electrical monitoring and controls, passive electrical safeties, and redundant failure detection. Should these systems fail to detect the failure, shutting down the system, or otherwise prevent thermal runaway from occurring, there are physical design elements that can prevent that fire from spreading. Should those elements fail as well, the threat pathway arrives at the central hazard event: a propagating fire that will escalate unless mitigated by barriers on the

consequence side. Without mitigation, the central hazard event will almost assuredly result in property damage and long-term system shutdown. As such, it is critical the consequence barriers be evaluated in an intellectually honest manner such that the true strengths and weaknesses of the system are understood. This provides operators with the opportunity to identify and correct weaknesses before becoming problematic during a failure.

G.4.2.1 Individual Pathways.

G.4.2.1.1 Single-Cell Thermal Runaway. One of the more straightforward threats, this pathway details what barriers exist to keep a single-cell thermal runaway from occurring—if electrically initiated—and if it occurs, what barriers can prevent it from propagating to neighboring cells.

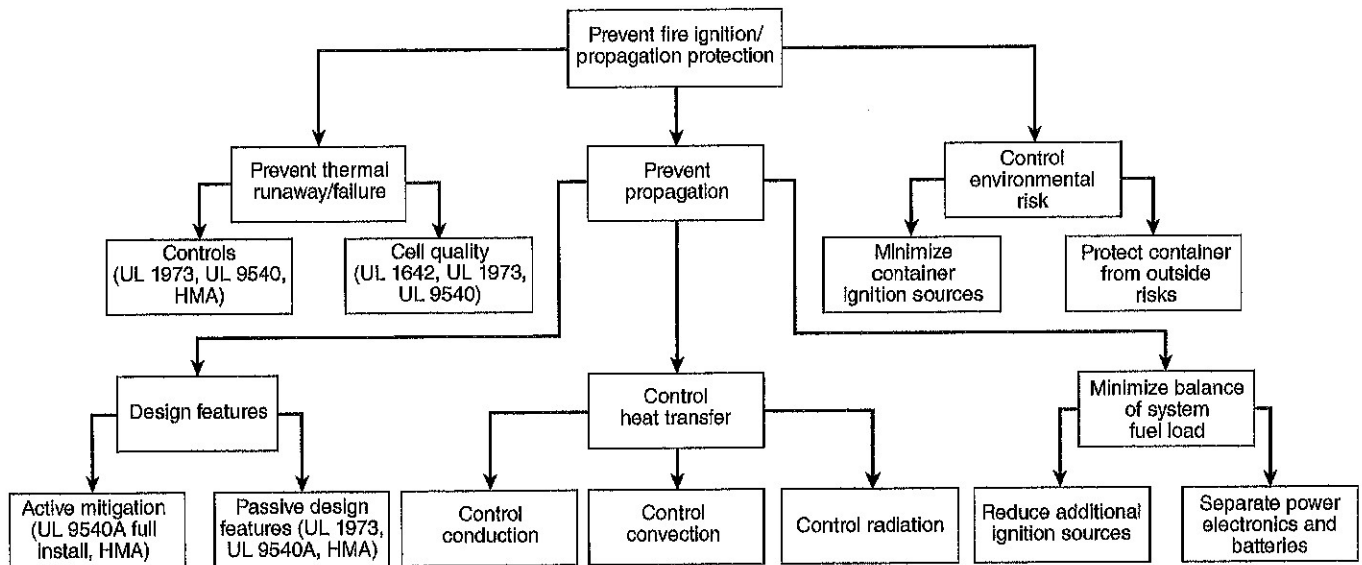

FIGURE G.3.6(c) Example Fire Ignition and Propagation Protection Flow Chart.

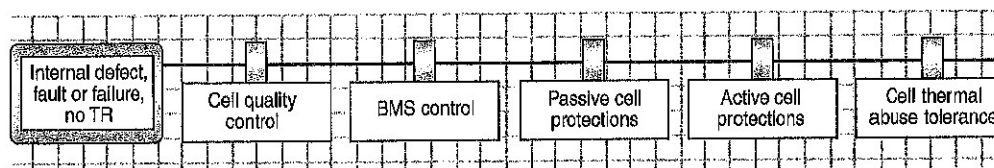

FIGURE G.3.6(d) HMA Bowtie Model.

N G.4.2.1.2 Multicell Thermal Runaway Causes. Causes of multicell thermal runaway include the following:

- (1) Internal defect or failure that doesn't result in thermal runaway
- (2) BMS failure, ESMS failure, inverter failure, sensor failure
- (3) Site control, balance of plant, balance of system, programmable logic controller (PLC) failure
- (4) Ground fault, short-circuit hazardous voltage condition

N G.4.2.2 Individual Barriers.

N G.4.2.2.1 Cell-Level Failures and Protections.

N G.4.2.2.1.1 Passive Cell Protections. System design, passive materials, or other design elements incorporated to passively protect neighboring cells from localized cell failure. This also includes the likelihood of cell-to-cell propagation based on system design.

N G.4.2.2.1.2 Active Cell Protection. Active cell protections that can mitigate thermal runaway such as module fans, liquid cooling systems, module scale suppression systems, or other mitigation measures.

N G.4.2.2.1.3 Cell Thermal Abuse Tolerance. Ability of the cells to withstand thermal abuse without going into failure themselves.

N G.4.2.2.1.4 Cell Quality Control. Overall quality of the cell such that internal defects are minimized and cells maintain rigidity and shape during operations. Also includes tight tolerances with respect to degradation and new capacity.

N G.4.2.2.1.5 Cell Electrical Abuse Tolerance. Ability of the cell to withstand electrical abuse such as overcharge, overdischarge, high currents, or other adverse electrical abuse.

N G.4.2.3 Passive Physical and Electrical Protections.

N G.4.2.3.1 Passive Circuit Protection and Design. Current interrupt devices, breakers, fuses, or other passive elements that can open the circuit in the case of failure and general resilience of design to withstand adverse electrical conditions.

N G.4.2.3.2 System Shutdown/Disconnect. Ability of system to actively shut itself down or disconnect itself. This is the aggregate of the battery management system (BMS) or inverter's shutdown ability, as well as physical disconnects and the BMS controller's ability to shut down.

N G.4.2.4 Active Monitoring, Controls and Electrical Protections.

N G.4.2.4.1 System Shutdown/Disconnect. Ability of the system to actively shut itself down or disconnect itself. This is the aggregate of the BMS or inverter's shutdown ability, as well as physical disconnects and the BMS controller's ability to shut down.

N G.4.2.4.2 Redundant Failure Detection/System Intelligence. Ability of system to determine a sensor has failed, to shut down safely without that sensor, or operate safely indefinitely without that sensor. This can include check sums, additional sensors, or the ability to pull data from other sensors.

N G.4.2.4.3 BMS Control. Includes monitoring and shutdown/isolation capabilities of the affected BMS/module.

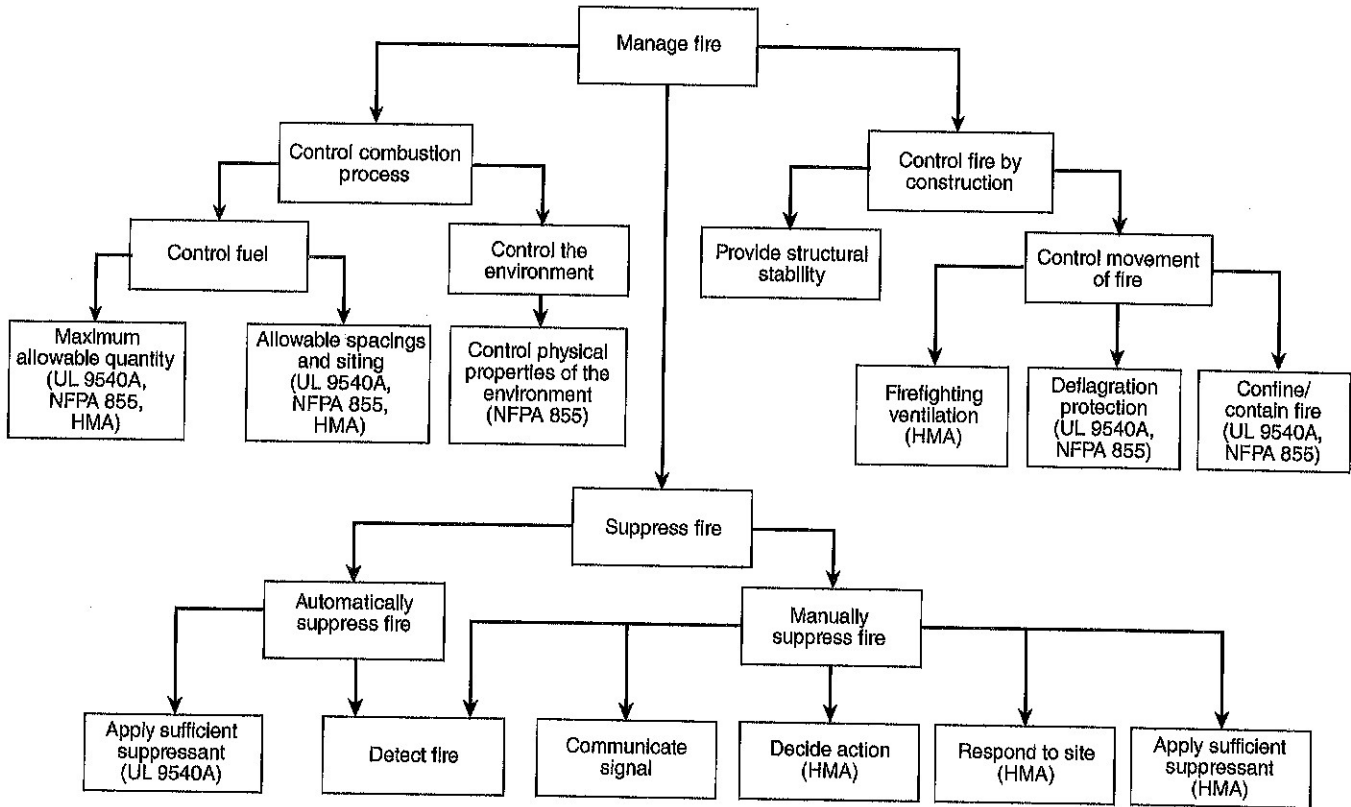

FIGURE G.3.6(e) Example Manage Fire Flow Chart.

N G.4.2.4.4 Voltage Monitoring. The overall effectiveness of the voltage monitoring scheme of the system.

N G.4.2.4.5 Inverter/PCS Controls. Includes monitoring and shutdown/isolation capabilities.

N G.4.2.4.6 System Electrical Abuse Tolerance. The ability of the overall system collectively to withstand adverse electrical abuse, such as overcharge or dead shorts, without failure.

N G.4.3 Consequences.

N G.4.3.1 Individual Pathways.

N G.4.3.1.1 Individual Barriers.

N G.4.3.1.1.1 Fire, Smoke, Heat, and Failure Detection. The system used in this example will include early warning smoke detection and early intervention off-gas sensors in the ESS envelope. This category can also include gas detection technologies to identify battery off-gas in the environment outside of the ESS.

N G.4.3.1.1.2 Situational Awareness. Knowledge of failure condition for active mitigation and response management.

N G.4.3.1.1.3 Gas Phase Suppression System. A gaseous special protection system, such as inert gas or aerosolized gas-based agent designed for fire suppression is included in the sample analysis.

N G.4.3.1.1.4 Exhaust Ventilation. Effectiveness of exhaust ventilation to remove battery off-gas, heat, and smoke, which can result in adverse atmospheric conditions.

N G.4.3.1.1.5 Water-Based Suppression System. Water-based suppression systems include sprinklers, sprayers, deluge systems, or water mist systems designed to suppress fire.

N G.4.3.1.1.6 Emergency Action Plan/First Responders. The system operator's plan to handle any and all emergency events—separate from local/public fire service response.

N G.4.3.1.1.7 Fire Service Response. Fire department response, including active firefighting.

N G.4.3.1.1.8 Thermal Isolation/Cascading Protection. Thermal protections inside the battery compartment to limit module fire/thermal exposure.

N G.4.3.1.1.9 Facility Design and Siting. Placement of the facility such that adverse environmental effects such as flooding, vehicle impact, and fire impingement are mitigated or avoided. Likewise, placement such that adverse effects from the system to exposures are limited.

N G.4.3.2 Other Pathways. (Reserved)

N G.5 Application of LIB-Based ESS and How Location Within a Building Impacts the Hazard Analysis. (Reserved)

N G.6 Fire Protections Systems and Mitigation Strategies, Including System Goal, Water Duration, and Water Application Strategies.

N G.6.1 Suppression Technologies. Suppression systems can extinguish a fire but will not stop thermal runaway once initiated in a cell or off-gassing of damaged cells, which creates a potentially explosive environment. If gas is allowed to accumulate, a more hazardous condition can develop. There might be

times that venting is more critical than suppression. Challenges in gas detection might lead to increasing levels of combustible gas or toxic gases during suppression. Venting might be required through either a direct tie to the fire detection system or operator action. While non-water-based fire suppression has been shown to be effective at suppressing Class A, Class B, and Class C fires in ESS enclosures, both water-based and non-water-based current suppression agents might not provide the cooling needed to stop thermal runaway once begun in a cell or to prevent propagation. While water is effective at long-term cooling if directed at the affected cell(s), additional damage from water exposure might lead to extended thermal events in other cells or modules.

The current protection concepts in this standard, including size and separation, maximum rated energy, and elevation, are designed to keep a thermal runaway event from propagating from one ESS unit to another, contain a fire within a room or outdoor walk-in unit, and prevent it from compromising exposures. Even if the fire has been extinguished, the fire detection system should still be monitored in case of any subsequent reignitions. The technologies detailed in G.6.1.1 through G.6.1.6 represent those commonly used at the time of publication. It does not preclude the design or implementation of engineered or pre-engineered systems that comply with the fire and explosion test criteria provided in 9.1.5.

N G.6.1.1 Sprinklers. There are two known publicly available fire and explosion tests, equivalent to UL 9540A, supporting the use of ceiling-level sprinkler systems for the protection of LIB ESS. One test evaluated a 83 kWh system made up of lithium-iron-phosphate batteries and another evaluated a 125 kWh system made up of nickel-manganese-cobalt-oxide batteries. In both tests, protection was provided by ceiling sprinklers having a K-factor of 5.6 gpm/psi^{1/2} operating at a discharge pressure of 2 bar (29 psi) to provide a nominal discharge density of 0.3 gpm/ft². The results show that fire and explosion testing is needed to determine the following:

- (1) Ceiling sprinkler protection can prevent or delay a fire from spreading beyond the ESS rack of origin, but obstructions caused by the design of ESS system (e.g., solid-metal cabinet encompassing tightly packed battery modules) limit the ability to suppress or extinguish fire within the rack of origin.
- (2) Minimum space separation has been provided from the ESS to surrounding combustibles to limit the potential for additional fire spread, including nearby ESS racks
- (3) Minimum space separation has been provided from the ESS to surrounding noncombustible objects to limit the potential for damage
- (4) If fire does spread to an adjacent ESS rack (i.e., installed side-by-side), it does not impact the design and electrical capacity of battery components as well as the design of the ESS cabinet that houses the battery components (e.g., battery modules)
- (5) Adequate cooling of the batteries is provided to prevent reignition, which can occur after a fire appears to be extinguished. A fire watch should be present until all potentially damaged ESS equipment containing Li-ion batteries is removed from the area following a fire event.
- (6) Adequate building component rating is provided to withstand the expected intensity and duration of an ESS fire event.

The wide range of results highlight the need for fire and explosion testing to evaluate sprinkler protection for each unique ESS to ensure the expected level of protection is provided. Protection system considerations that would require a fire and explosion test include a reduction in the specified sprinkler system design density, a reduction in the minimum separation distance from nearby combustible and noncombustibles, changes in ESS cabinet, or increasing ESS electrical capacity.

N G.6.1.2 Spray Systems. (Reserved)

N G.6.1.3 Water Mist Systems. Water mist is a water spray for which the 99 percent of the total volume of liquid (Dv0.99) is distributed in droplets with a diameter smaller than 1000 microns at the minimum design operating pressure of the water mist nozzle.

N G.6.1.3.1 Different Types of Water Mist Systems. The types of water mist systems are as follows:

- (1) *High Pressure.* Water mist system where the distribution system piping is exposed to pressures of 34.5 bar (500 psi) or greater.
- (2) *Medium Pressure.* Water mist system where the distribution system piping is exposed to pressures greater than 12.1 bar (175 psi) but less than 34.5 bar (500 psi).
- (3) *Low Pressure.* Water mist system where the distribution piping is exposed to pressures of 12.1 bar (175 psi) or less.

N G.6.1.3.2 Standards. For more information on water mist systems, see NFPA 750.

N G.6.1.3.3 Fire and Explosion Test Report References for Li-Ion Battery Fire Suppression with Water Mist. For more information on fire and explosion testing for Li-ion battery fire suppression with water mist, see the following:

- (1) DNVGL Battery Safety Joint Development Project Report, "Technical Reference for Li-ion Battery Explosion Risk and Fire Suppression."
- (2) Marioff Corporation – Fire Test Summary #57/BR/AUG15, "HI-FOG® Systems for Protection of Li-ion Rooms."

N G.6.1.3.3.1 Testing. Water mist fire protection systems are performance-based systems and must be tested by means of fire and explosion testing to verify performance to achieve predefined testing objectives of fire extinguishment, fire suppression, fire control, temperature control, or exposure protection per NFPA 750.

Testing performed as part of the DNVGL Battery Safety Joint Development Project and published in the report dated January 7, 2020, included a specific water mist manufacturer's high-pressure water mist product, and gave promising insight to the effectiveness of a high-pressure water mist system on Li-ion battery fires. The data collected yielded the following results for the high-pressure water mist system tested:

- (1) Could not stop thermal runaway process in the damaged battery module
- (2) Extinguished the flames in both the front and back of the burning module
- (3) Provided long-term heat absorption
- (4) Absorbed and cooled flammable gases reducing LEL percent

- (5) Cooled down the space as a whole
- (6) Scrubbed toxic gases
- (7) System was effective with the enclosure vented or sealed
- (8) Reduced and minimized propagation to neighboring module

Currently there are no specific fire-testing protocols or guidance documents developed for water mist systems by any listing agency for the protection of battery storage systems incorporating Li-ion batteries that would result in a listed water mist system for this specific hazard. Additionally, there are no publicly available test data using water mist systems that was completed as part of the UL 9540A propagation evaluation.

Currently, FM Approvals does not have a specific fire testing protocol or guidance document developed for water mist systems for the protection of battery storage systems incorporating Li-ion batteries that would result in an FM approval for the water mist system for this specific hazard type for the water mist system's manufacturer.

N G.6.1.3.4 Design and Installation. Design and installation should be based on NFPA 750 and manufacturer-specific requirements as it pertains to LIB ESS (e.g., nozzles spacings, maximum ceiling heights, nozzle mounting orientation, min and max distance from front of Li-ion rack front face, and so on). Manufacturer requirements should be derived from a fire and explosion test of the proposed ESS arrangement and manufacturer-specific design, installation, operations, and maintenance manuals.

N G.6.1.3.5 Inspection, Testing, and Maintenance. Inspection, testing, and maintenance should be done in accordance with the requirements of the water mist system manufacturer's design, installation, and maintenance manuals; NFPA 750; or NFPA 25 with regard to the relevant servicing intervals and other servicing requirements to properly maintain the system.

N G.6.1.4 Clean Agents. Clean-agent suppression systems can extinguish a fire but will not stop thermal runaway or off-gassing if the cells are damaged, creating a potential explosive environment. Similar to a natural gas fire, if gas is allowed to accumulate, a more hazardous condition can develop. There might be times that venting is more critical than suppression. If the gas detection system continues to see increasing levels of combustible gas or toxic gases during suppression, venting might be required through either a direct tie to the gas detection system or a manual operation to begin venting. The suppression systems might not have reached their hold times yet and agent might be vented. Even if the fire has been extinguished and hold times have been met, the gas detection system should still be monitored in case of any subsequent events, including reflash due to stranded energy. Venting might be required at a later point as well.

If clean agent suppression is used as the primary fire suppression method and is not backed up by a water-based sprinkler system designed per NFPA 855 or with a fire and explosion test meeting the specifications of the sprinkler section in this annex, a fire and explosion test should be conducted using the proposed ESS arrangement with the clean-agent protection criteria proposed. Such a test should meet predefined approval criteria and also dictate the necessary hold time for the anticipated thermal runaway event.

N G.6.1.4.1 Design and Installation. Total flooding and local application gaseous agent systems should be designed based on factors including, but not limited to, the following:

- (1) Agent concentrations required for the specific combustible materials involved, including building systems and battery electrolytes, whichever are higher
- (2) Specific configuration of the equipment and enclosure
- (3) Maintaining the design concentration within the enclosure for a time to ensure that the fire is extinguished and that the enclosure temperatures of the ESS have cooled to below the autoignition temperature of combustible material present and below the enclosure temperature that can cause thermal runaway as defined in the emergency operations plan
- (4) Suppression systems' inability to cool the internal battery temperature once thermal runaway has started

Fire suppression system discharge durations should be held as long as the hazards of temperatures above the autoignition temperature and the temperature at which thermal runaway can occur. The manufacturer should be consulted for applicable ESS cooldown times. Information on fire tests that demonstrate the extinguishment time for an ESS should also be considered in determining the minimum discharge time. An extended discharge time is necessary to prevent potential fire reignition due to smoldering and heat soak. Where design concentrations cannot be maintained effectively, an alternative system should be provided.

If gas levels should continue to increase during a fire event, an operating device should be available in an approved location such that fire services can begin exhaust prior to hold time expiration if deemed necessary.

N G.6.1.5 Inerting. (Reserved)

N G.6.1.6 Aerosols. Aerosol suppression systems can extinguish a fire but will not stop thermal runaway or off-gassing if the cells are damaged, which creates a potentially explosive environment. If gas is allowed to accumulate, a more hazardous condition can develop. There might be times that venting is more critical than suppression. If the gas detection system continues to see increasing levels of combustible gas or toxic gases during suppression, venting might be required through either a direct tie to the gas detection system or a manual operation to begin venting. The suppression systems might not have reached their hold times yet and agent might be vented. Even if the fire has been extinguished and hold times have been met, the gas detection system should still be monitored in case of any subsequent events, including reflash due to stranded energy. Venting might be required at a later point as well.

EN 15276-1 and EN 15276-2 state that condensed aerosols are not to be used on fires involving the following:

- (1) Chemicals containing their own supply of oxygen (e.g., cellulose nitrate)
- (2) Mixtures containing oxidizing materials (e.g., sodium chlorate, sodium nitrate)
- (3) Chemicals capable of undergoing autothermal decomposition (e.g., some organic peroxides)
- (4) Reactive metals (e.g., sodium, potassium, magnesium, titanium, zirconium), reactive hydrides, or metal amides, some of which can react violently with the extinguishants

- (5) Oxidizing agents (e.g., nitric oxides and fluorine)
- (6) Pyrophoric materials (e.g., white phosphorous, metallo-organic compounds)

The above list is not exhaustive. Items (3) and (5) are applicable to lithium-ion batteries.

N G.6.1.6.1 Standards. For more information on aerosol systems, see the following:

- (1) NFPA 2010
- (2) NFPA 70
- (3) NFPA 72
- (4) ANSI/UL 2775, *Standard for Fixed Condensed Aerosol Extinguishing System Units*
- (5) International Code Council IFC and IBC standards

N G.6.1.6.2 Listing.

N G.6.1.6.2.1 The fire extinguishing agents addressed in this standard should be listed in the US EPA SNAP list for use as a total-flooding fire-extinguishing agent in occupied and unoccupied spaces.

N G.6.1.6.2.2 Aerosol systems and automatic aerosol units should be listed for service at ambient operating temperatures of the LIB ESS facility where they are installed.

N G.6.1.6.2.3 All aerosol systems and automatic extinguishing units should comply with ANSI/UL 2775.

N G.6.1.6.3 Design and Installation. Aerosol systems for ESS applications can be electrically operated or manually released with a fire alarm control system meeting NFPA 72 and NFPA 70 requirements. Multiple electric operated aerosol extinguishing units can be wired in series or in parallel to the fire alarm control panel and in accordance with NFPA 2010. System design should meet listing requirements, NFPA 2010, and IFC/IBC standards.

N G.6.1.6.3.1 Aerosol quantities for the protection of ESS applications should be based on the calculation methods described in NFPA 2010.

N G.6.1.6.3.2 ESS enclosure integrity and uncloseable opening aerosol leakage impact on aerosol density should be compensated in accordance with the methods and design factor calculations described in NFPA 2010.

N G.6.1.6.3.3 ESS open loop ventilation systems should be shut down or ventilation dampers closed prior to activation of the aerosol units.

N G.6.1.6.3.4 All aerosol systems and automatic extinguishing units should be installed and used to protect ESS hazards within the limitations of and in accordance with their listing or as designated by a fire and explosion fire test.

N G.6.1.6.3.5 Electrically operated aerosol systems installed for the protection of ESS systems during transit can be fitted with a battery-operated detection and aerosol control system. ESS systems in remote locations with no primary source of AC power can be fitted with a battery-operated detection and aerosol control system.

N G.6.1.6.3.6 Automatic aerosol units for ESS applications can be stand-alone extinguishing units provided the units have sufficient capacity to flood the ESS enclosure to the minimum design density for extinguishing Class A (surface), Class B, or Class C fires in accordance with the listing.

N G.6.1.6.4 Testing. If aerosol suppression is used as the primary fire suppression method and is not backed up by a water-based sprinkler system designed per the requirements of NFPA 855 or with a fire and explosion test meeting the specifications of the sprinkler section in this annex, a fire and explosion test should be conducted using the proposed ESS arrangement with the aerosol protection criteria proposed. Such a test should meet the same criteria as the sprinkler testing criteria listed and also dictate the required hold time for the anticipated thermal runaway event.

N G.6.1.6.5 Inspection, Testing, and Maintenance. Aerosol system and automatic aerosol unit inspection, testing, and maintenance requirements should comply with listing and manufacturer guidance described in the product design, installation, operation, and maintenance manual.

N G.6.2 CO₂. (Reserved)

N G.6.3 Standpipes. Current applications for water on LIB ESS are not meeting the true definition of NFPA 13, NFPA 14, or NFPA 15. These are traditionally applied on containers, enclosures, or cabinets. They are installed as a hybrid application. The intent is to provide as much water as possible as quickly as possible. A dry stand-pipe can be added with either a connected water supply, if available, or a dry fire department connection. It can be provided at an access point or first responder's station located at the entrance to the site and away from the ESS. This application is usually applied as a last resort when all other mitigation measures have failed. It can be applied as a deluge type system or a closed-head system. While deluge systems will provide a quicker application of water, a closed-head system only applies the water at the point of heat or fire. High flow ESFR heads are recommended. The closed-head system allows for a simpler piping system to connect multiple containers or enclosures on one piping network, and possible connection to the wrong fire area. This can be applied in remote areas with a lack of water supply or urban environments where water demand might be limited. See Figure G.6.3.

N G.6.4 Hybrid Systems. (Reserved)

N G.6.5 Encapsulation. (Reserved)

N G.6.6 Pre-Engineered Systems. (Reserved)

N G.6.7 Active Technologies. (Reserved)

N G.6.8 Passive Technologies. (Reserved)

N G.6.9 Physical Barriers. (Reserved)

N G.7 Fire and Flammable Gas Detection, Including the Location, Type, and Purpose for Available Technologies.

N G.7.1 General. All fire system components, devices, equipment, and system materials that are provided or required as part of a battery rack fire suppression system should be approved by the local statutory authorities and listed or approved for their intended use.

N G.7.2 Design and Installation. All battery rack assemblies should be designed and installed in accordance with the applicable codes and standards; their tested certified configuration; and within the limitations of their certifications, listing, and approvals. Arranging and installing a battery rack assembly in configurations other than its tested and certified configuration (for example, stacking of racks, back-to-back racks, and so on) should be prohibited.

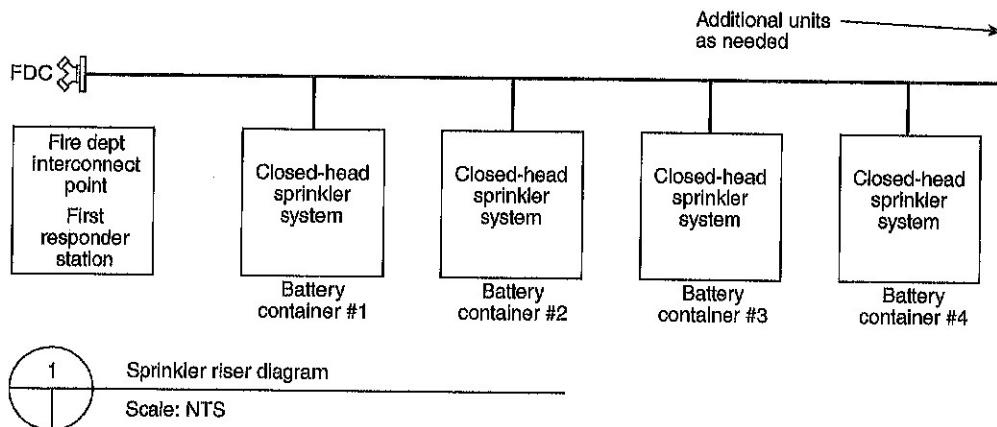

FIGURE G.6.3 Riser Diagram.

N G.7.3 Detection Systems.

N G.7.3.1 **BMS.** While not technically a detection system, a BMS can provide input into the fire system as a first-stage warning. A BMS can monitor fault conditions, abnormal voltages, and increase in heat—all potential precursors to LIB failure. The BMS, in conjunction with other detection technologies, can provide a better indication of the type of fire condition—either internal or external to the batteries.

N G.7.3.2 **Smoke Detection.** Standard spot-type smoke detection is applicable to nonbattery fires and can detect conditions that can lead to a battery failure or thermal runaway. In a battery failure, smoke is detected after thermal runaway and is not applicable to early detection of LIB failures. Smoke detection can be applied at a cabinet level for a quicker response to an LIB failure. Spot-type smoke detection can be used as an interlock for fire suppression system release.

N G.7.3.3 **Flame Detection.** Flames do not present until after an LIB has gone into thermal runaway. Flame detection can be applied internal or external to an installation. Internal application would be to the container, enclosure, or building. It would not traditionally be applied inside a cabinet. For example, it can be used to monitor a hot isle. External application would be to ESS facilities with multiple containers. It would provide a detection if internal measures failed. It can also be tied to video cameras to provide situation information to first responders of an incident.

N G.7.3.4 **Heat Detection.** Spot-type heat detection is applicable to nonbattery fires and can detect conditions that can lead to a battery failure or thermal runaway. In a battery failure, heat is detected after thermal runaway and is not applicable to early detection. Heat detection can be used as an interlock for fire suppression system release. The best use of heat detection is as a high-flow ESFR head attached to a dry stand-pipe or fire department connection to apply water to the building, area, container, or cabinet in LIB failure. Heat detection or temperature monitoring integral to the BMS can provide early indication of a battery failure prior to thermal runaway.

N G.7.3.5 **Thermal Imaging—Temperature Monitoring and Early Warning Fire Detection.** Thermal imaging might be applicable to early detection of LIB failure. With proper placement, detectors are capable of detecting small changes in temperature

associated with battery failure and early detection. It requires a line of site and might not function in a small container or cabinet. It can provide the added benefit of visual images. It can be used internal or external to the BESS. First responders can use the images to access the internal condition of the ESS.

Thermal radiation is invisible electromagnetic radiation emitted by a body or object based on its surface temperature. Thermal imaging technology (i.e., thermal radiometry) makes it possible to view, record, and alarm on the slightest temperature anomalies, making it an effective solution in monitoring batteries during normal load or test.

Fixed-mounted thermal cameras provide a predetermined field of view and continuous temperature monitoring as opposed to hand-held units requiring personnel time and potential for variation of readings and views. As a fixed unit, the camera tracks temperature and can provide graphical data over time that can be utilized in a preventative maintenance program and post-event evaluation of battery failures. Alarm relay outputs are available for monitoring by a PLC for equipment shutdown and annunciation.

Thermal radiometry hand-held cameras are commonly carried by first responders into smoke-filled buildings, as the technology can see hot spots through the smoke. Along these lines, fixed thermal radiometry cameras in an ESS building with many racks will simplify first responders' evaluation of the fire size and location, providing situational awareness and lead them directly to the fire and away from potential danger, which minimizes their time in the hazard.

Thermal radiometry cameras are available in wide to narrow field of view, various resolutions of image sensor pixel count, and software platforms. Care should be taken to ensure that the correct product is selected allowing the resolution required to accurately measure the required temperature variations at the specified distance.

Camera software can provide live or recorded video, floating-crosshair indicating pixel(s) with highest or lowest temperature, various color schemes representing temperatures, email notification of alarm, as well as configuration of multiple areas of interest with unique temperature monitoring, alarm, and graphical information within a single camera image.

N G.7.3.6 Gas Detection.

N G.7.3.6.1 Cell-Level Event. Carbon monoxide (CO) is one of the main components present for the longest period of time and is considered especially important for early stage detection.

Off-gas in the early stages of thermal runaway events will be colder than off-gas in the later stages. The early off-gas can therefore become heavier than the air, collecting at floor level. It should therefore be considered if gas detection related to room explosion risks should be applied at both levels, close to the floor and close to the ceiling. Both sensor and ASD detection technologies can provide off-gas detection in the early stages of lithium-ion battery thermal runaway events. In addition to off-gas detection, ASD detection can provide very early smoke detection.

Tests conducted in this project indicate that solely relying on lower explosion limit (LEL) sensors and cell voltage levels to detect early stages of a thermal runaway event is insufficient.

Cell-level detection, close to or inside the affected module, has proven the most reliable means of pre-thermal-runaway warning. The early detection of thermal runaway has also proven that a cell can be disconnected, effectively stopping the overheating process.

One important aspect of the protection of LIB systems in ESS is the prevention of thermal runaway and propagation of cell failures. While there are many ways to detect and prevent thermal runaway, off-gas monitoring or off-gas particle detection is, perhaps, the most effective because it provides the most amount of time to react to the condition. Off-gas monitors or detectors are installed at the battery rack level and capable of sensing the off-gas byproducts from a single cell. In this way, they can provide up to 30 minutes of time for investigation and intervention by automatic deactivation of charging before thermal runaway.

Off-gas sensors or detectors must be designed to detect the variety of different gases from the many types of LIB chemistries. The gases emitted during the early stages of battery failure are a precursor to the much larger and more dangerous issue of thermal runaway and potential propagation of fire from cell to cell and module to module. This is why, for thermal runaway prevention, LEL gas detectors are not adequate because the concentrations of flammable gases are not high enough. Flammable gas detection has a role to play in other aspects of the protection of the ESS (see 9.6.5.6).

Off-gas sensors or detectors are typically mounted in each battery rack or module, with the exact location of the sensors or detectors being dictated by the actual rack design. But, in general, the sensors must be mounted in the path of airflow. This could mean that, depending upon rack design, the sensor or detector could be either at the top or bottom of the rack. For specific detection design requirements, refer to the manufacturer's published installation and operation manuals and any relevant regulatory approvals/listings for the intended purpose of "off-gas detection" from the incipient stages of a lithium-ion battery thermal runaway.

To be most effective, the network of sensors or detectors throughout the many battery racks in the ESS must be connected with a central controller that allows for the supervision for failures of the individual sensors and a coordinated response when one or more sensors or detectors detect an off-gas event. The responses can be either automated or human generated.

N G.7.3.6.2 Installation Level Event. Once cells have gone into thermal runaway, the release of gas from a single cell can be 10s of gal (100s of L) of gas with concentration from 20 to 50 percent hydrogen, with other components such as CO, CO₂, and flammable hydrocarbons (HCs) also released. A gas detection system should be installed at the installation level. That would include the ceiling for buildings and in the appropriate air flow streams for containers, enclosures, or cabinets. This detection can be configured to provide early notification at 10 percent lower flammable limit (LFL) and alarm condition at 25 percent LFL. If any of these gas components are detected at rising levels, the implication is a nonburning battery failure. If the batteries have ignited, then these gases will be burned off. As explosion is greater risk than fire, monitoring for installation level gases will take priority over a potential fire condition. The gas detection can be tied to the exhaust system to exhaust gases prior to reaching an explosive level. Evaluation and mitigation measure should be evaluated by a deflagration study and hazard mitigation analysis to determine appropriate response to an installation-level gas event.

N G.7.3.6.3 Effects on H₂ Gas Detection After Suppression Discharge. Hydrogen is a significant percentage of the gases released during thermal runaway of an LIB. Traditional gas detection technology for detection of H₂ is a catalytic bead. A catalytic bead burns the gases across the sensor to determine concentration level or LFL. LIBs also release other HCs during failure. These other HCs will be burned on the sensor and recognized as H₂.

A catalytic sensor will not perform well in a low-oxygen or suppression environment as the sensor's ability to burn the gases will be limited. The sensors might fail or underreport the percentage of LFL. Other technology exists for detection of H₂ but can be overwhelmed and fail in a high H₂ release. In conjunction with a suppression system, a secondary sensor monitoring CO or CO₂ might be necessary to monitor as a reference gas. It is seen that for overheating and overcharging, CO is the most continuously present gas and thus provides a good indication of the full spectrum of gas profiles that can be expected. A similar profile can be found by monitoring CO₂. Rising levels of CO or CO₂ indicate a battery failure or cascading event.

Gas release data should be utilized from the fire and explosion testing at a cell, module, and installation level for evaluation of appropriate gas detection. Cell to module to installation is not always a linear progression; meaning scaling up the test results might not give you an actual gas release. These conditions can change due to additional construction material and incorporated barriers. Installation testing can show more or less propagation than cell- or module-level tests.

N G.7.3.7 Aspirating Smoke Detection (ASD). Fire events in LIB ESS must be detected as early as possible to ensure personnel safety, asset protection, and uninterrupted business operation. Aspirated smoke detection mitigates the risk of fire and the consequences of downtime in an ESS in the following ways:

- (1) Aspirated smoke detectors detect fires at their incipient stage, allowing early intervention for investigation and action before smoke and corrosive gases affect equipment and personnel. Early detection can prevent the spread of fire from one rack to another.
- (2) Early intervention reduces the reliance on active fire suppression or fire department intervention.

- (3) Aspirated smoke detectors monitor all fire stages from incipient to fully developed, providing multiple alarms for staged response. Later stages assure prompt evacuation for life safety of building occupants.
- (4) An aspirated smoke detection system can be designed to reliably detect diluted smoke due to its very sensitive sensing chamber and cumulative sampling (e.g., smoke drawn through multiple sampling holes).
- (5) The system can be designed to accommodate temperature and humidity extremes.
- (6) The aspirated smoke detection system can monitor HVAC outside air intakes and adjust smoke readings to avoid nuisance alarms from outside sources. This feature is particularly important for high sensitivity levels.
- (7) Where a gaseous or sprinkler fire suppression system forms part of the overall fire protection solution, the system can be designed to actuate the release mechanisms flexibly with various systems, from noninterlocked to double-interlocked systems, by different detection schemes, including coincidence detection.
- (8) Aspirated smoke detectors can be mounted in easily accessible areas. This allows for easy and safe system maintenance when sampling in awkward locations such as inside cabinets, above cable trays, under raised floors, in ceiling voids, and in underground cable tunnels/vaults; and will not disrupt operations or cause a security breach of secure areas.

NG.7.3.7.1 Localized Protection (Cabinets). Partially enclosed cabinets containing electrical equipment or batteries are usually ventilated vertically (i.e., bottom to top) or horizontally (i.e., front to back) or could be fully enclosed with active internal cooling. The following are two methods for protecting cabinets with aspirated smoke detectors:

- (1) *Microbore system:* This type of detector is ideally suited for localized cabinet detection where a fire event can be readily identified and traced to an individual cabinet. Sampling locations should be directly in the airflow distribution path where the air exhausts for passively cooled or low-speed active bottom-to-top cooling cabinet configurations, or at a point where air recirculates within fully sealed cabinets with internal cooling. Where a single aspirating unit is used to provide detection across multiple rooms or enclosures, the pressure differential should be within the limits of the system being designed to avoid faults.
- (2) *Large bore (traditional) systems:* For ventilated or fully sealed cabinets with internal cooling, a large bore detector can be dedicated to an individual cabinet or row or bank of cabinets. For ventilated cabinets, sampling locations should be directly within the airflow distribution path at a point where the airflow exhausts. For fully enclosed cabinets, sampling locations should be at the top of the cabinet, or at a point where air recirculates for sealed cabinets with internal cooling.

A capillary tube or down pipe with vented end cap is inserted in the top of the cabinet. A detector can be used to protect a single row of cabinets or multiple rows or banks of cabinets. This arrangement is suitable only for sealed cabinets or cabinets with minimal ventilation.

For vertically ventilated cabinets (i.e., bottom to top) the sampling pipe is placed close to the exhaust vent(s) of the cabinets with sampling holes directly in the path of the main

airflow to optimize the detection. This arrangement allows a fire event to be traced to a particular row or bank of cabinets.

For horizontally ventilated cabinets (i.e., front to back) the sampling pipe is placed close to the exhaust side of the cabinets with sampling holes directly in the path of the exhaust air to optimize the detection. This arrangement allows a fire event to be traced to a particular row or bank of cabinets. For this configuration, the sampling holes coverage area should not exceed 2 ft² (0.2 m²).

NG.7.3.7.2 High-Risk Equipment Protection. Certain equipment in ESS facilities are designated high-risk. The consequences of a fire event within such equipment could create or exacerbate other hazards. Examples of these types of equipment include the following:

- (1) Those that are likely to promote a fast developing fire.
- (2) Those that will generate corrosive and toxic gas species.
- (3) Those whose unnecessary shutdown would result in substantial network service losses.
- (4) System losses that could create conditions for battery failure such as HVAC or BMS system loss.

Sampling location considerations are often similar to those for cabinet protection and include the following:

- (1) Sampling should be conducted within or around high-risk equipment for the earliest possible detection of smoke.
- (2) Where appropriate and within the system design capacity, capillary tubes branched from the main sampling pipe can be used to penetrate equipment or equipment cabinets. Normally, dedicated systems should be used unless in small rooms.
- (3) All sampling pipes should be airtight, firmly secured, and held clear of equipment, especially moving parts, to avoid physical damage to the pipe network or the equipment.

NG.7.3.8 Video Detection. Video detection imaging can be applicable to detection of LIB failure. With proper placement of the detectors, it is possible to detect flame or smoke that is associated with battery failure. It requires a line of sight and might not function in a small container or cabinet.

Video detection can provide the added benefit of visual images. Images can be captured internally or externally to the BESS. First responders can use the images to assess the internal condition of the ESS. Video imaging requires visual light and will not function in a dark container or at nighttime.

The principle of using automatic analysis of real-time video images is for very early smoke or visible gas detection.

NG.7.3.8.1 Video Image Smoke Detection (VISD).

NG.7.3.8.1.1 VISD is a software-based method of smoke detection that has become practical use with the advancement of digital video cameras and increasingly powerful computer processors. VISD systems use sophisticated algorithms, developed through artificial intelligence, to analyze images for smoke through changes in features such as brightness, contrast, edge content, loss of detail, and motion.

The detection equipment can consist of cameras producing video signals and a processing unit(s) that maintain the software—either embedded on the camera or separate computer—and interface with the fire alarm control unit through relay dry contacts.

VISD can be useful for detecting smoke and/or flame. VISD can monitor, in most cases, floor to ceiling so it is effective in high-ceiling applications.

N G.7.3.8.1.2 Installation cameras are typically mounted with a view above racks, and as much of the sides and top of the battery as possible, so that the smoke or products of off-gassing can be seen and tracked from their lowest point, or inception. Some VISD systems use alarm zones, or virtual areas within the camera field of view, targeting specific areas for alarm while avoiding false alarms from movement in the space.

VISD is used solely for indoor applications as natural lighting changes and darkness can prohibit effective detection.

VISD measures light movement across pixels to detect and track smoke or visible gasses. Care should be given to comply with the manufacturer's recommendations for minimum light levels.

Care should be given when applying the technology in rooms with high airflow or air changes that would break up or remove the smoke before it can be detected.

Where applying VISD in test cells, a means to disable alarm outputs (such as a maintenance lock-out) during work by personnel in the cell is recommended to avoid false alarms so that highest sensitivity settings can be used.

Where listed/approved VISD systems are required, they should be designed, installed, and maintained in accordance with the requirements of *NFPA 72*.

N G.7.4 Battery Management System Safety Functions. The battery management system should be equipped with the following safety functions at a minimum:

- (1) *High cell temperature trip (cell level):* This function isolates the module or battery rack when detecting cell temperatures that exceed limits. A common design is to have modules hard-wired in series within a rack. Therefore, the smallest unit that can be isolated is generally the rack. Where a design accommodates it, isolating a module is acceptable.
- (2) *Thermal runaway trip (cell level):* This function trips the entire system when a cell is detected to have entered a thermal runaway condition. In scenarios involving a thermal runaway, this function is the first to activate when thermal runaway conditions are detected.
- (3) *Rack switch fail-to-trip (rack level):* This function identifies any failure from the pack switch to trip once a trip command is initiated. The rack switch is also known as the "pack switch." It is a switch that disconnects a single rack in response to an abnormal condition. The rack switch is shown separately from the "master" level in Figure G.7.4 for clarity. It is generally incorporated into the BMS.
- (4) *Inverter/charger fail-to-trip (supervisor level):* This function initiates a trip command to an upstream breaker to isolate the ESS if the inverter/charger fails to respond to a trip command. The "supervisor" control system controls the entire system, including the combination of racks, the environmental support systems, and the charging/discharging status. The supervisor level should isolate the ESS if the inverter/charger fails to trip on an appropriate signal, or if communication is disrupted between the inverter/charger and the supervisor control.

See Figure G.7.4 for an explanation of management levels.

N G.7.5 Online Condition Monitoring.

N G.7.5.1 An online condition monitoring system should be provided that will monitor battery room temperature and the following parameters, at a minimum, at the battery module or cell level:

- (1) Charging and discharging voltage and current
- (2) Temperature
- (3) Internal ohmic (resistance)
- (4) Capacity
- (5) State of charge (SOC)
- (6) State of health (SOH)
- (7) Alarm or fault log

N G.7.5.2 The online condition monitoring system should include the following features:

- (1) The ability to transmit data to a constantly attended location or specific operations personnel
- (2) The ability to generate alarms when unusual conditions are detected
- (3) The ability to analyze monitored parameters and generate a summary of the condition of the battery
- (4) Security to prevent unauthorized changes of critical parameter limits, such as voltage, temperature, and current, which are essential to maintain reliable LIB operation
- (5) Self-diagnostic capability

N G.7.6 Electrical Disconnects.

N G.7.6.1 A disconnect device for maintenance needs or abnormal events should be provided for each rack.

N G.7.6.2 A method of manual, remote, and local disconnect for the ESS should be provided. A remote disconnect should be in an accessible area that is monitored 24/7. A local disconnect should be provided adjacent to the ESS space.

N G.7.6.3 Temperature monitoring with high alarm for ESS room, building, or enclosure should be provided. Alarms should be routed to a continuously attended location or specific operations personnel.

N G.7.7 ESS Rack.

N G.7.7.1 Ground-Fault Protection. Dc ground-fault protection for grounded battery systems should be provided. For ungrounded battery systems, dc ground-fault monitoring with an alarming function should be provided. The alarm should be routed to a constantly attended location or specific operations personnel.

N G.7.7.2 Overcurrent Protection. Overcurrent protection against overload and short-circuit faults should be provided.

N G.7.7.3 Voltage Protection. Over- and undervoltage protection against overcharging and over-discharging should be provided.

N G.8 Flammable Gas, Deflagration Hazard Studies, and Use of NFPA 68 and NFPA 69 for Lithium-Ion Batteries. (Reserved)

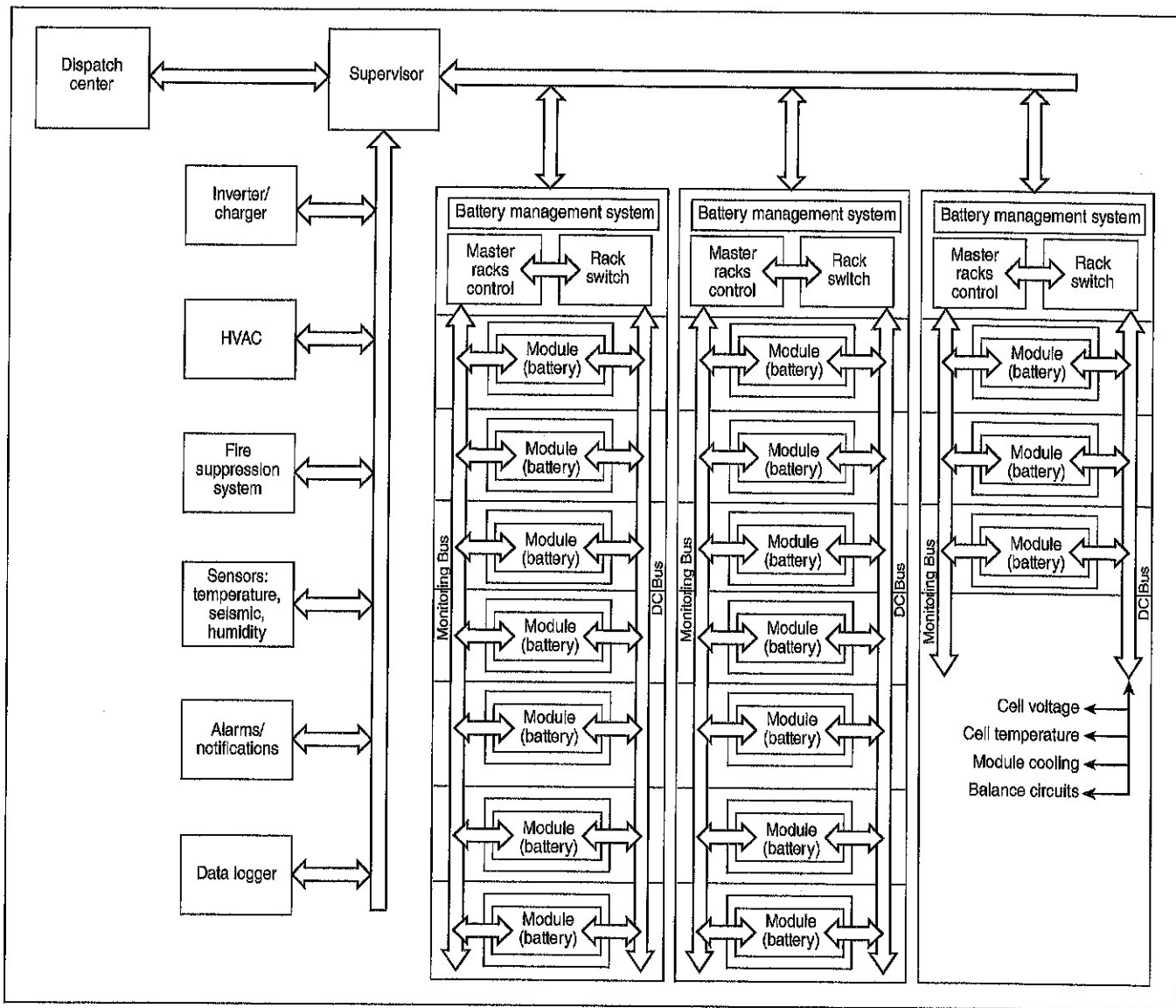

FIGURE G.7.4 Management Levels.

N G.9 LIB Construction and Installation Guidance.

N G.9.1 General Location and Construction. The ESS room, building, walk-in unit, enclosure, container or cabinet, or otherwise nonoccupiable enclosure should be located as following, listed in order of preference:

- (1) In an enclosure outside and away from critical buildings or equipment in accordance with Section G.9.2 (see Figure G.9.1, location 1)
- (2) In a dedicated building containing only ESS and associated support equipment in accordance with Section G.9.3 (see Figure G.9.1, location 2)
- (3) In a dedicated exterior cutoff room that is accessible for manual firefighting operations and is constructed in accordance with Section G.9.4 (see Figure G.9.1, location 3)

- (4) In a dedicated interior corner cutoff room that is accessible for manual firefighting and is constructed in accordance with Section G.9.4 (see Figure G.9.1, location 4)
- (5) In a dedicated interior cutoff room that is accessible for manual firefighting and is constructed in accordance with Section G.9.4 (see Figure G.9.1, location 5)

N G.9.2 ESS Enclosures.

N G.9.2.1 Minimum space separation should be provided between ESS enclosures and adjacent buildings or critical site utilities or equipment at a distance that minimizes the exposure to the building from fire or explosion hazards.

N G.9.2.2 Minimum space separation of 20 ft (6 m) should be provided between adjacent ESS enclosures with noncombustible walls.

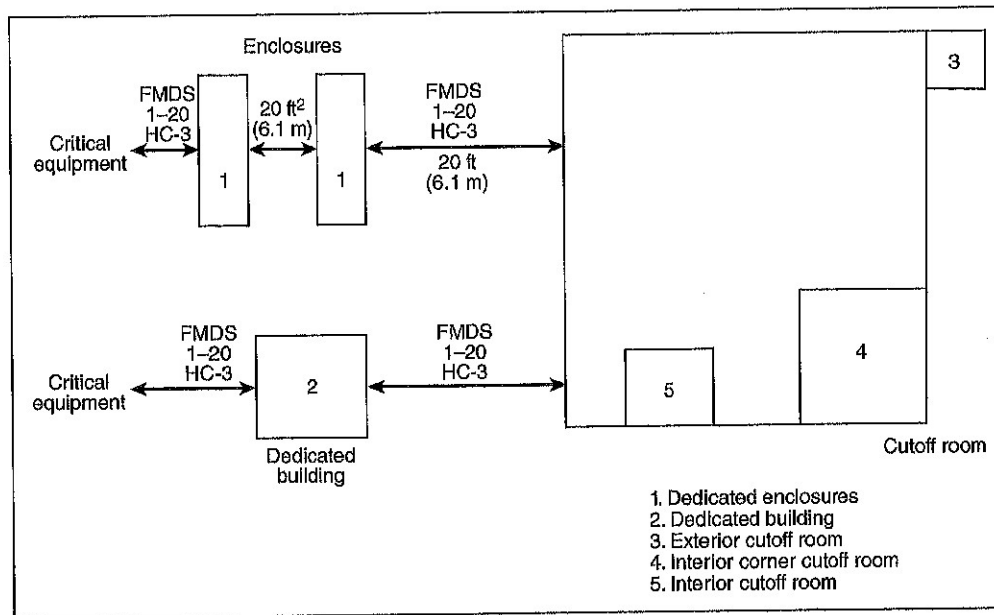

FIGURE G.9.1 ESS Location by Preference

N G.9.2.2.1 If the walls are combustible, separation distance should be extended to minimize exposure from one enclosure to another.

N G.9.2.2.2 If the space separation between ESS enclosures is less than 20 ft (6 m), a thermal barrier, rated at a minimum of 1 hour, should be provided on the inside or outside of the enclosure.

N G.9.2.3 Where enclosure vents or other penetrations are provided, they should be directed away from surrounding equipment and buildings. In a fire, these enclosures might have vents or penetrations that could allow hot gas and products of combustion to escape the enclosure, causing an exposure to adjacent equipment or buildings. Penetrations could include electrical cabling, doors, HVAC units, and so on.

N G.9.3 Dedicated ESS Building or Enclosure Larger Than 500 ft² (46.5 m²). A prefabricated container or enclosure that is larger than 500 ft² (46.5 m²) should be treated as a building.

N G.9.3.1 A dedicated ESS building should be constructed of noncombustible materials.

N G.9.3.2 A minimum space separation between dedicated ESS buildings and other facility buildings or critical site utilities or equipment should be provided to minimize the potential for fire spread to an adjacent building or piece of equipment.

N G.9.3.3 Damage-Limiting Construction (DLC).

N G.9.3.3.1 DLC should be provided to prevent building collapse in the event of an explosion involving the off-gas products from ESS failure.

N G.9.3.3.2 DLC should be provided to prevent collapse of any shared walls with the main building.

N G.9.3.4 Mechanical Ventilation.

N G.9.3.4.1 The ventilation system should be designed to take suction at or near the ceiling because most constituent gases

released as a result of thermal runaway are lighter than air. Therefore, upward flow of ventilation air provides the best opportunity for timely detection of flammable gases.

N G.9.3.4.2 A combustible gas detector that will alarm at the presence of flammable gas, shut down the ESS, and cause the switchover to full exhaust of the ventilation system should be installed in the suction duct or at the ceiling. Since the only reason for the presence of flammable gas is thermal runaway, a simple yes/no detector is sufficient.

N G.9.3.4.3 Combustible gas detection in the ventilation system is not needed where combustible gas detection arranged for rack shutdown is provided in each ESS rack as part of the battery management system.

N G.9.3.4.4 Exhaust air should be removed through a system of blowers, fans, and ductwork terminating outdoors away from air inlets, doorways, and other openings.

N G.9.3.4.5 Ductwork should be constructed of noncombustible materials.

N G.9.3.4.6 Make-up air inlets should be provided in exterior walls, in a remote location from exhaust outlets to prevent entrainment of exhaust gases.

N G.9.3.4.7 Ventilation systems should be arranged to recirculate air into the room with an approved or listed combustible gas detector arranged to stop recirculation and return to full exhaust when flammable gas is detected in the ductwork.

N G.9.3.4.8 The ventilation system controls should be arranged to alarm to a constantly attended location or specific operations personnel. Modern communications technology allows for specific personnel to be notified via text message or other automated messaging. Where such a system is used, it should be tested monthly to ensure communication is available. Users should also consider alerting multiple personnel to account for vacations, out-of-range travels, and so on.

NG.9.3.4.9 HVAC systems should be designed to maintain temperatures within operating limits in the event of a single component failure.

NG.9.3.4.10 The HVAC system should be arranged to alarm to a constantly attended location or specific operations personnel if any part of the system fails.

NG.9.4 ESS Cutoff Rooms. A minimum 2-hour fire-rated room, floors, walls, and ceiling should be provided in accordance with 4.3.6 of NFPA 855. The following should also be provided:

- (1) Listed or approved fire doors with the same room rating
- (2) Listed or approved fire barriers for all floor, ceiling, and wall penetrations

NG.10 Guidance on Inspection and Maintenance for Installed LIB Fire Protection Systems.

NG.10.1 General.

NG.10.1.1 This section covers the inspection and maintenance procedures necessary for proper function and operation of fire safety and suppression systems for lithium-ion BESS facilities.

NG.10.1.2 Upon installation, all fire protection systems should be inspected before operation and tested in accordance with applicable NFPA standards. Where appropriate standards do not exist, inspection and test procedures outlined in the purchase and design specifications should be followed.

NG.10.1.3 Plant lockout/tagout procedures should be strictly followed.

NG.10.1.4 Regular inspection and maintenance of systems should be maintained to ensure proper functioning of the system. The suitable time intervals depend mainly on the consistency of the systems in the facility.

NG.10.1.5 Inspections should be conducted prior to facility energization and time intervals for all inspection and maintenance should be determined in that process. Future maintenance intervals, which are necessary to provide safe operation, should be determined and documented accordingly within facility/process operating instructions. Inspection and maintenance procedures should include a list of required personal protective equipment (PPE).

NG.10.1.6 All personnel conducting inspections, maintenance, and testing should be trained on the specific hazards and equipment of the facility.

NG.10.2 Testing, Inspection, and Maintenance.

NG.10.2.1 All fire protection systems and equipment should be periodically inspected, tested, and maintained in accordance with applicable national fire codes. (See Table G.10.2.1 for guidance.)

NG.10.2.2 Testing, inspection, and maintenance should be documented with written procedures, results, and follow-up corrective actions recorded and tracked for closure.

NG.10.2.3 A reduction of the state of charge (SOC) to 30 percent should be confirmed prior to performing testing or maintenance procedures.

NG.10.2.4 If maintenance is performed on a damaged battery, the damaged battery should be closely monitored until person-

Table G.10.2.1 Reference Guide for Fire Equipment Inspection, Testing, and Maintenance

Item	NFPA Document No.
Supervisory and fire alarm circuits	72
Fire detectors	72
Manual fire alarms	72
Sprinkler water flow alarms	25/72
Sprinkler and water spray systems	25/72
Halogenated agent, chemical, and CO ₂ systems	12/12A/17/2001
Fire pumps and booster pumps	25/72
Water tanks and alarms	25/72
PIV.s and OS&Y valves	25/72
Fire hydrants and associated valves	13/24
Fire hose and standpipes and hose nozzles	1962/25
Portable fire extinguishers	10
Fire doors and dampers	80/90A
Smoke vents	204
Emergency lighting	110
Radio communication equipment	1221
Audible and visual signals	72
Water mist fire protection systems	750

nel can remove the battery or confirm that no stranded energy remains.

NG.10.3 Lockout/Tagout.

NG.10.3.1 Lockout/tagout (LOTO) procedures in 29 CFR 1910.147 and 29 CFR 1910.269(d), or the local country equivalents, should be followed prior to entering or performing maintenance on BESS and associated protection systems.

NG.10.3.2 Review the facility LOTO plan and ensure that all employees are trained to the degree necessary to execute their responsibilities as related to the procedure.

NG.10.3.3 Prior to beginning any LOTO procedures, personnel should be made aware that equipment lockout/tagout is going to be taking place. Affected employees should be informed that power will be turned off, the reason it will be off, and not to operate equipment. Responsible or qualified employees should be informed of all energy sources and locations, including stored energy.

NG.10.3.4 Following the application of the lockout or tagout devices to the energy isolating devices, qualified personnel should verify that stored or stranded energy in the equipment is safely disconnected and managed (see NFPA 70E).

NG.10.3.5 Verification that equipment is isolated from the energy source can be achieved by means of attempting to operate or testing for the absence of voltage.

NG.10.3.6 Facility procedures for grounding should be followed as applicable to the work being performed. Any conductive battery racks, cases, or trays must be connected to an equipment grounding conductor.

NG.10.3.7 LOTO procedures should remain in place until work is complete. If the work requires more than one work period, energy source, location, or involves another individual crew, then a complex LOTO procedure should be followed.

Ventilation

	There is adequate ventilation for batteries. (NEC 480.10, 706.20(A))
	Batteries/enclosures contain ventilation equipment to prevent excessive accumulation of gas pressure or gas ignition. (NEC 706.20, 480.10)
	Rooms or spaces containing ESS are separated from other areas of the building by fire barriers with a minimum fire resistance rating of two hours and horizontal assemblies with a minimum fire resistance rating of two hours constructed in accordance with the <i>NYS Uniform Building Code</i> , and local laws and ordinances. (IFC 2018 1206.2.8.2) (NFPA 855 Section 4.3.6)

Connections and Terminations

	Measures have been taken to prevent corrosion of cell terminations.
	Electrical connections do not put mechanical strain on battery terminals. (NEC 480.4, 110.14(A))
	Overcurrent protection of ungrounded conductors have overcurrent protection device(s) located as close as practicable to the battery terminals in an unclassified location. (NEC 480.5, 706.15)
	Battery circuit and equipment are protected by overcurrent protective devices as close as practicable to the storage battery terminals in accordance with Article 240 of <i>NFPA 70</i> . (NEC 240.21(H), 705.30, 706.65(A))
	Unless the short-circuit currents from all sources do not exceed the ampacity of the conductors, storage battery inverters are protected by overcurrent protective devices from all other sources. (NEC 705.30)
	A listed current-limiting overcurrent protective device is installed adjacent to the ESS for each dc output circuit. (NEC 706.31(C))
	In an ac-coupled system, the plug-in-type circuit breaker connected to the output of the storage battery or multimode inverter is secured in accordance with 408.36(D) of <i>NFPA 70</i> . (NEC 408.36(D), 710.15(E))
	Storage battery, multimode, and utility-interactive inverter output circuit breakers that are marked "Line" and "Load" are not back-fed. (NEC 408.36(D), 110.3(B), 705.30(D))
	Single 120-volt inverter in ac-coupled systems do not supply back-up loads containing multiwire branch circuit or any 240-volt outlets. Such action can overload the common neutral in such a wiring method (NEC 710.15(C))

Monitoring and Charge Control

	Charge controllers are compatible with the battery or ESS manufacturer's electrical ratings and charging specifications. (IFC 2018, 1206.2.10.3)
	Charge controller is properly installed to prevent overcharging or damaging batteries. (NEC 690.72, 706.33)
	PV systems with diversion charge controllers used for regulating the charging of a battery have a second independent means to prevent battery overcharge. (NEC 690.72(B)(1))
	For systems with charge controllers that are not inverter-integrated, indicate if the charge controllers with direct photovoltaic source or output circuit inputs from the grounded photovoltaic array or arrays are provided with dc ground-fault protection. (NEC 690.41)
	Indicate if the charge controller ground-fault detection is capable of detecting a ground fault, provides an indication of the fault, interrupts the flow of fault current, and either isolates the faulted array section or disables the charge controller to cease the export of power. (NEC 690.41(B))
	Diversionary charge controllers with utility-interactive and multimode inverters have a second independent controller to prevent battery overcharge in the event the diversion loads are unavailable or the diversion charge controller fails. (NEC 706.33(B)(3)(b))

▲ FIGURE G.10.7.3 Continued

Disconnecting Means

	A dc disconnect is installed on the dc battery system. (NEC 480.7, 706.7)
	A dc disconnecting means is provided for all ungrounded conductors derived from a dc stationary battery system with a voltage over 60 volts dc. (NEC 706.15)
	A disconnecting means is provided for all ungrounded conductors derived from an ESS and is readily accessible and located within sight of the ESS. (NEC 706.30(C))
	Battery circuits subject to field servicing where currents can exceed 240 volts nominal between conductors or to ground have provisions to disconnect the series-connected strings into segments not exceeding 240 volts nominal for maintenance by qualified persons. Non-load-break bolted or plug-in disconnects are permitted. (NEC 706.15(E)(1))
	ESS exceeding 100 volts between conductors or to ground have a disconnecting means, accessible only to qualified persons, that disconnects ungrounded and grounded circuit conductor(s) in the electrical storage system for maintenance. This disconnecting means does not disconnect the grounded circuit conductor(s) for the remainder of any other electrical system. Anon-load-break-rated switch is permitted to be used as a disconnecting means. (NEC 706.30(C))
	Where battery energy storage system input and output terminals are more than 5 ft (1.5 m) from the connected equipment or where these terminals pass through a wall or partition comply with all of 706.7(E) of <i>NFPA 70</i> . (NEC 706.7(E))
	If the disconnecting means required by 706.7(E)(1) of <i>NFPA 70</i> is not in line of sight of the connected equipment, a second disconnecting means at the connected equipment has been provided. (NEC 706.7(E)(2))
	Where a disconnecting means located in accordance with 480.7(A) of <i>NFPA 70</i> is provided with remote controls to activate the disconnecting means and the controls for the disconnecting means are not located within sight of the stationary battery system, the disconnecting means is lockable in the open position. (NEC 480.7(D))
	Verify that the utility ac disconnect is located within sight of and within 10 ft (3 m) of the main electrical service.
	The equipment grounding lug is as specified by the manufacturer. Verify that the lug matches the part number as specified on the inside of the door. Verify that the grounding lugs are located where specified by the manufacturer. (NEC 110.3(B))
	Remove any insulating finish, such as paint, under the equipment grounding lug prior to installation. (NEC 250.8, 250.12)
	Integrated disconnects follow the maximum height requirements for disconnects.

Interconnection

	The interconnection methods comply with 705.11, 705.12 of <i>NFPA 70</i> if connected to other energy sources.
--	--

Signage

	Signage complies with ANSI Z535 and includes the following information: <ul style="list-style-type: none"> (1) Labeled "Energy Storage Systems" with symbol of lightning bolt in a triangle (2) Type of technology associated with the ESS (3) Special hazards associated with the ESS (4) Type of suppression system installed near the ESS (5) Emergency contact information
	A permanent plaque or directory complying with 110.21B of <i>NFPA 70</i> that denotes the location of all electric power source disconnecting means on or in the premises is installed at each service equipment location and at the locations(s) of the system disconnect(s) for all electric power production sources capable of being interconnected. (NEC 706.11)
	Equipment containing overcurrent devices in circuits supplying power to a busbar or conductors supplied from multiple sources is marked to indicate the presence of all sources. (NEC 705.12(B)(3))
	PV system output circuit conductors are marked to indicate the polarity where connected to battery energy storage systems. (NEC 690.31)

▲ FIGURE G.10.7.3 Continued

Signage (continued)

	Dc system conductors of 6 AWG or smaller are identified for negative or positive polarity per 210.5(C)(2)(a) of <i>NFPA 70</i> .
	Where controls to activate the disconnecting means of a battery are not located within sight of a stationary battery system the location of the controls is field marked on the disconnecting means. (NEC 480.7(D))
	Where the battery energy storage device disconnecting means is not within sight of the PV system ac and dc disconnecting means, placards or directories are installed at the locations of all disconnecting means indicating the location of all disconnecting means. (NEC 705.10, 706.7(E)(5))
	Where the sum of inverter overcurrent device rating(s) and the rating of the overcurrent device protecting the busbar exceeds the ampacity of the busbar, and the sum of ratings for all overcurrent device ratings in the panelboard (both load and supply, but excluding the device protecting the busbar) does not exceed the busbar ampacity, the following label is applied to the distribution equipment (NEC 705.12(B)(2)(c)): WARNING: THIS EQUIPMENT FED BY MULTIPLE SOURCES TOTAL RATING OF ALL OVERCURRENT DEVICES, EXCLUDING MAIN SUPPLY
	Where a busbar is the point of connection for the inverter(s) and is rated to 120 percent in accordance with 705.12(2)(3)(b) of <i>NFPA 70</i> , a warning label with the following language is applied to the distribution equipment adjacent to the back-fed breaker from the inverter (NEC 705.12(B)(2)(b)): WARNING: INVERTER OUTPUT CONNECTION: DO NOT RELOCATE THIS OVERCURRENT DEVICE
	All battery and battery management equipment and associated switchgear are marked and labeled according to all applicable codes, including arc flash incident calculations for the safety of operation and maintenance personnel required by <i>NFPA 70</i> and OSHA.
	If a battery dc disconnecting means is not provided at the batteries, the disconnecting means are legibly marked in the field. The marking are of sufficient durability to withstand the environment involved and include the following (NEC 480.7(F)): (1) Nominal battery voltage (2) Maximum available short-circuit current derived from the stationary battery system (3) Date the calculation was performed for the value of list item (2)

▲ FIGURE G.10.7.3 *Continued*

NG.11.2.2 The following minimum LIB ESS system information should be included:

- (1) Identification of technologies present, the potential hazards associated with the systems, and methods for responding to fires and incidents associated with the ESS.
- (2) Procedures for safe shutdown, de-energizing, or isolation of equipment and systems under emergency conditions to reduce the risk of fire, electric shock, and personal injuries, and for safe start-up following cessation of emergency conditions. The location of all electrical disconnects in the building and understanding that electrical energy stored in ESS equipment cannot always be removed or isolated. Procedures for shutting down and de-energizing or isolating equipment to reduce the risk of fire, electric shock, and personal injury hazards.
- (3) Maintenance records and system manual information
- (4) Procedures for inspection and testing of associated alarms, interlocks, and controls.
- (5) Procedures to be followed in response to notifications from the battery energy storage management system, where provided, that could signify potentially dangerous conditions, including shutting down equipment, summoning service and repair personnel, and providing agreed-upon notification to fire department personnel for potentially hazardous conditions in the event of a system failure.
- (6) Emergency procedures to be followed in case of fire, explosion, release of liquids or vapors, damage to critical moving parts, or other potentially dangerous conditions. Procedures can include sounding the alarm, notifying the fire department, evacuating personnel, de-energizing equipment, and controlling and extinguishing the fire. Recognition that stranded electrical energy in fire-damaged storage batteries and other ESS has the potential for reignition after initial extinguishment.
- (7) Response considerations similar to a safety data sheet (SDS) that address response safety concerns and extinguishment where an SDS is not required.
- (8) Procedures for dealing with battery energy storage system equipment damaged in a fire or other emergency event, including maintaining contact information for personnel qualified to safely remove damaged battery energy storage system equipment from the facility.
- (9) Procedures and schedules for conducting drills of these procedures.

NG.11.3 Guidelines. Battery ESS based on electrochemical technologies represent the majority of ESS being designed and installed. The safe operation of electrochemical ESS is critical—especially when installed inside occupied structures. The primary concerns of the fire service with this type of installation would include the implications of overheating via internal or external heat source, thermal runaway, potential deflagration event in enclosed spaces, and the effective operation of fire detection, suppression, and smoke exhaust systems. There are additional concerns to be considered where assessing firefighter responses to electrochemical ESS.

Handover procedures for potentially damaged systems should be developed for fire departments to ensure the timely response of qualified technical representatives to manage safety issues. These procedures would also cover issues such as the removal or recycling of damaged equipment. Another procedural component is the realization that damaged ESS system components could include significant stored or stranded

energy with no known method for safe dissipation. Stored or stranded energy could be defined as energy that remains in a battery after the system has been shut down.

NG.11.4 Suppression Systems. Some ESS design validations have included pre-engineered inert or clean-agent fire suppression systems for fire protection. These system installations were often approved without validation based on fire and explosion testing in accordance with 9.1.5 by nationally recognized testing laboratories. Evidence-based data is needed to ensure ESS designers specify appropriate fire protection systems based on the material involved and physical design characteristics. Several early research papers from multiple organizations, including NFPA's Fire Protection Research Foundation, and third-party engineering groups have shown that fires involving lithium-ion cells must be cooled to terminate the thermal runaway process. Water is the agent of choice, yet system cabinet design could pose a significant barrier to the efficient application of water while simultaneously allowing the free movement of fire and combustion gases.

One of the more challenging types of incidents will be one where no signs of overheating are visible, and no information is available via integral displays. This places the responding firefighter in the challenging position of determining what is safe or not with very little information. Integrated energy management systems (EMS) are designed to monitor and manage critical safety parameters of the battery such as cell temperature, voltage, and available current. While this data might prove valuable to responders to best understand the current state of the battery, there is no standard for manufacturers to provide a user interface to access the state of these parameters or a method to interface with monitored alarm systems within the building. Responders should attempt to gather any visible information prior to shutting down the system unless there is clear evidence of imminent danger. Additionally, the response of a qualified and trained individual in ESS should be made available to assist the firefighters in the event of damage to an installed system.

NG.11.5 Overheated Batteries. The process of charging/discharging results in heat dissipation from cells. An optimum overall system design should include cascading layers of hardware and software protection, including at the battery cell, module or pod, and rack levels. Should a fault occur and overheating of a cell continues, damage could occur resulting in swelling, off-gassing, fire, or explosion. Proper response to an overheated battery is needed.

Fires in electrochemical ESS are often a result of a failure mode called *thermal runaway*. Thermal runaway can simply be defined as the process in which a battery creates heat within an individual cell but cannot dissipate that heat, resulting in dynamic temperature increase. Initial signs of thermal runaway might include pressure increase at the cell level, temperature increase, and off-gassing. As the process continues, additional signs might include vent gas ignition, exploding cells, projectile release, heat propagation, and flame propagation.

As the failure cascades, responders should also be prepared for toxic and potentially explosive gas release. Though fire and explosion testing in accordance with 9.5.3.2 to determine battery burn outcomes remains incomplete, including toxic gas release calculations, responders should treat them as highly dangerous ECE hazardous materials and use their full suite of PPE and breathing apparatus when responding.

Proper response to electrochemical ESS fires should include the following procedures and steps:

- (1) System isolation and shutdown
- (2) Hazard confinement and exposure protection
- (3) Fire suppression
- (4) Controlled ventilation

N G.11.6 Suppressing Agent Choice Considerations. Water is considered the preferred agent for suppressing lithium-ion battery fires. Water has superior cooling capacity, is plentiful (in many areas), and is easy to transport to the seat of the fire. While water might be the agent of choice, the module/cabinet configuration could make penetration of water difficult for cooling the area of origin but might still be effective for containment. Water spray has been deemed safe as an agent for use on high-voltage systems. The possibility of current leakage back to the nozzle, and ultimately the firefighter, is insignificant based on testing data published in the Fire Protection Research Foundation report: *Best Practices for Emergency Response to Incidents Involving Electric Vehicles Battery Hazards: A Report on Full-Scale Testing Results*. Firefighting foams are not considered effective for these chemistries because they lack the ability to cool sufficiently and can conduct electricity. There is also some evidence that foams might actually encourage thermal runaway progression by insulating the burning materials and exacerbating heat rise.

Firefighting dry-chemical powders can eliminate visible flame. However, they lack the ability to cool burning battery components. Quite often, even if visible flame is removed, the thermal runaway inside the battery will continue resulting in reignition. Carbon dioxide and inert gas suppressing agents will also eliminate visible flame but will likely not provide sufficient cooling to interrupt the thermal runaway process. ESS with clean-agent suppression systems installed have ventilation systems that are tied in with the fire detection and control panel so that the HVAC shuts down and dampers close to ensure the agents have sufficient hold times at the proper concentration levels to be effective suppressants. In some fire suppression systems, the HVAC recirculates and does not shut down, which provides a means of dispersing the clean agents. Responders must ensure adequate hold time has occurred prior to accessing battery room/container. Manufacturer-recommended times should be made clear. These agents might also reduce flammability by suppressing oxygen levels, but data has identified that flammable gases will continue to be produced due to the continued heating and could create an environment ripe for flashover or backdraft when oxygen is reintroduced into the system.

However, there is anecdotal evidence that many suppressants could work to suppress burning batteries. Battery chemistry plays a significant role in suppressant choice, as some suppressants will perform well on a single chemistry while others might work well on a suite of battery chemistries. Additionally, some suppressants might be inappropriate for certain battery chemistries, and their release could create a more dangerous situation.

In addition, most suppressants only provide a limited application time/number of uses. The practicality of a single-use suppressant should be discouraged for installations where a cascade event involving time-delayed subsequent ignition could occur.

When choosing a suppression system, the following should be considered:

- (1) Cooling effect
- (2) Availability
- (3) Portability
- (4) Conductivity
- (5) Available testing data
- (6) Cascading protections

N G.11.7 Fire Detection and Suppression.

N G.11.7.1 Fire Detection. Battery management systems are primarily designed to monitor temperatures and voltages of cells and modules. They can be designed to shut down the affected charging/discharging circuits in the event of out-of-parameter conditions but might not be able to determine whether a fire is actually occurring. Fire detection should be designed into the ESS installation.

N G.11.7.2 Passive Fire Control. Passive fire control features should be designed to meet the unique challenges of managing electrochemical ESS fires. Passive fire control features should be designed to limit the cascading effects of fire spread. This might include cell to cell (built into the module), module to module (built into the rack/or pack), rack to rack (built into the ESS room or container), or even protection from system-to-system propagation.

N G.11.7.3 Suppression Tactics. As previously mentioned, battery components are often housed in cabinets or other configurations that can serve to protect the components and thus limit the ability of fire stream penetration. Firefighters should never use piercing nozzles and long penetrating irons. It is recommended that firefighters use the reach of the water stream instead but should never be up close to these installations. Mechanically damaged cells or puncturing unburned or undamaged cells can result in the immediate ignition of those cells. In addition, internal shorting within the cabinets could create an electrocution risk. The use of salt water on a damaged system will cause more electrical leakage back to the water appliance. Only unadulterated fresh water should be used on ECE hazardous materials.

Movement of damaged cells might result in arcing or reignition if active material or cells remain in the modules. Modules should not be moved without consultation from qualified personnel. Firefighter should never attempt to "overhaul" a damaged ECE hazardous material.

Ventilation during suppression is critical. Research has shown that Li-ion batteries might continue to generate flammable gases during and after extinguishing. In addition, testing has shown that during sprinkler suppression, removal of combustion and flammable gases emitted from the battery significantly improves the effectiveness of the suppression. Ventilation of an enclosure does not remove the potential of explosion. Ventilation manual activation devices that can be used in enclosure to exhaust flammable and toxic gases from within the enclosure must be remote from the installation and marked for fire department use. This option of ventilation of an enclosure should be in consultation with the system SME. No ventilation should be attempted by the fire service until more information is gathered and the area around the installation is secured.

Testing has shown that electrical current leakage back through hose streams using unadulterated fresh water will not be a shock hazard when appropriate streams are used and distances maintained. Firefighters that use tower ladders (i.e., buckets) should be aware of explosion hazards and should not be in the explosion area when operating a water source from these types of apparatus. In cases where systems are destroyed and electric potential is shown to be minimal, close-range engagement with hoses for drowning modules can be performed to provide more direct cooling. During postfire operations, SCBA should continue to be worn by all persons near the damaged ESS, especially where systems are in confined or poorly ventilated spaces or have not been sufficiently cooled yet. There is a concern that the buildup of these gases can cause an explosion even after the fire has been put under control. Gases, and CO in particular, should be monitored during this period, as dangerous buildups have been observed during postfire testing. If possible, batteries should be monitored for residual heat and temperature, as reignition is a possibility in cells that are not sufficiently cooled.

Care should be taken to secure the area where the batteries are located and ensure that the heat has been removed and that the batteries are not at risk of being electrically shorted or mechanically damaged. This should be done at the guidance of a qualified technician. At this point, the fire scene should be handed over to the owner, operator, or responsible party appointed by the site owner. Though trace amounts of heavy metals such as nickel and cobalt can be deposited from combustion of the batteries, these elements are not expected to be present in large quantities or in quantities larger than any other similar fire. In most instances, water exposed to the batteries shows very mild acidity, with an approximate pH of 6. Runoff-water pH can be monitored during firefighting operations but should not pose a greater risk than normal firefighting runoff. In unique cases where a system on fire poses little or no risk to the surrounding uninvolved equipment or the environment, it is reasonable to assume a defensive posture and allow the system to burn itself out. Some typical steps for this approach include local municipal firefighters responding to the scene to make sure that the flames do not spread beyond the property perimeter, having ESS operations personnel arriving at the scene to review the situation and conditions, and then allowing the fire to burn out. This option should only be considered when no risks are posed to the environment and the risk to firefighting operations is great or unknown. It is up to the site owner/operator to communicate with fire services in the event of an emergency to relay vital system information to fire services.

N G.11.7.4 Flooding and Seismic Influences. Flooding can induce electrical damage to ESS that should be taken into consideration after water has receded. Battery systems in earthquake-prone zones should be seismically tested and certified for such abuse. Systems damaged in earthquakes might be prone to fire if cells have been mechanically damaged or power electronics are damaged and operating improperly, leading to electrical overcharge or other abuse conditions that can cause fire. In addition, if there is an extended power outage for several days, balance of system power might be out, and ventilation fans or automatic suppression systems might be inoperable, leading to more hazardous fire conditions.

N G.11.7.5 Emergency Response to ESS Incidents. Responses to ESS incidents should take into consideration the range of possible conditions and associated hazards as specified in

Annex B. The response should include commonly accepted practices with any hazmat response, including isolating the area to all personnel, confirming location and type of alarm, performing air monitoring, managing ventilation/exhaust, and suppressing fires. Since this type of ECE hazardous material is in a category by itself, firefighters need to employ protective measure that are specific to the chemistry that they are responding to.

N G.11.8 Site Access and Conditions First Responder Hazards.

N G.11.8.1 Upon Arrival. The following actions should be taken by first responders upon arrival at an ESS incident:

- (1) Stage fire trucks upwind.
- (2) Use binoculars to determine scene size-up.
- (3) Attempt to isolate the enclosure that is damaged/on fire by confirming that the enclosure is no longer charging or discharging electrical energy.
- (4) Work with the SME representative to determine when it is safe to enter the area. Do not enter the area until authorized to do so by the SME. Never assume that the fire is out based on a visual observation. The batteries themselves are the largest risk within the facilities. While fires can start in the inverters as well, the greatest risk for the site would be a battery fire that could lead to thermal runaway.
- (5) Contact person or company responsible for operation and maintenance of the system.
- (6) Continue temperature monitoring to ensure mitigation of overheating condition; never enter a facility until the SME representative is on-site.
- (7) Isolate area of all nonessential personnel and keep the public away.
- (8) Review status of both building and ESS alarm system with available data.
- (9) Review status of any fire protection system activation.
- (10) Perform air monitoring of all connected spaces.
- (11) Never assume a fire is out—reignition is common.
- (12) Use respiratory protection due to chemicals being produced during the fire—SCBA should be used at all times while in and around the hazard during firefighting efforts as well as during any overhaul and recovery required by fire department personnel.
- (13) Determine if tankers or drop tanks are needed to supply enough water to fight the fire.
- (14) Protect other buildings, if possible—water curtains can be set up to help protect surrounding exposures but could place personnel within the blast radius of the hazard.

N G.11.8.2 Unique Challenges. Energy storage systems present a unique challenge for firefighters. Unlike a typical electrical or gas utility, an ESS does not have a single point of disconnect. There are disconnects that will deenergize select parts of the system, but batteries will remain energized.

The following hazards might be encountered when fighting fires in ESSs:

- (1) Shock or arcing hazard due to the presence of water during suppression activities
- (2) Related electrical enclosures might not resist water intrusion from the high-pressure stream of a fire hose
- (3) Batteries damaged in the fire might not resist water intrusion
- (4) Damaged conductors might not resist water intrusion

- (5) Shock hazard due to direct contact with energized components
- (6) No means of complete electrical disconnect due to stranded energy

Due to these hazards, care and consideration should be applied when considering fire suppression by means of water inundation within ESSs. But because water as an extinguisher is commonplace, the appropriate use of water as an extinguishing medium should be assessed (i.e., whether water reacts with the chemistries present or whether it is an appropriate extinguisher class).

NG.11.8.3 Potential Impact Radius. Explosion modeling has shown that the minimum distance should be 75 ft (23 m). It is recommended increasing that to a minimum clearance of 100 ft (30.5 m).

NG.11.8.4 Evacuate Area. Recommend evacuating buildings within a 200 ft (61 m) diameter of the battery energy storage system (BESS).

There is potential for damage to glass in windows and structure depending on distance from the site. Each hazard will be different based on the state of charge at the time of the event.

NG.11.8.5 Types of Hazards Once a Fire has Started. Fire, explosions, toxic gases, chemical hazards, CO, CO₂, hydrocarbons (i.e., typically propane and methane, but this depends on the chemistry of the specific battery), and H₂.

NG.11.8.6 Lithium-ion Battery Can Burn for Hours and Possible Days. The burn time for Li-ion batteries depends on battery chemistry, size, and state of charge.

Cells that remain hot pose a risk of gas generation leading to explosion, as well as a delayed ignition risk, whereby heat in the cell can transfer to undamaged adjacent cells or remaining active material and reignite the fire.

NG.11.8.7 Electrical Hazards.

NG.11.8.7.1 Stored Energy. Stored energy within the batteries can be an electrical hazard. When any battery fire is extinguished, there is still stranded energy within the unaffected cells that will need to be properly handled to reduce the risk of an additional fire hazard or electrical shock.

Some of the equipment (i.e., batteries) will remain energized no matter what actions are taken, and the recommended option is containment. Batteries remain energized even if all the contactors, breakers, and switches have been opened.

NG.11.8.7.2 Ignition—Stranded Energy. If the battery has reached the point of thermal runaway, suppression systems will only reduce the flammable risk. Once the suppression systems have released, if O₂ is introduced through remote venting or opening of access doors there is a risk of additional fire or explosion.

NG.11.9 Example Format for an Emergency Response Plan. Figure G.11.9 shows an example layout for formatting an emergency response plan.

EXAMPLE FORMAT FOR AN EMERGENCY RESPONSE PLAN

TABLE OF CONTENTS

1. Introduction	2
1.1 Purpose	2
1.2 Limitations	2
1.3 Facility Description	2
1.4 Plan Review and Revision	2
2. Emergency Response Management	2
2.1 Overall Organization	2
2.2 Roles and Responsibilities	2
2.3 Preparation and Planning for Emergencies	2
2.4 Communications	3
2.5 Operator Safety and Equipment	3
2.6 Safety Training	3
3. Emergency Response	4
3.1 Discovery	4
3.2 Initial Response/Notification Procedures	4
3.3 Sustained Actions	4
3.4 Post-Emergency Reporting Procedures	5
4. Fire Incidents	5
4.1 Conditions Associated with Energy Storage Systems	5
4.2 Response to a Fire Incident	6
4.3 Employee Training and Education	7
4.4 Site Maintenance and Housekeeping	8
5. Medical Emergency	8
5.1 Medical Emergency Response Procedures	8
5.2 Nonemergency Safety Incident	8
6. Security Incidents	9
6.1 Bomb Threat	9
6.2 Chemical/Biological Agent Threat	9
6.3 Sabotage or Vandalism	9
6.4 Active Shooter	9
7. Severe Weather	9
7.1 Flooding and Flash Floods	9
7.2 Tornado	9
7.3 Lightning Storm	9
8. Cybersecurity	9
Acronyms	9
Appendices	10
Appendix 1: Map of Site	10
Appendix 2: Referenced Titles and Roles	10
Appendix 3: Emergency Contacts	10
Appendix 4: Incident Report Form	11

Δ FIGURE G.11.9 Example Format for an Emergency Response Plan.

1 INTRODUCTION.

1.1 Purpose.

The following emergency response procedures are provided so that all [SITE NAME] personnel understand the practices that are to be followed to be prepared for and to provide quick and effective response to emergencies that might arise at the facility. Because the safety of employees is of primary concern, the [SITE NAME] O&M manager and each member of the [SITE NAME] staff are committed to providing a safe, healthy work environment and are responsible for ensuring implementation of these procedures.

1.2 Limitations.

This plan does not imply, nor should it infer or guarantee a perfect response will be practical or possible. No plan can shield individuals from all events.

Responders will attempt to coordinate the plan and response according to standards.

Every reasonable effort will be made to respond to emergencies, events, or disasters; however, personnel and resources could be overwhelmed.

There might be little to no warning during specific events to implement operational procedures.

The success or failure of all emergency plans depends upon effective tactical execution. Successful implementation of this plan depends on timely identification of capabilities, available resources at the time of the incident, and a thorough information exchange between responding organizations and the facility or transporter.

Each agency, facility, and jurisdiction will respond within the limits of their training, capabilities, and qualifications.

1.3 Facility Description.

[SITE NAME] is located in [CITY/COUNTY] at [ADDRESS].

The site is composed of [very brief description of equipment].

Appendix 1 provides a map of the facility. Notification information for plant and external support organizations (e.g., police, fire department, medical facilities, and so on) that can be called to respond to emergency situations at [SITE NAME] is included in Tables 1 and 2. Support personnel are available on the plant site from [TIMES].

The site manager is available via cellular phone in case of an emergency.

1.4 Plan Review and Revision.

A review of this emergency response plan (ERP) shall be conducted and documented at minimum on an annual basis. The plan will also be reviewed and amended whenever there is a change in facility design, construction, operation, or maintenance that affects emergency response planning.

2 EMERGENCY RESPONSE MANAGEMENT.

2.1 Overall Organization.

Overall responsibility for the ERP lies with the [SITE NAME] O&M manager. The O&M manager or lead technician is responsible for program implementation, including designating evacuation routes and employee assembly points, coordinating severe weather activities, communicating emergency response procedures to site personnel, contracting with emergency response organizations, and contractor coordination.

2.2 Roles and Responsibilities.

Specific management personnel will assume leadership roles for emergency responses. The site manager or lead technician will assist in the implementation of this plan by knowing and communicating evacuation routes to workers during emergency evacuation and reporting the status of the evacuation to the fire department. The O&M manager is responsible for seeing that this plan is implemented and will appoint an adequate number of personnel to enforce the plan, assure everyone is familiar with this plan, and act as a liaison with the local fire department(s).

All facility personnel have a responsibility to immediately report emergency situations to the lead technician on duty, who then notifies the O&M manager and other key personnel of the situation using the [SITE NAME] emergency contacts list (see Appendix 3). Where a lead technician is not assigned, facility personnel will refer to the emergency contact list to inform key personnel.

Titles and roles are summarized in Appendix 2.

2.3 Preparation and Planning for Emergencies.

2.3.1 Preplanning.

Preplanning for emergencies is a crucial element of this plan. The following steps have been taken in planning for emergency situations at the site:

- (1) All road exits have been established and posted in the [SITE NAME] O&M building.
- (2) Evacuation route diagrams have been documented and posted in the [O&M Building].
- (3) All buildings and property surrounded by fencing have been marked by signage that identifies specific hazards (e.g., the NFPA diamond, and all applicable danger, caution, warning signal words).

△ FIGURE G.11.9 *Continued*

- (4) Site personnel have received instruction to keep exits from the site or O&M building clear and to maintain ready access to fire extinguishers by not blocking them with furniture, or any other means.
- (5) The site O&M manager and lead technicians have been trained in their specific duties. All building occupants have been instructed in actions to take in case of an emergency through their copies of procedures and training, as needed.
- (6) A variety of emergency response drills (such as fire, tornado, bomb threat, and so on) have been held, at a minimum, on a quarterly basis, and have been documented. At least on an annual basis, the [locality] fire department and other emergency response personnel will be requested to participate and assist with critique of evacuation drills.

2.3.2 Emergency Routes.

A [SITE NAME] evacuation sheet must be posted and orally communicated to site personnel. These procedures shall be discussed at periodic safety meetings in addition to being covered during new employee orientation. Personnel are to know at least two exits whenever possible and be familiar with the evacuation routes posted in the O&M building.

Depending upon the degree of emergency, weather, or site conditions, roadways as designated on the site drawings (see Appendix 1) will be used for routes of evacuation. In the event of an evacuation, all personnel will meet at the designated muster point for further information. If personnel are unable to make it to the designated muster point, they should seek shelter wherever possible and contact their supervisor for further instructions.

2.3.3 Safety Data Sheets.

It is recommended to provide safety data sheets (SDS) to local first responders and stakeholders. In some cases, suppliers will provide material safety data sheets (MSDS) instead of SDS. They might be relevant, but it should be taken into account that MSDS sheets are meant for chemicals that the environment can be exposed to, which is not the case in most energy storage systems since they contain sealed components. Ventilation should not contaminate fresh air supplies to occupied spaces. Spill management should not contaminate freshwater drain pathways. Disposal of hazardous materials should comply with local and national rules and regulations. SDS and MSDS are generally available online.

2.4 Communications.

Timely and efficient communications are essential to deal with an emergency response situation. For that reason, the following requirements have been established at [SITE NAME].

Employees using radios/phones shall yield to individuals who are the most directly involved in an emergency response activity, (i.e., emergency response takes priority over all other communication on company network).

If radio/phone communications are interrupted or unclear, employees should proceed to the O&M building.

All hand-held radio/phones should be recharged daily with backup batteries ready for use.

Provisions shall be made for non-English-speaking workers on-site.

2.5 Operator Safety and Equipment.

2.5.1 General Recommendations for Operator Safety.

- (1) Inspect equipment daily for unsafe conditions
- (2) Keep hands away from exposed electrical connections
- (3) Keep hands away from hot surfaces
- (4) Observe all high-voltage warnings

2.5.2 Personal Protective Equipment.

The operation or maintenance of specific equipment can have different safety requirements. Always be aware of individual equipment operational requirements and hazards.

For example:

- (1) Safety glasses with side shields (no dark glasses are permitted except those approved for welding or cutting)
- (2) Face shields for cutting and grinding
- (3) Approved safety toe shoes
- (4) Approved hearing protection
- (5) Hardhat
- (6) Gloves
- (7) Long-sleeve shirts
- (8) Long pants

2.6 Safety Training.

Operator personnel should receive supplier- or manufacturer-approved training on the specific characteristics of the energy storage system. Applicable common standards (e.g., on electrical safety) should be taken into account.

A service manual that contains comprehensive information for carrying out maintenance activities should be provided for maintenance personnel. The service manual should provide energy-storage-specific safety instructions.

▲ FIGURE G.11.9 *Continued*

A local subject matter expert should be available in cases where substantial numbers of energy storage systems exist. This person should be readily available to first responders in the case of emergency situations. If this is not practical, a toll-free phone number should be available such that first responders can call at any time, and give operational data on the system, including its current state, and advise on how to proceed with the event.

All hazardous materials incident emergency responders and workers at hazardous materials facilities, transport companies, waste treatment facilities, storage facilities, and disposal facilities will be provided training that meets federal and state standards. Such training will be commensurate with their employer's or organization's plan and policies.

Initial and refresher training of the ERP to site personnel shall be conducted at least annually. Documentation of ERP training is to be maintained in site files.

3 EMERGENCY RESPONSE.

The phases of emergency response can be categorized as follows:

- (1) Discovery
- (2) Initial response/notification
- (3) Sustained actions
- (4) Termination and follow-up actions

3.1 Discovery.

Without entering an immediate hazard area, the employee who first discovers an emergency should identify the following:

- (1) Is there a fire, spill, or explosion?
- (2) Does medical assistance appear to be needed?
- (3) Who/what is at risk: people, property, or the environment?
- (4) Where does the released chemical appear to be migrating?
- (5) What are the weather and terrain conditions?

The employee will also isolate the area to keep people away from the scene until trained responders arrive, as long as it is safe to do so. An employee who has not received training in emergency response should take no actions beyond notification, isolation of the area, and personal safety precautions. Any efforts made to rescue persons, protect property, or protect the environment must be weighed against the possibility of becoming part of the problem. Persons at the scene must not walk or touch spilled material or inhale fumes, smoke, and vapors.

3.2 Initial Response/Notification Procedures.

The initial response phase starts with notification, which activates the emergency response system. Anyone who observes or receives information regarding an emergency at [SITE NAME] should immediately notify available personnel using the [SITE NAME] radio network or their issued cell phones. The O&M manager or lead technician will then ensure 911 is notified. At [SITE NAME], employees are notified of emergencies by cell phone/radio and word of mouth from the O&M manager or lead technician. Appendix 2 provides a list of emergency contact information for [SITE NAME] personnel.

If an event has the potential to impact the local community, [SITE NAME] will contact local fire/police to make community notifications. The contact list in Appendix 2 also provides notification information for the company public affairs team who will provide guidance for instances involving media. The O&M manager or lead technician will coordinate any media efforts through the [SITE NAME] asset manager and company legal department. Trained responders are called to the scene by the O&M manager or lead technician to begin the process of hazard assessment, establish objectives and priorities, implement a tactical plan, and mobilize resources.

Trained responders can enter the area only when wearing appropriate protective gear. Only trained responders are authorized to risk exposure to chemicals for containing or stopping the material release

The O&M manager is the designated emergency coordinator at [SITE NAME]; he or she or a designee will be responsible for notifying the appropriate regulatory agencies and, if necessary, the emergency response contractor or mutual aid groups. Appendix 2 includes a list of offsite emergency contacts and agencies that can be notified in the event of an emergency. The incident will be documented and kept on file.

3.3 Sustained Actions.

3.3.1

In the absence of the O&M manager acting as emergency coordinator, the lead technician assumes the lead as the emergency coordinator. In the event both the O&M manager and lead technician are absent, their designee will assume the role of emergency coordinator. The emergency coordinator takes control of the emergency and any resources necessary until the emergency has been eliminated and the necessary cleanup or restoration are complete.

The emergency coordinator will direct the following activities during the evaluation process:

- (1) Evaluate if operations in the affected area should be shut down
- (2) Take precautions to prevent or limit the spread of fire or explosions
- (3) Isolate affected area and provide direction for radio announcements
- (4) Determine the source/cause of the emergency and evaluate the primary and secondary hazards to allow a full-scale, safe response

▲ FIGURE G.11.9 Continued

- (5) Ensure that appropriate internal and external notifications are made
- (6) Coordinate outside assistance from public or private organizations
- (7) Implement other appropriate response provisions as necessary

Only employees that are properly trained in accordance with 29 CFR 1910.120(q)(6) can respond to chemical releases. No employee is required or permitted to place themselves in harm's way to facilitate extinguishment, evacuation, or rescue. All rescue operations will be performed by trained professionals upon their arrival.

3.3.2 Evacuation Procedures.

When notified to evacuate, site personnel shall do so in a calm and orderly fashion, keeping the following instructions in mind:

- (1) Walk, don't run—help others who need assistance
- (2) Drive safely through smoke, if you must
- (3) Watch for other traffic and farm equipment on access roads and roadways
- (4) Be aware of ice/snow and loose gravel conditions, drive safely

Site personnel shall go to the primary designated assembly area which is the O&M building. If employees are unable to make it to the assembly area, they should contact their supervisor for further instructions.

During evacuation, the O&M manager or lead technician should ensure that every person on his/her crew has been notified and that evacuation routes are clear. Any person with a disability (e.g., mobility, hearing, sight, and so on) who requires assistance to evacuate is responsible for prearranging with someone in their immediate work area to assist them in the event of an emergency. Anyone knowing of a person with a disability or injury who was not able to evacuate will report this fact immediately to their supervisor.

Once an evacuation is complete, the O&M manager or lead technician should account for all personnel.

3.4 Post-Emergency Reporting Procedures.

Following any emergency described in this plan, and in compliance with facility permits and other county or state requirements, an incident report will be prepared by the O&M manager and transmitted to the appropriate individuals and agencies after review by the company regional manager.

The O&M manager shall compile all documentation and perform a post-accident investigation. Immediate performance of this activity will aid in determining the exact circumstances and cause of the incident.

Issues to be determined include the following:

- (1) Causes of the incident
- (2) Effectiveness of the ERP
- (3) Need for amendments to the response plan
- (4) Need for additional training programs

4 FIRE INCIDENTS.

All staff working at [Site Name] are to be trained and should know how to prevent and respond to a fire emergency. All on-site staff shall:

- (1) Complete an on-site training program identifying the fire risks at [Site Name]
- (2) Understand the protocol and follow emergency procedures should an event occur
- (3) Review and report potential fire hazards to the O&M managers

No employee is required or permitted to place themselves in harm's way to facilitate extinguishment, evacuation, or rescue. All rescue operations will be performed by trained professionals upon their arrival.

4.1 Conditions Associated with Energy Storage Systems.

4.1.1 Unique Challenges.

Energy storage systems present a unique challenge for firefighters. Unlike a typical electrical or gas utility, an energy storage system does not have a single point of disconnect. Whereas there are disconnects that will deenergize select parts of the system, batteries will remain energized.

The following hazards might be encountered when fighting fires in energy storage systems:

- (1) Shock or arcing hazard due to the presence of water during suppression activities
- (2) Related electrical enclosures might not resist water intrusion from the high-pressure stream of a fire hose
- (3) Batteries damaged in the fire might not resist water intrusion
- (4) Damaged conductors might not resist water intrusion
- (5) Shock hazard due to direct contact with energized components
- (6) No means of complete electrical disconnect

4.1.2 Fire and Water.

Due to the hazards described in 4.1.1, care and consideration should be applied when considering fire suppression by means of water inundation within energy storage systems. But because water as an extinguisher is commonplace, the appropriate use of water as an extinguishing medium should be assessed (i.e., whether water reacts with the chemistries present or whether it is not an appropriate extinguisher class).

If unconventional fire extinguishers are required, local first responders should be alerted and trained on their use. The appropriate and most suitable extinguisher should be recommended based on the specific needs of the site. This might include water in some cases, and in all scenarios its use should not be discouraged.

If an energy storage system is enclosed, a means to connect water extinguishers to the exterior to activate interior sprinkler heads might be a requirement. First responders should be trained on this procedure. This is only applicable if water is deemed as an appropriate extinguisher.

4.2 Response to a Fire Incident.

Each storage unit/container is equipped with fire detection and suppression systems. They are continuously monitored for smoke detection and are set up for alarm system notifications.

In the event of an incipient stage (i.e., beginning, small) fire, employees should notify adjacent individuals of this situation and exit the area. Only employees trained in the use of fire extinguishers should attempt to use an extinguisher. Employees are not expected or authorized to respond to fires beyond the incipient stage (i.e., fires that are beyond the beginning stage and which cannot be extinguished using a hand-held, portable fire extinguisher). If necessary, the fire department should be immediately notified by dialing 911.

Site management shall also be immediately notified of any emergency.

4.2.1 Fire External to Battery Container.

For fires external to the battery container:

- (1) Make sure the immediate area of the fire is clear of personnel.
- (2) Account for all employees, contractors, and visitors who were working in the area of the fire.
- (3) Contact the O&M manager (if present) and emergency response coordinator (if not the O&M manager) immediately.
- (4) Call 911 and report the following:
 - a. Site name: [Site Name]
 - b. The address of the main entrance: [ADDRESS] or nearest site access point
 - c. Injuries, if any, and need for ambulance
- (5) Remove any obstructions (e.g., vehicles, materials) that might impede response to the scene.
- (6) Station available personnel at road intersections to stop traffic flow into the fire scene.
- (7) Evacuate the energy storage system area immediately if the fire-warning alarm sounds or fire-warning lights illuminate.
- (8) Proceed to the designated muster point for head count.
 - (a) If onsite, the designated emergency response coordinator will do a head count and relay any information/instructions.
- (9) If you encounter heavy smoke, stay low and breath through a handkerchief or other fabric; move away from the area.
- (10) Assist anyone having trouble leaving the area.
- (11) Attempt to extinguish the fire only if you have had the appropriate training and proper firefighting agent for the type of fire. Refer to the specific safety data sheet.
- (12) Do not leave the designated muster point until advised to do so.
- (13) The O&M manager will issue an 'all clear' only when the fire department informs them that it is safe to do so.
- (14) The energy storage system is not to be accessed until the O&M manager or designated emergency response coordinator gives authorization.

4.2.2 Fire Internal to Battery Container.

For fires internal to the battery container:

- (1) Make sure the immediate area of the fire is clear of personnel.
- (2) Account for all employees, contractors, and visitors who were working in the area of the fire.
- (3) Contact the O&M manager (if present) and emergency response coordinator (if not the O&M manager) immediately.
- (4) Contact the operations center and manager (if present).
- (5) Evacuate the area immediately if the fire-warning alarm sounds or fire-warning lights illuminate.
- (6) Account for all employees, contractors, and visitors who were working in the area of the fire.
- (7) Call 911 and report the following:
 - a. Site name: [Site Name]
 - b. The address of the main entrance: [ADDRESS] or nearest site access point
 - c. Injuries, if any, and need for ambulance
- (8) Remove any obstructions (e.g., vehicles, materials) that might impede response to the scene.
- (9) Proceed to the designated muster point for head count.
 - (a) If onsite, the designated emergency response coordinator will do a head count and relay any information/instructions.
- (10) If you encounter heavy smoke, stay low and breath through a handkerchief or other fabric.
- (11) Assist anyone having trouble leaving the area.

▲ FIGURE G.11.9 *Continued*

- (12) The fire suppression system is designed to work in a contained environment. Do not open the doors until it has been determined that the agent has been fully released and a predetermined amount of time has passed to ensure no hazards are present.
- (13) *Do not* put anyone in harm's way to save the battery equipment in the container.
- (14) Once the fire department arrives, provide them with the following:
 - (a) All applicable SDS documents
 - (b) Assistance isolating equipment electrically
- (15) Do not leave the designated muster point until advised to do so.
- (16) The O&M manager will issue an 'all clear' only when the fire department informs them that it is safe to do so.
- (17) The energy storage system is not to be accessed until the O&M manager or designated emergency response coordinator gives authorization.

In the event of a fire incident, the designated operations personnel responsible for the safe shutdown of the plant will open switchgear to ensure the grid side of the plant is deenergized and isolate the batteries as best able to (i.e., verify the AC and DC breakers are open in the inverter). The fire department needs to understand that some of the equipment (e.g., batteries) will remain energized no matter what actions are taken, and the recommended option is containment. Batteries remain energized even if all the contactors, breakers, and switches have been opened.

4.2.3 After a Fire.

Hazards after a fire should be identified at the time of installation such that recommendations for personal protective equipment (PPE) are available for clean-up crews and hazardous materials (HAZMAT) teams. This can include respirators to protect personnel from toxic gas that continues to be generated from hot cells. Firewater retention and cleanup measures might be required by local regulations.

In addition to the gas generation risk, cells that remain hot also pose a delayed ignition risk, whereby heat in the cell might transfer to undamaged adjacent cells or remaining active material and reignite the fire.

4.2.4 Inverter Fires.

In the event of an inverter fire at [SITE NAME]:

- (1) Make sure the immediate area of the fire is clear of personnel.
- (2) Account for all employees, contractors, and visitors who were working in the area of the fire.
- (3) Remove any obstructions (e.g., vehicles, materials) that might impede response to the scene.
- (4) Station available personnel at road intersections to stop traffic flow into the fire scene.
- (5) Contact the operations center and site manager (if present) immediately.
- (6) *Do not* attempt to extinguish fire near electrical equipment with water or other chemicals as an electric shock or arc could occur.
- (7) Call 911 and report the following:
 - (a) Site Name: [SITE NAME]
 - (b) The address of the main entrance: [ADDRESS] or nearest site access point
 - (c) Injuries if any, and need for ambulance
- (8) A designated O&M employee shall meet firefighters at the project site entrance and direct them to the location of the fire.
- (9) If possible, O&M staff shall safely attempt to shut down power at the inverter using the DC disconnect.
- (10) O&M staff protect surrounding areas from flying embers with fire extinguishers.
- (11) Provide safety data sheets (SDS) for the skid if needed.
- (12) The O&M manager will issue an 'all clear' only when the fire department informs them that it is safe to do so.

4.3 Employee Training and Education.

Fire procedures are to be posted at the project site on a bulletin board along with the OSHA compliance postings, first aid, and site-specific project information. The bulletin board is to be located at the O&M building located on-site.

O&M staff shall be trained in the practices of fire prevention relevant to their duties. O&M staff shall be trained and equipped to extinguish small fires to prevent them from growing into more serious threats. Staff must understand the function and elements of potential emergencies, reporting procedures, evacuation plans, and shutdown procedures. Review any special hazards that might occur at [SITE NAME], such as flammable materials, fuel storage, toxic chemicals, and water reactive substances.

Fire safety training will occur during the site safety training. O&M staff are required to undergo training prior to starting work.

Training shall include the following:

- (1) Employee roles and responsibilities
- (2) Recognition of potential fire hazards
- (3) Alarm system and evacuation routes
- (4) Location and operation of manually operated equipment (e.g., fire extinguishers)
- (5) Emergency response procedures
- (6) Emergency shutdown procedures
- (7) Information regarding specific materials to which employees might be exposed
- (8) Review OSHA requirements contained in 29 CFR 1910.38

▲ FIGURE G.11.9 *Continued*

- (9) Review OSHA requirements contained in 29 CFR 1910.39
 - (10) The location of the company fire protection plan and how it can be accessed
 - (11) Good fire-prevention housekeeping practices and equipment maintenance
- The O&M managers are responsible for fire safety training. Written documentation of the training received by each employee must be maintained.

4.4 Site Maintenance and Housekeeping.

Maintenance and housekeeping should include the following:

- (1) Fire extinguishers shall be inspected monthly.
- (2) Fire extinguishers shall not be obstructed and should be in conspicuous locations.
- (3) Combustible material shall not be stored in mechanical rooms, electrical equipment rooms, or the SCADA buildings.
- (4) Outside dumpsters shall be kept at least five (5) feet away from combustible materials and the lid should be kept closed.
- (5) Storage is not allowed in electrical equipment rooms, or near electrical panels.
- (6) Electrical panel openings must be covered.
- (7) Power strips must be plugged directly into an outlet and not daisy-chained and should be for temporary use only.
- (8) Extension cords and flexible cords should not be substituted for permanent.

5 MEDICAL EMERGENCY.

5.1 Medical Emergency Response Procedures.

If an employee is injured, or an accident has occurred on-site and first aid is not enough treatment for the emergency, 911 must be called. The call to 911 can be made by phone by any available site personnel. The caller must state to the dispatch that they are at the "[Company [SITE NAME]]." A second notification will be made to the O&M building, to inform others of the situation.

All [SITE NAME] employees are to be certified in first aid/cardiopulmonary resuscitation (CPR) and can administer aid if they have completed training. An automated external defibrillator (AED) is stored at the O&M building and each service truck which should be utilized as necessary.

5.1.1 Serious Injury.

The following procedures apply for serious medical injuries such as loss of consciousness, heart attack, bone fractures, neck trauma, or severe burns:

- (1) Notify operations or safety managers.
- (2) If life threatening, call 911.
- (3) Provide name, exact location, number of injured persons, and brief description of incident.
- (4) On-site personnel shall meet EMS responders at site entrance and direct them to location of incident.
- (5) Do not leave or move the injured unless directed to by safety managers or EMS responders.
- (6) Administer first aid if necessary.
- (7) Document incident and keep on file.

5.1.2 Attending an Incident.

When attending an incident, the following procedures apply:

- (1) Clear a path to the injured person for operations or safety managers and assign personnel to assist with signaling EMS responders to the location of the incident.
- (2) Identify location of project site entrance nearest to the incident and notify EMS responders.
- (3) Operations or safety managers shall meet EMS responders at site entrance.
- (4) Direct and accompany EMS responders to location of incident.
- (5) Follow all directions of EMS responders.
- (6) Contact management staff or subcontractors.
- (7) Document incident and keep on file.

5.1.3 Medical Facilities.

The nearest medical facility to the project site is: [HOSPITAL ADDRESS]

Directions from site entrance: [Turn-by-turn directions, and link to online map directions]

5.2 Nonemergency Safety Incident.

5.2.1 Notification of Minor Incidents.

In the event a safety incident occurs where emergency response is not required (e.g., first aid treatment, near miss, and so on) work is to be stopped immediately and reported to the O&M manager or lead technician. Risk will be reassessed, adequate controls implemented, and the situation made safe before resuming the task. The event will be documented and kept on file.

▲ FIGURE G.11.9 *Continued*

5.2.2 Heat Illness.

When the temperature exceeds 95°F (35°C), or is expected to be so during the course of a shift or work project, the O&M manger will hold short staff meetings to review the weather report; reinforce heat illness prevention with all workers; and provide reminders to drink water frequently, to be on the lookout for signs and symptoms of heat illness, and inform them that shade can be made available upon request.

Employees shall have free access to potable drinking water provided and located as close as practicable to the areas where employees are working. Where drinking water is not plumbed or otherwise continuously supplied, it shall be provided in sufficient quantity at the beginning of the work shift to provide one quart per employee per hour for drinking for the entire shift. Employers can begin the shift with smaller quantities of water if they have effective procedures for replenishment during the shift as needed to allow employees to drink one quart or more per hour. The frequent drinking of water shall be encouraged.

6 SECURITY INCIDENTS. (Not included, add as appropriate.)

6.1 Bomb Threat.

6.2 Chemical/Biological Agent Threat.

6.3 Sabotage or Vandalism.

6.4 Active Shooter.

7 SEVERE WEATHER. (Not included, add as appropriate.)

7.1 Flooding and Flash Floods.

7.2 Tornado.

7.3 Lighting Storm.

8 CYBERSECURITY. (Not included, add as appropriate.)

Acronyms

AED	automated external defibrillator
CHEMTREC	chemical shipping regulation and incident support
CPR	cardiopulmonary resuscitation
DHS	Department of Homeland Security
EMS	emergency medical services
ERP	emergency response plan
HAZMAT	hazardous materials
ICS	incident command system
MSDS	material safety data sheets
NFPA	National Fire Protection Association
NRC	National Response Center (U.S. EPA)
OSHA	Occupational Safety and Health Administration
O&M	operations and maintenance
PPE	personal protective equipment
SCADA	supervisory control and data acquisition
SDS	safety data sheets

▲ FIGURE G.11.9 *Continued*

APPENDICES

Appendix 1: Map of Site.

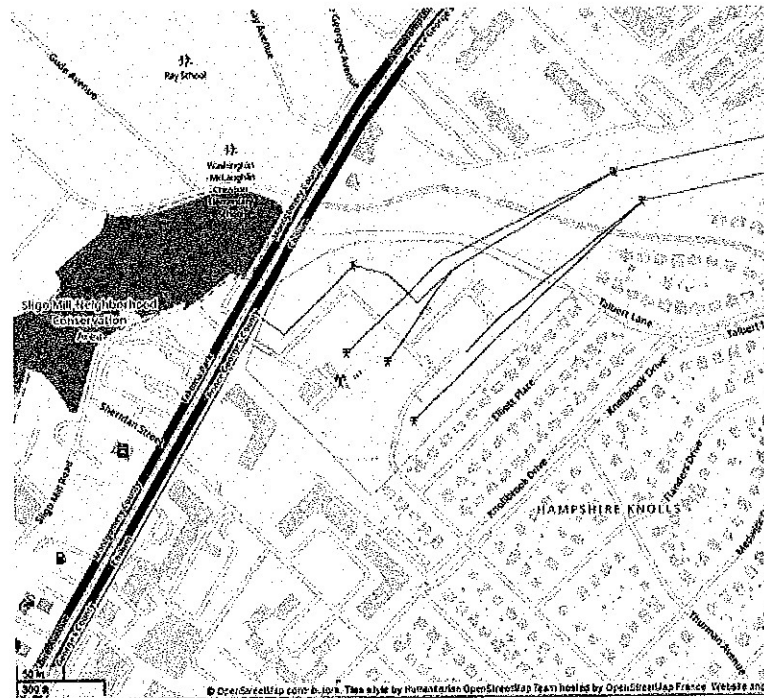

(To include site boundaries, primary and secondary entrances, O&M building.)

Appendix 2: Referenced Titles and Roles.

Company regional manager: [role] O&M manager: [role]
 Emergency response contractor: [role] Lead technician: [role]
 Emergency response coordinator: [role] Site manager: [role]

Appendix 3: Emergency Contacts.

Title	Individual	Telephone number
O&M manager / Emergency coordinator	Name	Office: (999) 999-9999 Cell: (999) 999-9994
Site safety representative	Name	Cell: (999) 999-3411
Lead technician	Name	Cell: (999) 999-7624
Alternate emergency contact	Name	Cell: (999) 999-9699
Company regional manager	Name	Office: (999) 999-9999 Cell: (999) 991-9999
Company asset manager	Name	Office: (999) 999-9999
Company control center	Operator on duty	Cell: (999) 992-1999

▲ FIGURE G.11.9 Continued

Organization	Telephone Number
<i>Offsite Emergency Assistance</i> Fire/Police/Ambulance State Police Hospital Memorial Health Center, 1000 Road Crossing, Townsville, JK 99999	911 911 999-999-9999
<i>Emergency Spill Response Contractor</i> Construction and Response Co. Townsville, JK	999-888-3999
<i>Agency Notifications</i> NRC (24-hour) (report oil spills) State Department of Public Health and Environment	800-999-9999 877-999-9999
<i>Additional Assistance</i> Sheriff's Department State Poison and Drug Center	911 800-999-9999

Appendix 4: Incident Report Form.**HAZARDOUS MATERIALS INCIDENT REPORT****INITIAL CONTACT INFORMATION**

(Check one): Reported/actual incident _____ Drill/exercise _____

1. Date/time of notification: _____ Report received by: _____

2. Reported by (name and phone number or radio call signs): _____

3. Company/agency and position (if applicable): _____

4. Incident address/descriptive location: _____

5. Agencies at the scene: _____

6. Known damage/casualties (do not provide names over unsecured communications): _____

CHEMICAL INFORMATION7. Nature of emergency (check all that apply): Leak Explosion Spill Fire Derailment Other
Description: _____

8. Name of material(s) released/placard number(s): _____

9. Release of materials:

_____ Has ended _____ Is continuing. Estimated release rate and duration: _____

▲ FIGURE G.11.9 Continued

10. Estimated amount of material which *has been* released: _____
11. Estimated amount of material which *could be* released: _____
12. Media into which the release occurred: Air Ground Water
13. Plume characteristics:
- a. Direction (compass direction of plume): _____ c. Color: _____
- b. Height of plume: _____ d. Odor: _____
14. Characteristics of material (e.g., color, smell, liquid, gaseous, solid) _____
15. Present status of material (i.e., solid, liquid, or gas): _____
16. Apparently responsible party or parties: _____
- _____
- _____

ENVIRONMENTAL CONDITIONS

17. Current weather conditions at incident site:
- Wind from: _____ Wind speed (mph): _____ Temperature (F): _____
- Humidity (%): _____ Precipitation: _____ Visibility: _____
18. Forecast: _____
19. Terrain conditions: _____

HAZARD INFORMATION — (from ERG, MSDS, CHEMTREC, or facility)

20. Potential hazards: _____
- _____
21. Potential health effects: _____
- _____
22. Safety recommendations: _____
- _____
23. Recommended evacuation distance: _____
- _____

IMPACT DATA

24. Estimated areas/populations at risk: _____
- _____
25. Special facilities at risk: _____
- _____
26. Other facilities with HAZMAT in area of incident: _____
- _____

PROTECTIVE ACTION DECISIONS

27. Tools used for formulating protective actions
- _____ a. Recommendations by facility operator/responsible party
- _____ b. *Emergency Response Guidebook*
- _____ c. Material safety data sheet
- _____ d. Recommendations by CHEMTREC
- _____ e. Results of incident modeling (CAMEO or similar software)
- _____ f. Other: _____

Δ FIGURE G.11.9 *Continued*

28. Protective action recommendations:

_____ Evacuation _____ Shelter-in-place _____ Combination _____ No action
_____ Other _____

Time	Actions Implemented

29. Evacuation routes recommended: _____

EXTERNAL NOTIFICATIONS

30. Notification made to:

_____ National Response Center (federal spill reporting)	<u>1-800-999-9999</u>
_____ CHEMTREC (hazardous materials information)	<u>1-800-999-9999</u>
_____ RRC (Oil/gas spills—production facilities, intrastate pipelines)	_____
_____ State emergency response commission	_____

31. Other Information: _____

Δ FIGURE G.11.9 Continued

Annex H Informational References

H.1 Referenced Publications. The documents or portions thereof listed in this annex are referenced within the informational sections of this standard and are not part of the requirements of this document unless also listed in Chapter 2 for other reasons.

H.1.1 NFPA Publications. National Fire Protection Association, 1 Batterymarch Park, Quincy, MA 02169-7471.

NFPA 1, *Fire Code*, 2021 edition.

NFPA 10, *Standard for Portable Fire Extinguishers*, 2022 edition.

NFPA 12, *Standard on Carbon Dioxide Extinguishing Systems*, 2022 edition.

NFPA 12A, *Standard on Halon 1301 Fire Extinguishing Systems*, 2022 edition.

NFPA 13, *Standard for the Installation of Sprinkler Systems*, 2022 edition.

NFPA 14, *Standard for the Installation of Standpipe and Hose Systems*, 2019 edition.

NFPA 15, *Standard for Water Spray Fixed Systems for Fire Protection*, 2022 edition.

NFPA 17, *Standard for Dry Chemical Extinguishing Systems*, 2021 edition.

NFPA 22, *Standard for Water Tanks for Private Fire Protection*, 2018 edition.

NFPA 24, *Standard for the Installation of Private Fire Service Mains and Their Appurtenances*, 2022 edition.

NFPA 25, *Standard for the Inspection, Testing, and Maintenance of Water-Based Fire Protection Systems*, 2023 edition.

NFPA 68, *Standard on Explosion Protection by Deflagration Venting*, 2018 edition.

NFPA 69, *Standard on Explosion Prevention Systems*, 2019 edition.

NFPA 70[®], *National Electrical Code*[®], 2023 edition.

NFPA 70B, *Recommended Practice for Electrical Equipment Maintenance*, 2022 edition.

NFPA 70E[®], *Standard for Electrical Safety in the Workplace*[®], 2021 edition.

NFPA 72[®], *National Fire Alarm and Signaling Code*[®], 2022 edition.

NFPA 76, *Standard for the Fire Protection of Telecommunications Facilities*, 2020 edition.

NFPA 80, *Standard for Fire Doors and Other Opening Protectives*, 2022 edition.

NFPA 90A, *Standard for the Installation of Air-Conditioning and Ventilating Systems*, 2021 edition.

NFPA 101[®], *Life Safety Code*[®], 2021 edition.

NFPA 110, *Standard for Emergency and Standby Power Systems*, 2022 edition.

NFPA 111, *Standard on Stored Electrical Energy Emergency and Standby Power Systems*, 2022 edition.

NFPA 204, *Standard for Smoke and Heat Venting*, 2021 edition.

NFPA 400, *Hazardous Materials Code*, 2022 edition.

NFPA 497, *Recommended Practice for the Classification of Flammable Liquids, Gases, or Vapors and of Hazardous (Classified) Locations for Electrical Installations in Chemical Process Areas*, 2021 edition.

NFPA 499, *Recommended Practice for the Classification of Combustible Dusts and of Hazardous (Classified) Locations for Electrical Installations in Chemical Process Areas*, 2021 edition.

NFPA 550, *Guide to the Fire Safety Concepts Tree*, 2022 edition.

NFPA 551, *Guide for the Evaluation of Fire Risk Assessments*, 2022 edition.

NFPA 652, *Standard on the Fundamentals of Combustible Dust*, 2019 edition.

NFPA 704, *Standard System for the Identification of the Hazards of Materials for Emergency Response*, 2022 edition.

NFPA 750, *Standard on Water Mist Fire Protection Systems*, 2023 edition.

NFPA 805, *Performance-Based Standard for Fire Protection for Light Water Reactor Electric Generating Plants*, 2020 edition.

NFPA 850, *Recommended Practice for Fire Protection for Electric Generating Plants and High Voltage Direct Current Converter Stations*, 2020 edition.

NFPA 921, *Guide for Fire and Explosion Investigations*, 2021 edition.

NFPA 1221, *Standard for the Installation, Maintenance, and Use of Emergency Services Communications Systems*, 2019 edition.

NFPA 1620, *Standard for Pre-Incident Planning*, 2020 edition.

NFPA 1962, *Standard for the Care, Use, Inspection, Service Testing, and Replacement of Fire Hose, Couplings, Nozzles, and Fire Hose Appliances*, 2018 edition.

NFPA 2001, *Standard on Clean Agent Fire Extinguishing Systems*, 2022 edition.

NFPA 2010, *Standard for Fixed Aerosol Fire-Extinguishing Systems*, 2020 edition.

Fire Protection Handbook, 20th edition, 2008.

H.1.2 Other Publications.

H.1.2.1 CENELEC Publications. CENELEC, European Committee for Electrotechnical Standardization, CENELEC Management Centre, Rue de la Science 23, B - 1040 Brussels, Belgium.

EN 15276-1, *Fixed firefighting systems — Condensed aerosol extinguishing systems — Part 1: Requirements and test methods for components*, 2019.

EN 15276-2, *Fixed firefighting systems — Condensed aerosol extinguishing systems — Part 2: Design, installation and maintenance*, 2019.

N H.1.2.2 CSA Group Publications. CSA Group, 178 Rexdale Blvd., Toronto, ON M9W 1R3, Canada.

CAN/CSA C22.2 No. 107.1, *Power conversion equipment*, 2016, reaffirmed 2021.

CAN/CSA C22.2 No. 62109-1, *Safety of power converters for use in photovoltaic power systems — Part 1: General requirements*, 2016, reaffirmed 2021.

H.1.2.3 FPRF Publications. Fire Protection Research Foundation, 1 Batterymarch Park, Quincy, MA 02169-7471.

Best Practices for Emergency Response to Incidents Involving Electric Vehicles Battery Hazards: A Report on Full-Scale Testing Results, July 2013.

N H.1.2.4 ICC Publications. International Code Council, 500 New Jersey Avenue, NW, 6th Floor, Washington, DC 20001.

Uniform Fire Code, 1997.

H.1.2.5 IEC Publications. International Electrotechnical Commission, 3, rue de Varembe, P.O. Box 131, CH-1211 Geneva 20, Switzerland.

IEC 60812, *Analysis techniques for system reliability — Procedure for failure mode and effects analysis (FMEA)*, 2006.

IEC 61025, *Fault tree analysis (FTA)*, 2006.

H.1.2.6 IEEE Publications. IEEE, 3 Park Avenue, 17th Floor, New York, NY 10016-5997.

IEEE 450, *Recommended Practice for Maintenance, Testing, and Replacement of Vented Lead-Acid Batteries for Stationary Applications*, 2010.

IEEE 484, *IEEE Recommended Practice for Installation Design and Installation of Vented Lead-Acid Batteries for Stationary Applications*, 2019.

IEEE 1187, *Recommended Practice for Installation Design and Installation of Valve-Regulated Lead-Acid Batteries for Stationary Applications*, 2013.

IEEE 1188, *IEEE Recommended Practice for Maintenance, Testing, and Replacement of Valve-Regulated Lead-Acid (VRLA) Batteries for Stationary Applications*, 2005.

IEEE 1547, *Standard for Interconnection and Interoperability of Distributed Energy Resources with Associated Electric Power Systems Interfaces*, 2018.

IEEE 1635/ASHRAE 21, *Guide for the Ventilation and Thermal Management of Batteries for Stationary Applications*, 2018.

IEEE 3007.1, *Recommended Practice for the Operation and Management of Industrial and Commercial Power Systems*, 2010.

IEEE C2, *National Electrical Safety Code*, 2017.

N H.1.2.7 ISO Publications. International Organization for Standardization, ISO Central Secretariat, BIBC II, Chemin de Blandonnet 8, CP 401 - 1214 Vernier, Geneva, Switzerland.

ISO 9001, *Quality management systems — Requirements*, 2015.

H.1.2.8 Military Specifications. Department of Defense Single Stock Point, Document Automation and Production Service, Building 4/D, 700 Robbins Avenue, Philadelphia, PA 19111-5094.

MIL-STD-1629A, *Procedures for Performing a Failure Mode, Effects and Criticality Analysis*, 1980.

H.1.2.9 NECA Publications. National Electrical Contractors Association, 3 Bethesda Metro Center, Suite 1100, Bethesda, MD 20814.

NECA 416, *Recommended Practice for Installing Energy Storage Systems (ESS)*, 2017.

N H.1.2.10 SFPE Publications. Society of Fire Protection Engineers, 9711 Washingtonian Blvd., Suite 380, Gaithersburg, MD 20878.

SFPE Engineering Guide to Fire Risk Assessment, 2006.

SFPE Handbook of Fire Protection Engineering, 2016.

Δ H.1.2.11 UL Publications. Underwriters Laboratories Inc., 333 Pfingsten Road, Northbrook, IL 60062-2096.

UL 1012, *Power Units Other Than Class 2*, 2021.

UL 1642, *Lithium Batteries*, 2020.

UL 1741, *Inverters, Converters, Controllers and Interconnection System Equipment for Use With Distributed Energy Resources*, 2018.

UL 1778, *Uninterruptible Power Systems*, 2017.

UL 1973, *Batteries for Use in Stationary, Vehicle Auxiliary Power and Light Electric Rail (LER) Applications*, 2018.

UL 1974, *Evaluation for Repurposing Batteries*, 2018.

UL 2436, *Outline of Investigation for Spill Containment for Stationary Acid and Alkaline Electrolyte Battery Systems*, 2020.

ANSI/UL 2775, *Standard for Fixed Condensed Aerosol Extinguishing System Units*, 2019.

UL 62109-1, *Safety of Power Converters for Use in Photovoltaic Power Systems — Part 1: General Requirements*, 2019.

UL 9540, *Energy Storage Systems and Equipment*, 2020.

UL 9540A, *Test Method for Evaluating Thermal Runaway Fire Propagation in Battery Energy Storage Systems*, 2019.

H.1.2.12 UN Publications. United Nations Headquarters, 760 United Nations Plaza, New York, NY 10017.

UN 38.3, *Recommendations on the Transport of Dangerous Goods: Lithium Metal and Lithium Ion Batteries*, 2015.

UN 2800, *Batteries, wet, non-spillable, electric storage*, 2017.

N H.1.2.13 US Government Publications. US Government Publishing Office, 732 North Capitol Street, NW, Washington, DC 20401-0001.

Title 29, Code of Federal Regulations, Part 1910.38, "Emergency Action Plans."

Title 29, Code of Federal Regulations, Part 1910.39 "Fire Prevention Plans."

Title 29, Code of Federal Regulations, Part 1910.120(q)(6), "Hazardous Waste Operations and Emergency Response—Emergency Response to Hazardous Substance Releases—Training."

Title 29, Code of Federal Regulations, Part 1910.147, "The Control of Hazardous Energy (Lockout/Tagout)."

Title 29, Code of Federal Regulations, Part 1910.269(d), "Electric Power Generation, Transmission, and Distribution — Hazardous Energy Control (Lockout/Tagout) Procedures."

Δ H.1.2.14 Other Publications.

N H.1.2.14.1 References for Annex D.

1. International Electrotechnical Commission (IEC), "Electrical Energy Storage," White Paper, Geneva/Switzerland, pp. 17–34, December 2011.

2. Rastler, D., "Electricity Energy Storage Technology Option," Electric Power Research Institute, December 2010.

3. Doetsch, C., "Electrical energy storage from 100 kW—State of the art technologies, fields of use," 2nd International Renewable Energy Storage Conference, Bonn, Germany, November 2007.

4. Xie, S., and L. S. Wang, "Industry Trends — Issue 9," China Energy Storage Alliance, January 2012.

5. The ADELE project in Germany uses adiabatic compression, while the SustainX, General Compression, and LightSail projects in the US use isothermal compression. See "ADELE — Adiabatic Compressed-Air Energy Storage (CAES) for Electricity Supply," RWE; "SustainX's ICAES," SustainX; and "General Compression, Who We Are," General Compression.

6. Nakhmkin, M., "Novel Compressed Air Energy Storage Concepts," developed by Energy Storage and Power Consultants (ESPC) and presented to EESAT, May 2007.

7. Inage, Shin-ichi, "Prospects for Large-Scale Energy Storage in Decarbonised Grids," International Energy Agency, Report, 2009.

8. Schossig, P., "Thermal Energy Storage," 3rd International Renewable Energy Storage Conference, Berlin, Germany, November 2012.

9. Fairley, P., <http://spectrum.ieee.org/energy/environment/largest-solar-thermal-storage-plant-to-start-up>, Article 2008, Accessed July 2011.

10. Jahnig D, et al., "Thermo-chemical storage for solar space heating in a single-family house," 10th International Conference on Thermal Energy Storage, Ecstock 2006, New Jersey, May/June 2006.

11. Tamme, R., "Development of Storage Systems for SP Plants," DG TREN—DG RTD Consultative Seminar on Concentrating Solar Power, Brussels, Belgium, June 2006.

12. Bullough, C., "Advanced Adiabatic Compressed Air Energy Storage for the Integration of Wind Energy," European Wind Energy Conference and Exhibition, London, GB, November 2004.

H.1.2.14.2 References for Annex F.

H.1.2.14.2.1 NFPA Publications. National Fire Protection Association, 1 Batterymarch Park, Quincy, MA 02169-7471.

NFPA 1, *Fire Code*, 2000, 2003, 2006, 2009, 2012, 2015, and 2018 editions.

NFPA 853, *Standard for the Installation of Stationary Fuel Cell Power Systems*, 2015 edition.

"Lithium Ion Batteries Hazard and Use Assessment," Fire Protection Research Foundation, July 2011.

"Lithium Ion Batteries Hazard and Use Assessment — Phase IIB — Flammability Characterization of Li-ion Batteries for Storage Protection," Fire Protection Research Foundation, April 2013.

"Lithium Ion Batteries Hazard and Use Assessment — Phase III," Fire Protection Research Foundation, November 2016.

H.1.2.14.2.2 ICG Publications. International Code Council, 500 New Jersey Avenue, NW, 6th Floor, Washington, DC 20001.

International Building Code (IBC), 2000, 2003, 2009, 2012, and 2015.

International Fire Code (IFC), 2000, 2003, 2006, 2009, 2012, 2015, and 2018.

International Residential Code, 2018.

Uniform Fire Code (UFC), 1994 and 1997.

H.1.2.14.2.3 UL Publications. Underwriters Laboratories Inc., 333 Pfingsten Road, Northbrook, IL 60062-2096.

UL 9540A, *Test Method for Evaluating Thermal Runaway Fire Propagation in Battery Energy Storage Systems*, 2021.

N H.1.2.14.3 Other Publications. DNVGL Battery Safety Joint Development Project Report, "Technical Reference for Li-ion Battery Explosion Risk and Fire Suppression," January 7, 2020.

Marioff Corporation—Fire Test Summary #57/BR/AUG15, "HI-FOG® Systems for Protection of Li-ion Rooms," August 2015.

"Fire Safety Testing Data Analysis Supplement for NYC Outdoor ESS," NY Solar Map, City University of New York (CUNY). https://nysolarmap.com/media/2041/fire-safety-testing-data-analysis-supplement-for-nyc-outdoor-ess_v1.pdf

H.2 Informational References. (Reserved)

H.3 References for Extracts in Informational Sections.

NFPA 1, *Fire Code*, 2009 edition.

NFPA 13D, *Standard for the Installation of Sprinkler Systems in One- and Two-Family Dwellings and Manufactured Homes*, 2022 edition.

NFPA 70®, *National Electrical Code®*, 2023 edition.

NFPA 101®, *Life Safety Code®*, 2021 edition.

Index

Copyright © 2022 National Fire Protection Association. All Rights Reserved.

The copyright in this index is separate and distinct from the copyright in the document that it indexes. The licensing provisions set forth for the document are not applicable to this index. This index may not be reproduced in whole or in part by any means without the express written permission of NFPA.

-A-**Administration**, Chap. 1

- Application, 1.3, A.1.3
- Equivalency, 1.5, A.1.5
- Purpose, 1.2
- Retroactivity, 1.4
- Scope, 1.1, A.1.1
- Units and Formulas, 1.6

Apartment Building

- Definition, 3.3.1, A.3.3.1

Approved

- Definition, 3.2.1, A.3.2.1

Authority Having Jurisdiction (AHJ)

- Definition, 3.2.2, A.3.2.2

-B-**Battery**

- Definition, 3.3.2
- Flow Battery
 - Definition, 3.3.2.1, A.3.3.2.1

Battery Energy Storage System Hazards, Annex B

- Commercially Available Battery Technologies, B.5
 - Flow Batteries — General Description, B.5.1
 - Vanadium Redox Flow Batteries, B.5.1.1
 - Zinc Air Flow Batteries, B.5.1.3
 - Zinc Bromine (ZnBr) Flow Batteries, B.5.1.2
 - High-Temperature Batteries—General Description, B.5.7
 - Liquid Metal Battery—General, B.5.7.2
 - Sodium Batteries, High-Temperature — General Description, B.5.7.1
 - Sodium Nickel Chloride Batteries, B.5.7.1.2
 - Sodium Sulfur (Na-S) Batteries, B.5.7.1.1
 - Lead-Acid Batteries — General Description, B.5.2
 - Valve-Regulated Lead-Acid (VRLA) Batteries, B.5.2.2
 - Vented Lead-Acid (VLA) Batteries, B.5.2.1
 - Lithium Ion (Li-ion) Batteries — General Description, B.5.3
 - Lithium Iron Phosphate (LFP), B.5.3.3
 - Lithium Nickel Cobalt Aluminum (NCA) Oxide, B.5.3.1
 - Lithium Nickel Manganese Cobalt (NMC) Oxide, B.5.3.2
 - Lithium Metal, Solid State Batteries — General Description, B.5.4
 - Nickel Batteries — General Description, B.5.5
 - Nickel-Cadmium (Ni-Cd) and Nickel-Zinc (Ni-Zn) Batteries, B.5.5.1
 - Nickel-Metal Hydride (Ni-MH) Batteries, B.5.5.2
 - Sodium Batteries, Aqueous — General Description, B.5.6
- General Introduction, B.1
- Hazard Considerations Under Emergency/Abnormal Conditions, B.4
 - Chemical Hazards, B.4.2
 - Electrical Hazards, B.4.3
 - Fire Hazards, B.4.1
 - Physical Hazards, B.4.4
- Hazard Considerations Under Normal Operating Conditions, B.3
 - Chemical Hazards, B.3.2
 - Electrical Hazards, B.3.3
 - Fire and Explosive Hazards, B.3.1
 - Physical Hazards, B.3.4
- Hazards Concerns, B.2
- Other Technologies, B.6
 - Electrochemical Double-Layer Capacitors — General, B.6.1

Battery Management System (BMS)

- Definition, 3.3.3, A.3.3.3

-C-**Cell**

- Definition, 3.3.4

Commissioning, Chap. 6

- Operations and Maintenance Documentation, 6.3
- Recommissioning of Existing Systems, 6.4, A.6.4
- System Commissioning, 6.1
 - Commissioning Plan, 6.1.3
 - Commissioning Report, 6.1.5
 - Corrective Action Plan, 6.1.5.3
 - Commissioning Test, 6.1.4

-D-**Decommissioning**, Chap. 8

- Decommissioning Plan, 8.1
- Decommissioning Process, 8.2
- Decommissioning Report, 8.3

Definitions, Chap. 3**Dwelling Unit**

- Definition, 3.3.5
 - One- and Two-Family Dwelling Unit
 - Definition, 3.3.5.1, A.3.3.5.1
 - One-Family Dwelling Unit
 - Definition, 3.3.5.2
 - Two-Family Dwelling Unit
 - Definition, 3.3.5.3

-E-**Electric Utilities**

- Definition, 3.3.6

Electrochemical Double Layer Capacitor (EDLC)

- Definition, 3.3.7, A.3.3.7

Electrochemical Energy Storage Systems, Chap. 9

- Equipment, 9.2
 - Energy Storage Management System (ESMS), 9.2.3

- Lead-Acid and Nickel-Cadmium Battery Systems, 9.2.3.4
 - HMA for Existing Lithium-Ion ESS, 9.2.2
 - Listing, 9.2.1
 - Lead-Acid and Nickel-Cadmium Battery Systems, 9.2.1.2
 - Repurposed and Refurbished Batteries, 9.2.4
 - General, 9.1
 - Fire and Explosion Testing, 9.1.5
 - Test Reports, 9.1.5.2, A.9.1.5.2
 - Installation, 9.4
 - Maximum Stored Energy, 9.4.1
 - Size and Separation, 9.4.2, A.9.4.2
 - Lead-Acid and Nickel-Cadmium Battery Systems, 9.4.2.4
 - Location and Applications, 9.5
 - Indoor Installations, 9.5.1
 - ESS Dedicated Use Buildings, 9.5.1.1
 - Non-Dedicated-Use Buildings, 9.5.1.2
 - Dwelling Units and Sleeping Units, 9.5.1.2.2
 - Occupied Work Centers, 9.5.1.2.1, A.9.5.1.2.1
 - Outdoor Installations, 9.5.2
 - HMA, 9.5.2.1
 - Locations Near Exposures, 9.5.2.6
 - Clearance to Exposures, 9.5.2.6.1
 - ESS Exhaust Outlets, 9.5.2.6.1.6
 - Exterior Wall Installations, 9.5.2.6.1.8
 - Means of Egress Separation, 9.5.2.6.1.7
 - Maximum Size, 9.5.2.4
 - Remote Locations, 9.5.2.5
 - Vegetation Control, 9.5.2.2
 - Walk-in Units, 9.5.2.3
 - Specific Outdoor Locations, 9.5.3
 - Mobile ESS Equipment and Operations, 9.5.3.2
 - Approved Locations, 9.5.3.2.3
 - Charging and Storage, 9.5.3.2.1
 - Charging and Storage Requirements, 9.5.3.2.5
 - Deployed Mobile ESS Requirements, 9.5.3.2.6
 - Clearance to Exposures, 9.5.3.2.6.6
 - Deployment Documents, 9.5.3.2.6.1
 - Duration, 9.5.3.2.6.5
 - Electrical Connections, 9.5.3.2.6.7
 - Fencing, 9.5.3.2.6.8
 - Fire Suppression Connections, 9.5.3.2.6.4
 - Restricted Locations, 9.5.3.2.6.2
 - Wheeled Vehicles, 9.5.3.2.6.3
 - Deployment, 9.5.3.2.2
 - Local Staging, 9.5.3.2.4
 - Rooftop and Open Parking Garage Installations, 9.5.3.1
 - Clearance to Exposures, 9.5.3.1.3
 - Fire Suppression and Control, 9.5.3.1.4
 - Open Parking Garages, 9.5.3.1.2
 - Rooftop Installations, 9.5.3.1.1
 - Location Classification, 9.3
 - Indoor Installations, 9.3.1
 - Energy Storage System (ESS) Dedicated-Use Buildings, 9.3.1.1
 - Non-Dedicated-Use Buildings, 9.3.1.2
 - Outdoor Installations, 9.3.2
 - Protection and Remediation, 9.6
 - Fire Barriers, 9.6.4
 - Fire Control and Suppression, 9.6.2
 - Lead-Acid and Nickel-Cadmium Battery Systems, 9.6.2.2
 - Remediation Measures, 9.6.6
 - Authorized Service Personnel, 9.6.6.1, A.9.6.6.1
 - Hazard Support Personnel, 9.6.6.2, A.9.6.6.2
 - Smoke and Fire Detection, 9.6.1
 - Technology-Specific Requirements, 9.6.5
 - Exhaust Ventilation During Normal Operation, 9.6.5.1, A.9.6.5.1
 - Abnormal Conditions, 9.6.5.1.2
 - Indoor ESS Cabinets, 9.6.5.1.3
 - Mechanical Exhaust Ventilation, 9.6.5.1.5
 - Natural Exhaust Ventilation, 9.6.5.1.4, A.9.6.5.1.4
 - Ni-MH Batteries, 9.6.5.1.1
 - Explosion Control, 9.6.5.6, A.9.6.5.6
 - Neutralization, 9.6.5.3
 - Safety Caps, 9.6.5.4, A.9.6.5.4
 - Spill Control, 9.6.5.2
 - Thermal Runaway Protection, 9.6.5.5, A.9.6.5.5
 - Water Supply, 9.6.3
 - Lead-Acid and Nickel-Cadmium Systems, 9.6.3.2
- Energy Storage Management System (ESMS)**
 - Definition, 3.3.8, A.3.3.8
- Energy Storage Systems (ESS)**
 - Capacitor Energy Storage System
 - Definition, 3.3.9.1
 - Definition, 3.3.9, A.3.3.9
 - Energy Storage System (ESS) Dedicated-Use Building
 - Definition, 3.3.9.3
 - Energy Storage System Cabinet
 - Definition, 3.3.9.2
 - Energy Storage System Walk-In Unit
 - Definition, 3.3.9.4
 - Mobile Energy Storage System
 - Definition, 3.3.9.5
 - Portable Energy Storage System
 - Definition, 3.3.9.6
 - Stationary Energy Storage System
 - Definition, 3.3.9.7
- Explanatory Material, Annex A**

-F-

Fire and Building Codes — A Short History on Stationary Storage Battery Systems, Annex F

- General, F.1
- Historical Development of Codes, F.2
 - 1997 Uniform Fire Code, F.2.1
 - 2000 International Code Council Codes, F.2.2
 - 2003 International Code Council Codes and NFPA 1, Fire Code, F.2.3
 - 2006 International Code Council Codes and NFPA 1, Fire Code, F.2.4
 - 2009 International Code Council Codes and NFPA 1, Fire Code, F.2.5
 - 2012 and 2015 International Code Council Codes and NFPA 1, Fire Code, F.2.6

- 2018 International Code Council Codes and NFPA 1, Fire Code, F.2.7
 - 2021 International Code Council Code Development and 2019 NFPA 855, Standard for the Installation of Stationary Energy Storage Systems, F.2.8
 - NFPA Fire Protection Research Foundation, F.3
 - Fire and Explosion Testing**
 - Definition, 3.3.10
 - Fire Area**
 - Definition, 3.3.11
 - Fire Command Center**
 - Definition, 3.3.12
 - Firefighting Considerations (Operations), Annex C**
 - Air Monitoring, C.6
 - Emergency Response to ESS Incidents, C.4
 - Fires, C.4.2
 - Overheated Batteries, C.4.1
 - Fire Detection and Suppression, C.7
 - Fire Detection, C.7.1
 - Passive Fire Control, C.7.2
 - Suppression Tactics, C.7.3
 - Flooding and Seismic Influences, C.8
 - General, C.2
 - Overview, C.1
 - Emergency Responder Pre-incident Planning, C.1.1
 - Suppressing Agent Choice Considerations, C.5
 - Flow Batteries, C.5.3
 - Lead-Acid, Nickel-Cadmium, and Other Aqueous Battery Technologies, C.5.2
 - Lithium-Ion (Li-ion) Batteries, C.5.1
 - Sodium Sulfur (NaS) Batteries, C.5.4
 - Suppression Systems, C.3
 - Flywheel Energy Storage System (FESS)**
 - Braking
 - Definition, 3.3.13.1, A.3.3.13.1
 - Definition, 3.3.13, A.3.3.13
 - Spin Down
 - Definition, 3.3.13.2, A.3.3.13.2
 - Standby FESS
 - Definition, 3.3.13.3
 - Flywheel Energy Storage Systems (FESS), Chap. 13**
 - Application, 13.1
 - Commissioning, 13.3, A.13.3
 - Decommissioning, 13.5
 - Operation and Maintenance, 13.4, A.13.4
 - Spin Down, 13.4.3
 - Protection Features, 13.2
 - Fuel Cell Energy Storage Systems, Chap. 11**
 - Fuel-Cell-Powered Vehicle Use, 11.2
 - Installation and Maintenance, 11.1
- G-**
- General, Chap. 4**
 - Combustible Storage, 4.5
 - Construction Documents, 4.2
 - Building Owner, 4.2.2
 - Commissioning Plan, 4.2.4
 - General, 4.2.1
 - Manuals, 4.2.3
 - Emergency Planning and Training, 4.3
 - Facility Staff Planning and Training, 4.3.2
 - Emergency Operations Plan, 4.3.2.1
 - Facility Staff Training, 4.3.2.2
 - General, 4.3.1, A.4.3.1
 - Equipment, 4.6
 - Charge Controllers, 4.6.8
 - Enclosures, 4.6.12
 - Energy Storage Management System (ESMS), 4.6.10, A.4.6.10
 - Environment, 4.6.7
 - ESS Toxic and Highly Toxic Gas Release During Normal Use, 4.6.11, A.4.6.11
 - Increase in Power Rating or Maximum Stored Energy, 4.6.6
 - Inverters and Converters, 4.6.9
 - Listings, 4.6.1, A.4.6.1
 - Repairs, 4.6.2
 - Replacements, 4.6.4
 - Retrofits, 4.6.3
 - Reused Equipment, 4.6.5
 - Fire Control and Suppression, 4.9
 - Alternate Automatic Fire Control and Suppression Systems, 4.9.3
 - Sprinkler System, 4.9.2
 - Water Supply, 4.9.4
 - General, 4.1, A.4.1
 - Hazard Mitigation Analysis (HMA), 4.4
 - Failure Modes, 4.4.2
 - Installation, 4.7
 - Access Roads, 4.7.11
 - Design Loads, 4.7.3
 - Electrical Installation, 4.7.1, A.4.7.1
 - Elevation, 4.7.7
 - Belowgrade Installations, 4.7.7.1
 - Fire Barriers, 4.7.13
 - Fire Command Centers, 4.7.10
 - Hazardous (Classified) Locations, 4.7.12, A.4.7.12
 - Impact Protection, 4.7.5
 - Means of Egress, 4.7.8
 - Open Rack Installations, 4.7.9
 - Security of Installations, 4.7.6
 - Seismic Protection, 4.7.2
 - Signage, 4.7.4, A.4.7.4
 - Mobile ESS Equipment and Operations, 4.10
 - Smoke and Fire Detection, 4.8
 - Annunciation, 4.8.2
 - Guide for Suppression and Safety of Lithium-Ion Battery (LIB) Energy Storage Systems (ESS), Annex G**
 - Fire and Flammable Gas Detection, Including the Location, Type, and Purpose for Available Technologies, G.7
 - Battery Management System Safety Functions, G.7.4
 - Design and Installation, G.7.2
 - Detection Systems, G.7.3
 - Aspirating Smoke Detection (ASD), G.7.3.7
 - High-Risk Equipment Protection, G.7.3.7.2
 - Localized Protection (Cabinets), G.7.3.7.1
 - BMS, G.7.3.1

- Flame Detection, G.7.3.3
- Gas Detection, G.7.3.6
 - Cell-Level Event, G.7.3.6.1
 - Effects on H₂ Gas Detection After Suppression Discharge, G.7.3.6.3
 - Installation Level Event, G.7.3.6.2
- Heat Detection, G.7.3.4
- Smoke Detection, G.7.3.2
- Thermal Imaging—Temperature Monitoring and Early Warning Fire Detection, G.7.3.5
- Video Detection, G.7.3.8
 - Video Image Smoke Detection (VISD), G.7.3.8.1
- Electrical Disconnects, G.7.6
- ESS Rack, G.7.7
 - Ground-Fault Protection, G.7.7.1
 - Overcurrent Protection, G.7.7.2
 - Voltage Protection, G.7.7.3
- General, G.7.1
- Online Condition Monitoring, G.7.5
- Fire Protections Systems and Mitigation Strategies, Including System Goal, Water Duration, and Water Application Strategies, G.6
- Standpipes, G.6.3
- Suppression Technologies, G.6.1
 - Aerosols, G.6.1.6
 - Design and Installation, G.6.1.6.3
 - Inspection, Testing, and Maintenance, G.6.1.6.5
 - Listing, G.6.1.6.2
 - Standards, G.6.1.6.1
 - Testing, G.6.1.6.4
 - Clean Agents, G.6.1.4
 - Design and Installation, G.6.1.4.1
 - Sprinklers, G.6.1.1
 - Water Mist Systems, G.6.1.3
 - Design and Installation, G.6.1.3.4
 - Different Types of Water Mist Systems, G.6.1.3.1
 - Fire and Explosion Test Report References for Li-Ion Battery Fire Suppression with Water Mist, G.6.1.3.3
 - Testing, G.6.1.3.3.1
 - Inspection, Testing, and Maintenance, G.6.1.3.5
 - Standards, G.6.1.3.2
- Fundamentals of Hazards Associated with LIB-Based ESS, G.2
 - Chemical Hazards, G.2.3
 - Electrical Hazards, G.2.4
 - Fire and Explosion Hazards, G.2.2
 - Hazards General, G.2.1
 - Lithium-Ion Battery Hazards, G.2.6
 - Physical Hazards, G.2.5
- General, G.1
 - Hazard Communication, G.1.4
 - Electrical Hazards, G.1.4.3
 - General, G.1.4.1
 - Signs and Placards, G.1.4.2
 - Thermal Runaway Hazards, G.1.4.4
 - Minimum Installation Information, G.1.3
 - Purpose, G.1.2
 - Scope, G.1.1
- Guidance on Developing a First Responder Plan for LIB-Based ESS Installations, G.11
 - Emergency Responder Pre-incident and Emergency Operation Planning, G.11.2
 - Example Format for an Emergency Response Plan, G.11.9
 - Fire Detection and Suppression, G.11.7
 - Emergency Response to ESS Incidents, G.11.7.5
 - Fire Detection, G.11.7.1
 - Flooding and Seismic Influences, G.11.7.4
 - Passive Fire Control, G.11.7.2
 - Suppression Tactics, G.11.7.3
 - Guidelines, G.11.3
 - Overheated Batteries, G.11.5
 - Overview, G.11.1
 - Site Access and Conditions First Responder Hazards, G.11.8
 - Electrical Hazards, G.11.8.7
 - Ignition—Stranded Energy, G.11.8.7.2
 - Stored Energy, G.11.8.7.1
 - Evacuate Area, G.11.8.4
 - Lithium-ion Battery Can Burn for Hours and Possible Days, G.11.8.6
 - Potential Impact Radius, G.11.8.3
 - Types of Hazards Once a Fire has Started, G.11.8.5
 - Unique Challenges, G.11.8.2
 - Upon Arrival, G.11.8.1
 - Suppressing Agent Choice Considerations, G.11.6
 - Suppression Systems, G.11.4
- Guidance on Inspection and Maintenance for Installed LIB Fire Protection Systems, G.10
 - Decommissioning, G.10.5
 - General, G.10.1
 - Impairments, G.10.4
 - Lockout/Tagout, G.10.3
 - Record Keeping, G.10.6
 - Safety Training, G.10.7
 - Inspection/Audit Checklists, G.10.7.3
 - Testing, Inspection, and Maintenance, G.10.2
- Hazards and Risks Posed by ESS with Hazard Mitigation Analysis (HMA) and Fire Risk Assessment (FRA), G.3
 - Common HMA and FRA Concepts Related to ESS, G.3.6
 - Fire and Explosion Protection Design Basis Process, G.3.4
 - Fire Protection HMA or FRA (Deliverables), G.3.5
 - General, G.3.1
 - Inputs to the HMA Process, G.3.3
 - General Inputs, G.3.3.1
 - Project-Specific Inputs, G.3.3.2
 - Stakeholders, G.3.2
- Known Failure Modes and Their Associated Consequences and Mitigation Approaches (Bowtie Analysis), G.4
 - Bowtie and Hazard Mitigation Analysis Overview, G.4.1
 - Consequences, G.4.3
 - Individual Pathways, G.4.3.1
 - Individual Barriers, G.4.3.1.1
 - Emergency Action Plan/First Responders, G.4.3.1.1.6
 - Exhaust Ventilation, G.4.3.1.1.4
 - Facility Design and Siting, G.4.3.1.1.9
 - Fire Service Response, G.4.3.1.1.7

- Fire, Smoke, Heat, and Failure
 - Detection, G.4.3.1.1.1
 - Gas Phase Suppression System, G.4.3.1.1.3
 - Situational Awareness, G.4.3.1.1.2
 - Thermal Isolation/Cascading Protection, G.4.3.1.1.8
 - Water-Based Suppression System, G.4.3.1.1.5
 - Threats, G.4.2
 - Active Monitoring, Controls and Electrical Protections, G.4.2.4
 - BMS Control, G.4.2.4.3
 - Inverter/PCS Controls, G.4.2.4.5
 - Redundant Failure Detection/System Intelligence, G.4.2.4.2
 - System Electrical Abuse Tolerance, G.4.2.4.6
 - System Shutdown/Disconnect, G.4.2.4.1
 - Voltage Monitoring, G.4.2.4.4
 - Individual Barriers, G.4.2.2
 - Cell-Level Failures and Protections, G.4.2.2.1
 - Active Cell Protection, G.4.2.2.1.2
 - Cell Electrical Abuse Tolerance, G.4.2.2.1.5
 - Cell Quality Control, G.4.2.2.1.4
 - Cell Thermal Abuse Tolerance, G.4.2.2.1.3
 - Passive Cell Protections, G.4.2.2.1.1
 - Individual Pathways, G.4.2.1
 - Multicell Thermal Runaway Causes, G.4.2.1.2
 - Single-Cell Thermal Runaway, G.4.2.1.1
 - Passive Physical and Electrical Protections, G.4.2.3
 - Passive Circuit Protection and Design, G.4.2.3.1
 - System Shutdown/Disconnect, G.4.2.3.2
 - LIB Construction and Installation Guidance, G.9
 - Dedicated ESS Building or Enclosure Larger Than 500 ft² (46.5 m²), G.9.3
 - Damage-Limiting Construction (DLC), G.9.3.3
 - Mechanical Ventilation, G.9.3.4
 - ESS Cutoff Rooms, G.9.4
 - ESS Enclosures, G.9.2
 - General Location and Construction, G.9.1
- H-**
- Hazard Mitigation Analysis (HMA)**
 - Definition, 3.3.14
- I-**
- Informational References, Annex H**
- L-**
- Labeled**
 - Definition, 3.2.3
 - Listed**
 - Definition, 3.2.4, A.3.2.4
 - Living Area**
 - Definition, 3.3.15
- M-**
- Maximum Stored Energy**
 - Definition, 3.3.16
- O-**
- Off-Gassing**
 - Definition, 3.3.17
 - Off-Specification Battery or Cell**
 - Definition, 3.3.18
 - One- and Two-Family Dwellings and Townhouse Units, Chap. 15**
 - Electric Vehicle Use, 15.11
 - Electrical Installation, 15.6
 - Energy Ratings, 15.5
 - Equipment Listings, 15.2
 - ESS Toxic and Highly Toxic Gas Release During Normal Use, 15.10
 - Exhaust Ventilation, 15.9
 - Fire Detection, 15.7
 - General, 15.1, A.15.1
 - Installation, 15.3
 - ESS Spacing, 15.3.1
 - Labeling, 15.3.2
 - Locations, 15.4
 - Protection from Impact, 15.8
 - Open Parking Garage**
 - Definition, 3.3.19
 - Operation and Maintenance, Chap. 7**
 - System Maintenance, 7.2, A.7.2
 - Training, 7.2.5
 - System Operation, 7.1
 - Electric Utilities Under NERC Jurisdiction, 7.1.1
 - SDS for Hazardous Materials, 7.1.3
 - System Testing, 7.3
 - Overview of Energy Storage Systems Technologies, Annex D**
 - Electrical ESS, D.4
 - Superconducting Magnetic Energy Storage (SMES), D.4.1
 - Introduction, D.1
 - Mechanical ESS, D.3
 - Compressed Air Energy Storage (CAES), D.3.2
 - Flywheel Energy Storage (FES), D.3.3
 - Pumped Hydroelectric Storage (PHS), D.3.1
 - Technical Comparison and Future Potential for ESS, D.2
 - Thermal Energy Storage, D.5
- P-**
- Permits, Inspections, Approvals, and Connections, Annex E**
 - Connection to an Energy Supply, E.3
 - Authorization, E.3.1
 - Temporary Consideration, E.3.2
 - Inspections and Approvals, E.2
 - Application, E.2.1
 - Concealment, E.2.3
 - Inspection, E.2.2
 - Reinspection, E.2.4
 - Revocation of Permits, E.2.5
 - Permits, E.1
 - Application, E.1.1
 - Content, E.1.2
 - Issuance of Permits, E.1.3
 - Revocation of Permits, E.1.4

	-Q-		
Qualified Person			Metal Drums, 14.3.2.3
Definition, 3.3.20			Prefabricated Portable Structure, 14.3.2.2
			Rooms or Spaces, 14.3.2.1
	-R-		Outdoor Storage Location, 14.6
Recycle			Weather Protection, 14.6.3
Definition, 3.3.21			Prevention and Mitigation, 14.4
Referenced Publications, Chap. 2			Stored-Energy Emergency Power Supply System (SEPSS)
Repurposed Battery			Definition, 3.3.25
Definition, 3.3.22, A.3.3.22			System Interconnections, Chap. 5
			Disconnecting Means, 5.2
			General, 5.1
	-S-		Nonelectrical Systems, 5.3
Shall			Biogas, 5.3.5
Definition, 3.2.5			Compressed Natural Gas (CNG), 5.3.2
Standard			Hydrogen Fuel Systems and Storage, 5.3.4
Definition, 3.2.6			Liquefied Petroleum Gas (LP-Gas) Systems and Storage, 5.3.3
Standby Power Application			Liquid Fuels, 5.3.6
Definition, 3.3.23			Natural Gas, 5.3.1
Storage of Batteries			Water, 5.3.7
Definition, 3.3.24			Support Systems, 5.4, A.5.4
Storage of Lithium Metal or Lithium-ion Batteries, Chap. 14			
Batteries, 14.1			-T-
Collection Locations, 14.2			Thermal Runaway
Explosion Protection, 14.5			Definition, 3.3.26, A.3.3.26
Deflagration Potential, 14.5.1			
Indoor Storage Locations, 14.3			-U-
General, 14.3.1			Utility Interactive
Storage Methods, 14.3.2			Definition, 3.3.27
Containers Approved for Transportation, 14.3.2.4			

Sequence of Events for the Standards Development Process

Once the current edition is published, a Standard is opened for Public Input.

Step 1 – Input Stage

- Input accepted from the public or other committees for consideration to develop the First Draft
- Technical Committee holds First Draft Meeting to revise Standard (23 weeks); Technical Committee(s) with Correlating Committee (10 weeks)
- Technical Committee ballots on First Draft (12 weeks); Technical Committee(s) with Correlating Committee (11 weeks)
- Correlating Committee First Draft Meeting (9 weeks)
- Correlating Committee ballots on First Draft (5 weeks)
- First Draft Report posted on the document information page

Step 2 – Comment Stage

- Public Comments accepted on First Draft (10 weeks) following posting of First Draft Report
- If Standard does not receive Public Comments and the Technical Committee chooses not to hold a Second Draft meeting, the Standard becomes a Consent Standard and is sent directly to the Standards Council for issuance (see Step 4) or
- Technical Committee holds Second Draft Meeting (21 weeks); Technical Committee(s) with Correlating Committee (7 weeks)
- Technical Committee ballots on Second Draft (11 weeks); Technical Committee(s) with Correlating Committee (10 weeks)
- Correlating Committee Second Draft Meeting (9 weeks)
- Correlating Committee ballots on Second Draft (8 weeks)
- Second Draft Report posted on the document information page

Step 3 – NFPA Technical Meeting

- Notice of Intent to Make a Motion (NITMAM) accepted (5 weeks) following the posting of Second Draft Report
- NITMAMs are reviewed and valid motions are certified by the Motions Committee for presentation at the NFPA Technical Meeting
- NFPA membership meets each June at the NFPA Technical Meeting to act on Standards with “Certified Amending Motions” (certified NITMAMs)
- Committee(s) vote on any successful amendments to the Technical Committee Reports made by the NFPA membership at the NFPA Technical Meeting

Step 4 – Council Appeals and Issuance of Standard

- Notification of intent to file an appeal to the Standards Council on Technical Meeting action must be filed within 20 days of the NFPA Technical Meeting
- Standards Council decides, based on all evidence, whether to issue the standard or to take other action

Notes:

1. Time periods are approximate; refer to published schedules for actual dates.
2. Annual revision cycle documents with certified amending motions take approximately 101 weeks to complete.
3. Fall revision cycle documents receiving certified amending motions take approximately 141 weeks to complete.

Committee Membership Classifications^{1,2,3,4}

The following classifications apply to Committee members and represent their principal interest in the activity of the Committee.

1. M *Manufacturer*: A representative of a maker or marketer of a product, assembly, or system, or portion thereof, that is affected by the standard.
2. U *User*: A representative of an entity that is subject to the provisions of the standard or that voluntarily uses the standard.
3. IM *Installer/Maintainer*: A representative of an entity that is in the business of installing or maintaining a product, assembly, or system affected by the standard.
4. L *Labor*: A labor representative or employee concerned with safety in the workplace.
5. RT *Applied Research/Testing Laboratory*: A representative of an independent testing laboratory or independent applied research organization that promulgates and/or enforces standards.
6. E *Enforcing Authority*: A representative of an agency or an organization that promulgates and/or enforces standards.
7. I *Insurance*: A representative of an insurance company, broker, agent, bureau, or inspection agency.
8. C *Consumer*: A person who is or represents the ultimate purchaser of a product, system, or service affected by the standard, but who is not included in (2).
9. SE *Special Expert*: A person not representing (1) through (8) and who has special expertise in the scope of the standard or portion thereof.

NOTE 1: “Standard” connotes code, standard, recommended practice, or guide.

NOTE 2: A representative includes an employee.

NOTE 3: While these classifications will be used by the Standards Council to achieve a balance for Technical Committees, the Standards Council may determine that new classifications of member or unique interests need representation in order to foster the best possible Committee deliberations on any project. In this connection, the Standards Council may make such appointments as it deems appropriate in the public interest, such as the classification of “Utilities” in the National Electrical Code Committee.

NOTE 4: Representatives of subsidiaries of any group are generally considered to have the same classification as the parent organization.

Submitting Public Input / Public Comment Through the Online Submission System

Following publication of the current edition of an NFPA standard, the development of the next edition begins and the standard is open for Public Input.

Submit a Public Input

NFPA accepts Public Input on documents through our online submission system at www.nfpa.org. To use the online submission system:







- Choose a document from the List of NFPA codes & standards or filter by Development Stage for “codes accepting public input.”
- Once you are on the document page, select the “Next Edition” tab.
- Choose the link “The next edition of this standard is now open for Public Input.” You will be asked to sign in or create a free online account with NFPA before using this system.
- Follow the online instructions to submit your Public Input (see www.nfpa.org/publicinput for detailed instructions).
- Once a Public Input is saved or submitted in the system, it can be located on the “My Profile” page by selecting the “My Public Inputs/Comments/NITMAMs” section.

Submit a Public Comment

Once the First Draft Report becomes available there is a Public Comment period. Any objections or further related changes to the content of the First Draft must be submitted at the Comment Stage. To submit a Public Comment follow the same steps as previously explained for the submission of Public Input.

Other Resources Available on the Document Information Pages

Header: View document title and scope, access to our codes and standards or NFCSS subscription, and sign up to receive email alerts.

 Current & Prior Editions	Research current and previous edition information.
 Next Edition	Follow the committee’s progress in the processing of a standard in its next revision cycle.
 Technical Committee	View current committee rosters or apply to a committee.
 Ask a Technical Question	For members, officials, and AHJs to submit standards questions to NFPA staff. Our Technical Questions Service provides a convenient way to receive timely and consistent technical assistance when you need to know more about NFPA standards relevant to your work.
 News	Provides links to available articles and research and statistical reports related to our standards.
 Purchase Products & Training	Discover and purchase the latest products and training.
 Related Products	View related publications, training, and other resources available for purchase.

Information on the NFPA Standards Development Process

I. Applicable Regulations. The primary rules governing the processing of NFPA standards (codes, standards, recommended practices, and guides) are the NFPA *Regulations Governing the Development of NFPA Standards (Regs)*. Other applicable rules include NFPA *Bylaws*, NFPA *Technical Meeting Convention Rules*, NFPA *Guide for the Conduct of Participants in the NFPA Standards Development Process*, and the NFPA *Regulations Governing Petitions to the Board of Directors from Decisions of the Standards Council*. Most of these rules and regulations are contained in the *NFPA Standards Directory*. For copies of the *Directory*, contact Codes and Standards Administration at NFPA headquarters; all these documents are also available on the NFPA website at "www.nfpa.org/regs."

The following is general information on the NFPA process. All participants, however, should refer to the actual rules and regulations for a full understanding of this process and for the criteria that govern participation.

II. Technical Committee Report. The Technical Committee Report is defined as "the Report of the responsible Committee(s), in accordance with the Regulations, in preparation of a new or revised NFPA Standard." The Technical Committee Report is in two parts and consists of the First Draft Report and the Second Draft Report. (See *Regs* at Section 1.4.)

III. Step 1: First Draft Report. The First Draft Report is defined as "Part one of the Technical Committee Report, which documents the Input Stage." The First Draft Report consists of the First Draft, Public Input, Committee Input, Committee and Correlating Committee Statements, Correlating Notes, and Ballot Statements. (See *Regs* at 4.2.5.2 and Section 4.3.) Any objection to an action in the First Draft Report must be raised through the filing of an appropriate Comment for consideration in the Second Draft Report or the objection will be considered resolved. [See *Regs* at 4.3.1(b).]

IV. Step 2: Second Draft Report. The Second Draft Report is defined as "Part two of the Technical Committee Report, which documents the Comment Stage." The Second Draft Report consists of the Second Draft, Public Comments with corresponding Committee Actions and Committee Statements, Correlating Notes and their respective Committee Statements, Committee Comments, Correlating Revisions, and Ballot Statements. (See *Regs* at 4.2.5.2 and Section 4.4.) The First Draft Report and the Second Draft Report together constitute the Technical Committee Report. Any outstanding objection following the Second Draft Report must be raised through an appropriate Amending Motion at the NFPA Technical Meeting or the objection will be considered resolved. [See *Regs* at 4.4.1(b).]

V. Step 3a: Action at NFPA Technical Meeting. Following the publication of the Second Draft Report, there is a period during which those wishing to make proper Amending Motions on the Technical Committee Reports must signal their intention by submitting a Notice of Intent to Make a Motion (NITMAM). (See *Regs* at 4.5.2.) Standards that receive notice of proper Amending Motions (Certified Amending Motions) will be presented for action at the annual June NFPA Technical Meeting. At the meeting, the NFPA membership can consider and act on these Certified Amending Motions as well as Follow-up Amending Motions, that is, motions that become necessary as a result of a previous successful Amending Motion. (See 4.5.3.2 through 4.5.3.6 and Table 1, Columns 1-3 of *Regs* for a summary of the available Amending Motions and who may make them.) Any outstanding objection following action at an NFPA Technical Meeting (and any further Technical Committee consideration following successful Amending Motions, see *Regs* at 4.5.3.7 through 4.6.5) must be raised through an appeal to the Standards Council or it will be considered to be resolved.

VI. Step 3b: Documents Forwarded Directly to the Council. Where no NITMAM is received and certified in accordance with the *Technical Meeting Convention Rules*, the standard is forwarded directly to the Standards Council for action on issuance. Objections are deemed to be resolved for these documents. (See *Regs* at 4.5.2.5.)

VII. Step 4a: Council Appeals. Anyone can appeal to the Standards Council concerning procedural or substantive matters related to the development, content, or issuance of any document of the NFPA or on matters within the purview of the authority of the Council, as established by the *Bylaws* and as determined by the Board of Directors. Such appeals must be in written form and filed with the Secretary of the Standards Council (see *Regs* at Section 1.6). Time constraints for filing an appeal must be in accordance with 1.6.2 of the *Regs*. Objections are deemed to be resolved if not pursued at this level.

VIII. Step 4b: Document Issuance. The Standards Council is the issuer of all documents (see Article 8 of *Bylaws*). The Council acts on the issuance of a document presented for action at an NFPA Technical Meeting within 75 days from the date of the recommendation from the NFPA Technical Meeting, unless this period is extended by the Council (see *Regs* at 4.7.2). For documents forwarded directly to the Standards Council, the Council acts on the issuance of the document at its next scheduled meeting, or at such other meeting as the Council may determine (see *Regs* at 4.5.2.5 and 4.7.4).

IX. Petitions to the Board of Directors. The Standards Council has been delegated the responsibility for the administration of the codes and standards development process and the issuance of documents. However, where extraordinary circumstances requiring the intervention of the Board of Directors exist, the Board of Directors may take any action necessary to fulfill its obligations to preserve the integrity of the codes and standards development process and to protect the interests of the NFPA. The rules for petitioning the Board of Directors can be found in the *Regulations Governing Petitions to the Board of Directors from Decisions of the Standards Council* and in Section 1.7 of the *Regs*.

X. For More Information. The program for the NFPA Technical Meeting (as well as the NFPA website as information becomes available) should be consulted for the date on which each report scheduled for consideration at the meeting will be presented. To view the First Draft Report and Second Draft Report as well as information on NFPA rules and for up-to-date information on schedules and deadlines for processing NFPA documents, check the NFPA website (www.nfpa.org/docinfo) or contact NFPA Codes & Standards Administration at (617) 984-7246.

NFPA LINK[®]

Your window
to productivity

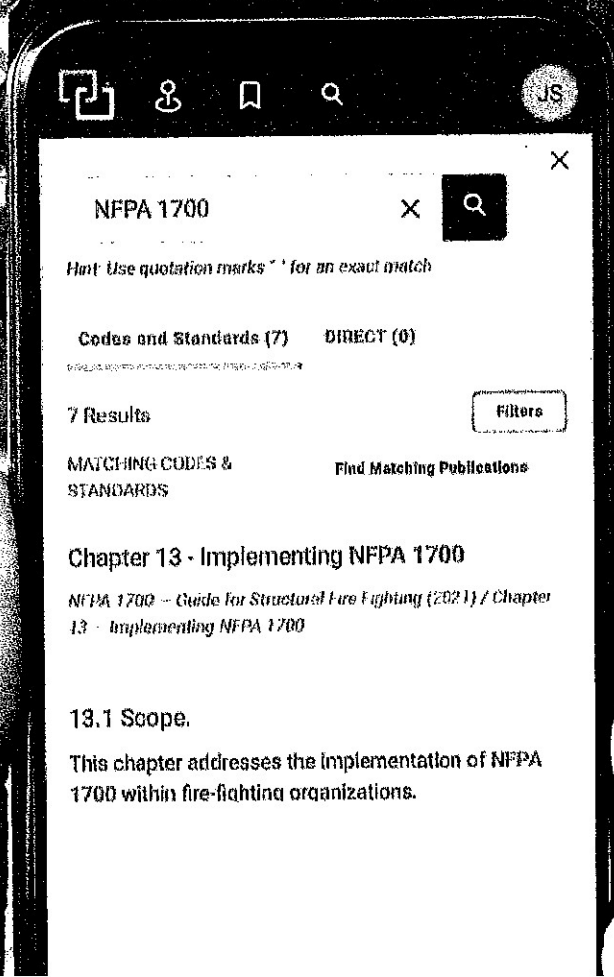

**SIGN UP NOW AT
NFPA.ORG/LINK**



