

**Article 9**  
**§ 190-69 Sign Regulations**

**A. General Provisions.**

- 1) The purpose of this section is to promote public safety and welfare by providing adequate standards to control the number, height, size, and location of signs and by providing criteria for the illumination and design of signs. The provisions and controls of this section have been formulated to protect against traffic distractions and hazards, to provide reasonable standards by which permitted uses within the various zones may relate their function to the public and to aid in preserving and enhancing the aesthetic and historical values of the community.
- 2) No sign (see definition) shall be established, constructed, structurally altered, or moved except in conformance with these Regulations.
- 3) In situations where the Planning and Zoning Commission approval is required to authorize a proposed land use, land use modification, or development, designs and locations for all proposed signs pertaining to the subject land use shall be submitted to the Commission as part of the permit approval process. Furthermore, any changes or alterations to signs approved by the Commission shall require site plan modification approval.
- 4) Where there is more than one (1) business tenant occupying a commercial site, a comprehensive sign plan showing consistent scale, materials, and style may be required by the Commission as part of a Special Permit application.

**B. Definitions.**

**Sign** – Any object, device, display, structure, or part thereof, or form of public announcement situated outdoors or indoors but intended to be visible outdoors intended to aid directly or indirectly in the sale of goods or services.

**Sign, Area** – The smallest rectangular area that encompasses all letters, designs, symbols, logos, or other sign features. It shall include any background material if such material is designed to be an integral part of the sign because of its texture, color, or arrangement. Supports that affix a sign to the ground or building shall not be included unless such supports are intentionally designed to be part of the sign. When attached to a wall, the area of the sign shall not include the wall itself unless the background is different from the balance of the wall and is designed as an integral part of or is obviously related to the sign. The area of any sign shall be determined by actual measurement.

Only one face of a double-faced sign shall be counted provided that both sign faces are equal in area and only one face can be seen at a time. If one face of a double-faced sign is larger than the gross area shall be the area of the largest face. For multiple-faced signs, the gross area shall be the combined area of all faces.

**Signs, Awning** – A sign consisting of letters, numbers or symbols applied to or integral with the fabric covering of an awning or awning-like structure.

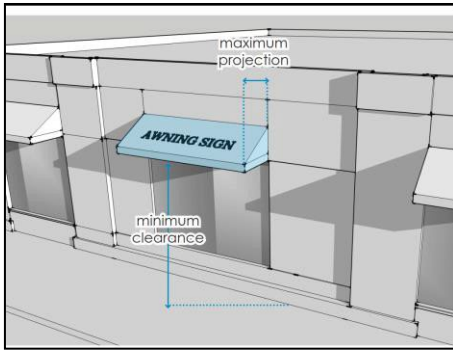

**Sign, Blade** – A sign (sometimes referred to as projecting bracket mounted sign) that is attached to, in whole or in part, of a building face or wall, and that projects in a perpendicular direction from such face or wall (or, in the case of a building corner, that projects in a direction that is approximately midway along the outside corner), and that contains two potential sign sides.

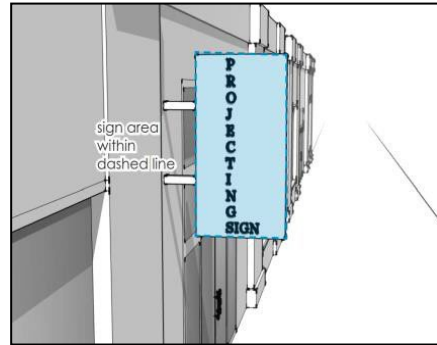
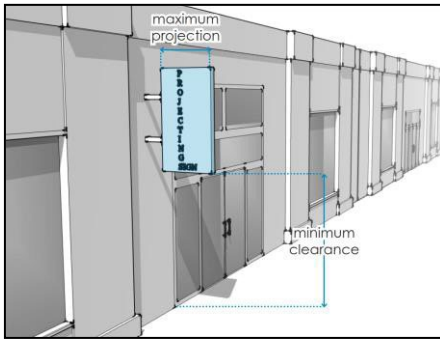

**Sign, Cabinet** – A sign structure comprised of a frame and face or faces. Though a cabinet sign may include electrical components or support structures, the cabinet sign refers only to the frame and face.

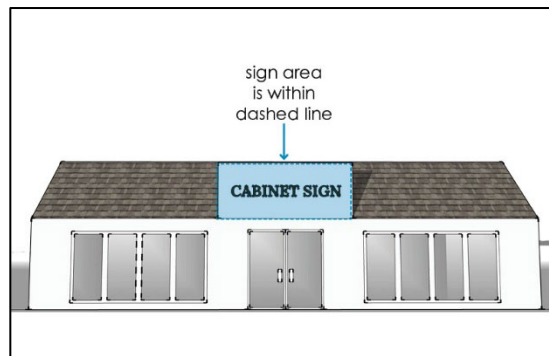
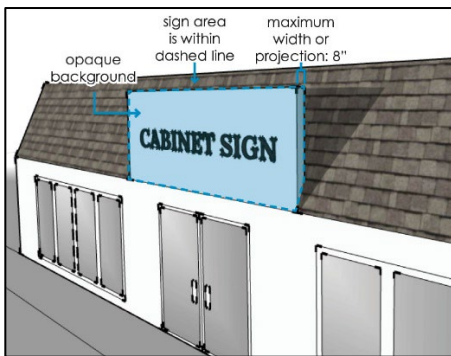

**Sign, Canopy** – A sign with individual alphanumeric characters and/or graphic elements that is mounted on top of a permanent canopy.

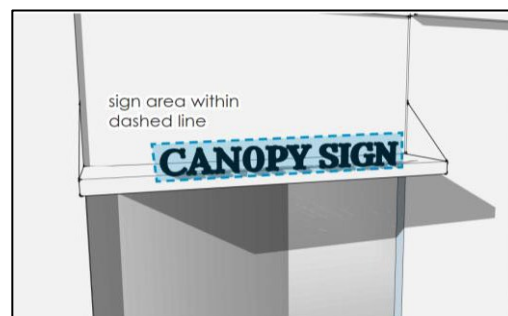
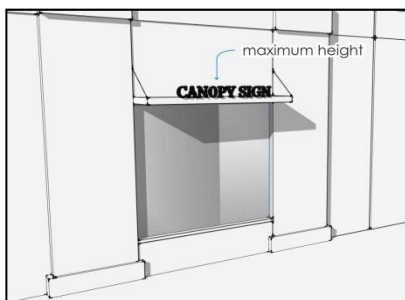

**Sign, Directional** – A sign indicating the direction of a route to the subject project, place, business, person, organization, etc.

**Sign, Freestanding** – Any non-portable permanent sign not affixed to a building.

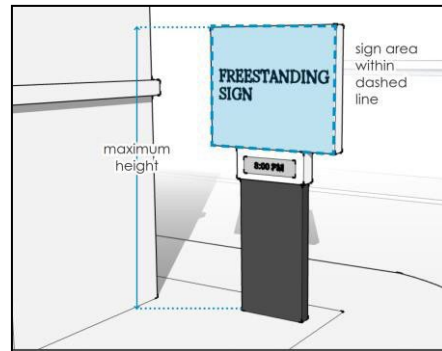
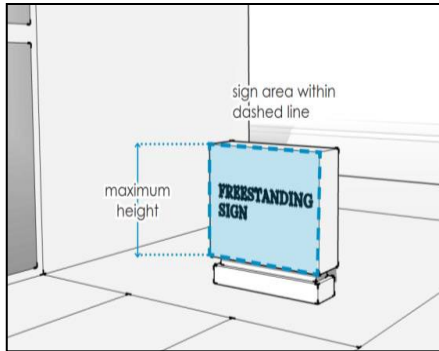

**Sign, Identity** – A sign depicting the individual name(s) or collective name of persons, organizations, or businesses operating on an individual site subject site. In addition to name information, an identity sign may include supplemental descriptive wording regarding the product/service offered at the site.

**Sign, Illuminated** – A sign lighted by or exposed to artificial lighting, either internally, externally, or indirectly as described below:

<b>Channel Lighting</b>	Direct Illumination included individual letters and symbols with a translucent face that are illuminated from within.
<b>Direct Illumination</b>	Illumination of a sign that emits any artificial light from a source of light within the interior of such a sign. A channel letter sign and an internally illuminated sign are examples of direct illumination.
<b>Halo Lighting</b>	Direct illumination including individual letters and symbols with an opaque face where lighting within illuminates the surface behind the letter or symbol.
<b>Indirect Illumination</b>	Illumination of a sign with an artificial light source that is external to the sign.

**Sign, Integrated Development**– A detached sign located on a parcel containing a development that was approved, designed, or designated as a business, professional, or industrial park.

**Sign, Menu Board** – A detached or wall-mounted sign Located on a property containing an approved drive-through food establishment

**Sign, Overhanging** – A sign extending from a building which is its sole support.

**Sign, Project** – A sign located on the premises for which an approved construction activity is taking place during the period of such construction activity.

**Sign, Projecting Marquee** – A projecting sign designed to have manually changeable copy and 2 to 3 sign faces.

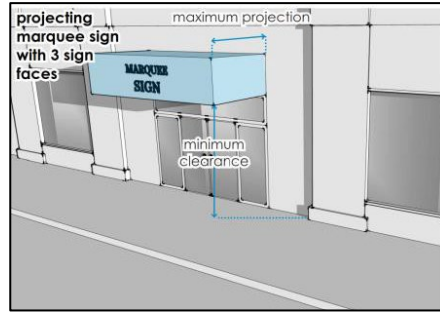
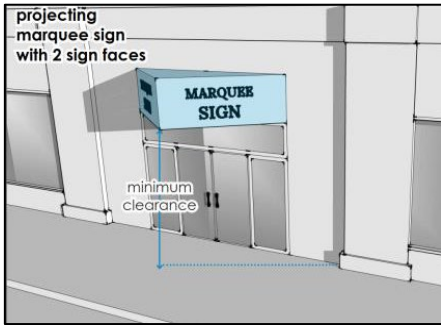

**Sign, Roof Mounted** – A sign mounted on any portion of a building's roof.

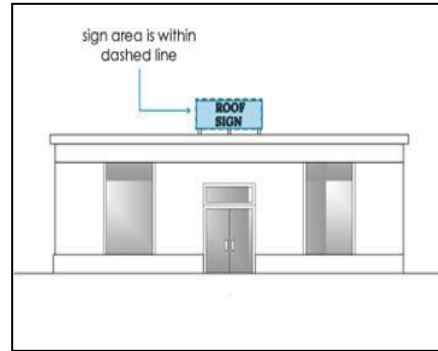

**Sign, Temporary** – A sign that has not been permitted, constructed, or located in a manner to provide for advertisement permanently.

**Sign, Unified Development**- A detached sign located on a parcel containing five (5) or more non-residential uses.

**Sign, Wall** – A sign on any surface or plane that may be affixed to the front, rear, or side wall of any building or any sign painted directly on any such wall.



**Sign, Window** – A sign posted, painted, placed, etched, or affixed in or on a window exposed for public view or hung inside the building facing the window for public view.

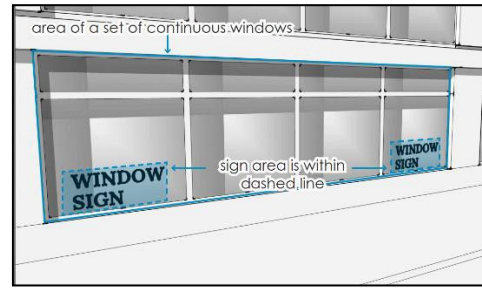
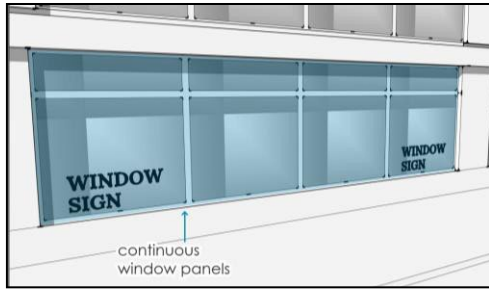

**Sign, Yard** – A sign located on any piece of property, affixed to or located on the ground, or any other structure or natural element that is visible from a public right of way or adjacent property.

**C. Prohibited signs.** The following signs shall be prohibited:

- 1) Flashing, rotating, moving, or blinking signs or optically projected slide signals that are changed periodically. This provision shall not apply to clocks or time/temperature signs that have been approved by the Planning & Zoning Commission.
- 2) Signs that are illuminated in a manner or with such intensity or brightness that they may cause glare, distraction, or nuisance to operators of vehicles, pedestrians, or neighboring property owners, or signs that are illuminated with a flashing, intermittent, or rotating source of light.
- 3) Signs including structural elements that may tend to endanger vehicular or pedestrian traffic on a street, driveway, or public way by obstructing or obscuring visibility or by causing confusion with traffic control signs or signals.
- 4) Signs including structural elements that obstruct any window, door, fire escape, stairway, or opening intended to provide light, air, ingress, or egress from any building or structure.
- 5) Banners, inflatables or flag-like devices, inflatable “dancer” signs, searchlights or similar devices.
- 6) Signs that are painted, bolted, or otherwise attached to a vehicle, trailer, or similar portable device that is parked or located on the subject lot in a manner designed to display and promote the viewing of the subject sign.
- 7) Roof-mounted signs.
- 8) Any sign erected, painted, or maintained upon fences, rocks, trees, or any natural feature.
- 9) Electronic message signs with changing text or graphics generated by electronic components.
- 10) Exposed neon signs unless such signs are permitted and mounted on the interior of first-floor storefront windows.
- 11) Any sign not specifically authorized within these Regulations.

## D. Sign Design and Construction Standards

- 1) Signs shall be constructed of weatherproof material, firmly supported and maintained in good condition, and repaired by the owner or lessee of the subject property.
- 2) All signs shall be compatible in scale, design, color, and construction with the architectural style of the building(s) and with the neighborhood within which they are located. The structural portions of signs (columns, crossbeams, braces, etc.) shall be proportional to the sign panel they are supporting.
- 3) All sign wording shall utilize lettering with a minimum height of three inches, except for wording for a site's common name, the sign wording for the name shall utilize lettering with a minimum height of seven inches, and minor accessory wording or symbols ("and", "+" or "&", etc.), which may have smaller-sized lettering.
- 4) Where more than one attached sign is located upon a building facade, the subject signs shall be compatible in scale, design, color, and construction with the architecture of the building and other signs on the site.
- 5) Lighting:
  - a) All lighting of signs shall be low-intensity, non-intermittent, and shielded so that the source of illumination is not visible from any street or any adjacent lot.
  - b) Internally illuminated cabinet signs shall be designed to incorporate opaque backgrounds with translucent lettering.
  - c) All sign lighting shall be designed to illuminate the sign face and, as appropriate, associated plantings, while not resulting in light spillover.
  - d) Externally mounted light fixtures shall be mounted on the top of the sign structure and aimed downward unless it can be demonstrated that alternative designs will not result in light spillover.
  - e) Signs shall only be illuminated during business hours. The average level of illumination on the vertical surface of the sign shall not exceed three (3) foot-candles.
- 6) Landscaping:

Freestanding signs shall meet the ground in an attractive manner. The use of appropriate plantings with year-round attractiveness, shall be required in conjunction with the approval of a new sign if necessary for compliance with this section.
- 7) Signs shall be designed to use simple fonts.
- 8) A combination of both upper- and lower-case lettering is easier to read than all upper case. Letter height must be greater to achieve the same level of legibility if all upper-case lettering is used.
- 9) Light colored copy on contrasting, darker background is recommended, whether illuminated or non-illuminated.
- 10) A well-defined edge or border to a sign is encouraged to increase visibility.
- 11) A cabinet sign shall not project more than 8 inches from the surface in which it is mounted and shall not include raised lettering.

- 12) Sign area. For determining the area of a sign, the following standards, in conjunction with the definition of sign, area, shall apply:
- a) For single or double-faced signs, the area shall be the square footage of the largest face.
  - b) For all other sign types and configurations, the area shall be the combined area of all faces.

**E. Total Allowed Signage Increase**

The Commission recognizes that through the adoption of these regulations, unique circumstances may exist which necessitate flexibility to ensure that unintended non-conformities are not created. As such, the Commission may grant approval (with or without a public hearing) for a single sign that exceeds the criteria for sign area established by this Section by not more than twenty-five percent (25%), provided the following criteria have been met:

- a) A color rendering of the proposed sign has been provided.
- b) A location map indicating the proposed location of the sign has been provided.
- c) The proposed sign location will not obstruct pedestrian or vehicular traffic or sight lines.
- d) The approval of such a request will not result in the creation of any new or expansion of any existing non-conformities.

**F. Temporary Signs**

Description	Max. Number	Max. Area	Permit	Property Use	Illumination
<b>Roadside Sign</b>					
Shall not be displayed for more than 60 days per calendar year. Signs shall be located on the same premise as the business and shall not obstruct visibility.	1 per parcel	4 sq. ft.	Not required	Non-Residential	None
<b>Sidewalk Sign</b>					
One sandwich-board-style sign displayed during business hours and placed no more than 10 feet from the primary entry door to the business. Placement of such sign shall not obstruct pedestrians or vehicular access. Separation distance between signs shall be 25'.	1 per business	4 sq. ft.	Not required	Non-Residential	None
<b>Seasonal Sign</b>					
A non-permanent, portable, sandwich-board style sign or lawn-style sign may be displayed during operation of the use but may not be displayed year-round.	None	2 sq. ft.	Not required	Seasonal or Temporary	None
<b>Project Sign/Sale and Rental Signs</b>					
Located on a property actively offered for sale or lease or, during the time when such property is actively under construction, repair, or improvement to be removed within thirty (30) days following project completion. Size limitation does not apply for signs mandated by the State or Federal Government.	1	16 sq. ft.	Not required	Residential	None
	1	32 sq. ft.		Non-Residential	

<b>Yard Sign</b>					
Affixed to, or located on the ground, or any other structure or natural element, visible from a public right of way or adjacent property, displayed for a period not to exceed sixty (60) days	None	4 sq. ft. each	Not required	Any	None
<b>Development Sign</b>					
Located on a property with an active zoning approval related to the development and construction of a commercial building(s) or multiple residential dwellings, for a period not to exceed three (3) years. An additional extension of up to three (3) years may be granted by the Commission.	1 per street frontage	32 sq. ft.	Zoning Permit	Any	None

**G. Permanent Signs: Permitted in Non-Residential Districts**

**1. Attached Signs**

Description	Max. Number	Max. Area	Permit	Illumination
<b>Primary Attached Signs</b>				
A wall sign mounted parallel to building façade, extending not more than 8 inches from wall; <u>or</u> ,	1 per business	1 sq. ft. per lineal ft. of building frontage	Zoning Permit	Direct or Indirect
In lieu of a wall sign, a sign projecting perpendicular or oblique to the building or extending more than 16 inches from the wall.				
An additional wall sign of equal size and design to the primary sign; or in the case of buildings with multiple frontages or multiple entrances, an additional principal entrance sign may be permitted	1 per public entrance	1 sq. ft. per lineal ft. of building frontage		
<b>Canopy Sign</b>				
In lieu of an additional wall sign, painted or affixed to a canopy.	1	0.5 sq. ft. per linear ft. of building frontage	Zoning Permit	None
<b>Window Signs</b>				
Window sign	N/A	40% of window area of façade containing the primary public entrance	None	None



## 2. Detached Signs

Description	Max. Number	Max. Area	Permit	Illumination
<b>Freestanding</b>				
Freestanding sign	1 per parcel	32 sq. ft.	Zoning Permit	Direct or Indirect
For parcels with more than one street frontage one additional freestanding sign may be authorized	1 per street frontage	12 sq. ft.	Commission	Direct or Indirect
<b>Menu Board</b>				
Located on a property containing an approved drive-through food establishment	1	25 sq. ft.	Commission	Direct
<b>Identity Sign</b>				
Located on a property containing a commercial development with 2-5 businesses on a single parcel	1	32sq. ft.	Commission	As approved by Commission
<b>Integrated Development Sign</b>				
For developments that have been approved, designed, or designated as a business, professional park	1 per major entrance	32 sq. ft.	Commission	None
<b>Interior Directional Sign</b>				
Shall be set back a minimum of 100 feet from a public street or oriented so that it is not directed toward traffic on a public street.	As approved by Staff	3 sq. ft.	Staff	None
<b>Unified Development Sign</b>				
For developments with five (5) or more businesses on a single parcel	1 per major entrance	32 sq. ft.	Commission	As approved by Commission

## H. Permanent Signs: Permitted in Residential Districts

Description	Max. Number	Max. Area	Permit	Illumination
<b>Announcement Sign</b>				
Located within 10 feet of the building and on the premises for which an approved Home Occupation permit has been issued.	1	4 sq. ft.	None	Indirect
<b>Integrated Development Sign</b>				
On properties with a valid subdivision, multi-family development, or mobile home park project approval.	1	32 sq. ft.	Commission	Indirect
<b>Directional Device</b>				
On-premises traffic control structure necessary for direction, convenience of the public and control of traffic and parking and in accordance with the Manual on Uniform Traffic Control Devices, as amended.	N/A	3 sq. ft.	None	None

**I. Signs Permitted in the Storrs Center Special Design District**

[See the Storrs Center Special Design District—§190-48](#)

**J. Sign Enforcement and Removal**

- 1) The issuance of Zoning Permits and any necessary enforcement action due to violations of the provisions of these sign regulations shall be administered in accordance with the provisions of §190-88.
- 2) Provided all applicable provisions of these regulations are met, including color and design requirements for buildings and developments with multiple signs, and provided any previous approval conditions are met, a separate Zoning Permit shall not be required for the repainting or alteration of the copy on an approved sign which is specifically designed for the use of replacement copy. The use of a new sign or any proposed structural changes to a sign requires the issuance of a new Zoning Permit.
- 3) Signs that become unsafe, unsightly, physically damaged, or otherwise in violation of these regulations shall, upon notice from the Zoning Agent, be repaired or replaced by the owner or lessee of the property on which the sign is located within 30 days of said notice.
- 4) To provide for and encourage the removal of any sign which is not in active use or has remained in place for the purposes of preserving a lawfully existing non-conformity, the Zoning Agent in conjunction with the property owner may document the details of such sign along with the owner's intent to re-establish such signage in the future.

**K. Sign Maintenance**

- 1) Signs shall be maintained in good condition and repair.
- 2) A sign which may be unsafe is in disrepair, or creating a hazard shall, upon notice from the Zoning Agent, be repaired or removed by the owner or lessee of the property on which such signs stand within 30 days of said notice.