

**CITY OF SEA ISLE CITY
NEW JERSEY**

ORDINANCE NO. 1690 (2022)

**AN ORDINANCE TO AMEND THE REVISED GENERAL
ORDINANCES OF THE CITY OF SEA ISLE CITY, CHAPTER 26-27 ENTITLED
“ENCROACHMENTS” TO UPDATE ENCROACHMENT SETBACKS**

WHEREAS, the Council of the City of Sea Isle City continues to review and update its ordinances; and

WHEREAS, the Council of the City of Sea Isle City shall update its side yard setback for “bump outs”; and

NOW, THEREFORE, BE IT ORDAINED by the Council of the City of Sea Isle City, County of Cape May and State of New Jersey as follows:

SECTION I. Chapter 26 Section 27.6 of the Revised General Ordinances of the City of Sea Isle City, entitled “Encroachments” is hereby amended to delete the following section in its entirety and replace same as follows:

DELETED SECTION:

26-27.6 Encroachments

Architectural Enhancements. Setback encroachment allowance for certain architectural features.

1. In all yards that are seven feet (7') or greater in width, projections for decorative, ornamental or canopy overhangs over exterior doors or windows shall be permitted to extend up to two feet (2') into the yard setback over the exterior doors or windows. All overhangs in all yards shall be a minimum of five feet (5') from the property line.
2. In side yards that are six feet six inches (6'6") or greater in width, projections shall be permitted up to eighteen inches (18") in depth and eight feet (8') in length. Any projections must be separated by seven feet (7'). All projections into side yards shall be a minimum of five (5') feet from the property line. All measurements herein shall be as measured on the exterior of the structure.

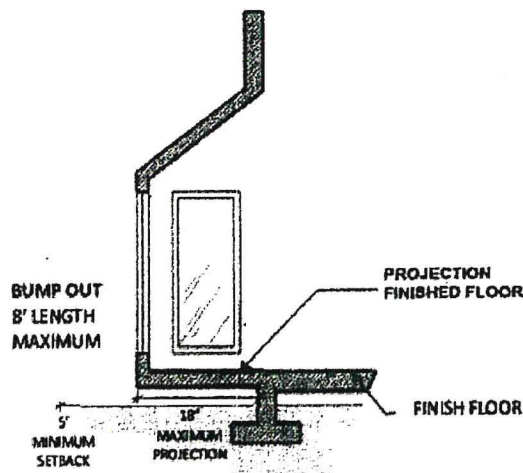

3. In corner lot yards, with two (2) front yards, where the yards are six feet six inches (6'6") or greater in width, projections shall be permitted up to eighteen inches (18") in depth and eight feet (8') in length. Projections shall be limited to two (2) yards where these projections are encroaching into the permitted setback. Any projections must be separated by seven feet (7'). All measurements herein shall be as measured on the exterior of the structure.

REPLACEMENT SECTION:

26-27.6 Encroachments

Architectural Enhancements. Setback encroachment allowance for certain architectural features.

1. In all yards that are seven feet (7') or greater in width, projections for decorative, ornamental or canopy overhangs over exterior doors or windows shall be permitted to extend up to two feet (2') into the yard setback over the exterior doors or windows. All overhangs in all yards shall be greater than five feet (5') from the property line. All measurements herein shall be as measured on the exterior of the structure.
2. Projections shall be permitted in the side yard when said projections are a minimum of 12" in depth, do not exceed 18" in depth, do not exceed 8 feet in length, are separated by 7 feet and are greater than 5 feet from the property line. All measurements herein shall be as measured on the exterior of the structure.

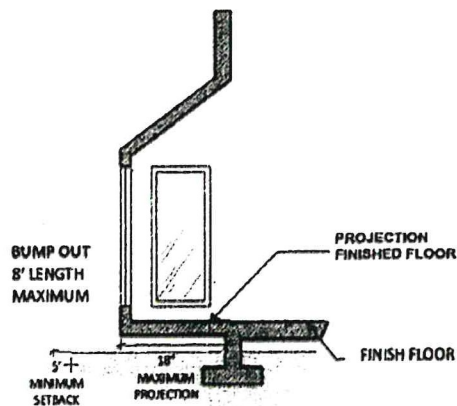

3. In corner lot yards, with 2 front yards, projections shall be permitted in 2 yards only. If placed within the front or rear yard such projection shall encroach in said yard no more than 18" in depth, be a minimum of 12" in depth, not exceed 8 feet in length, and be separated by 7 feet. If placed in the side yard such projections shall comply with section 2 above. All measurements herein shall be as measured on the exterior of the structure.

SECTION II. Severability. If for any reason any section of this Ordinance shall be declared illegal by any Court of competent jurisdiction, the remaining section of the Ordinance shall remain in full force and effect, notwithstanding.

SECTION III. Repealer. Any Ordinance or provision thereof inconsistent with this Ordinance is hereby repealed to the extent of such inconsistency.

SECTION IV. Publication. This Ordinance shall take effect immediately upon the adoption and publication in accordance with the law.

Mary Tighe, Council President

Mayor Leonard C. Desiderio

I HEREBY CERTIFY THAT the foregoing ordinance was duly passed by the City Council of the City of Sea Isle City, New Jersey on first reading at the regular meeting of said Council held on the 27th day of September, 2022 and was taken up for second reading, public hearing and final passage at the regular meeting of said Council held on the 22nd day of November, 2022, in City Hall, 3rd Floor Council Chambers, 233 JFK Blvd., Sea Isle City, New Jersey at 10:00 a.m.

Shannon D. Romano, Municipal Clerk