

VANDERGRIFT BOROUGH
WESTMORELAND COUNTY, PENNSYLVANIA
STORMWATER MANAGEMENT ORDINANCE

ORDINANCE NO. 1 OF 2021

Adopted at a Public Meeting Held On January 4, 2021

VANDERGRIFT BOROUGH
WESTMORELAND COUNTY, PENNSYLVANIA
Stormwater Management Ordinance

ARTICLE I General Provisions

- §101. *Short Title.*
- §102. *Findings.*
- §103. *Purpose.*
- §104. *Statutory Authority*
- §105. *Applicability.*
- §106. *Repealer*
- §107. *Severability*
- §108. *Compatibility with Other Requirements.*
- §109. *Erroneous Permit*
- §110. *Prohibitions*
- §111. *Liability Disclaimer.*

ARTICLE II Definitions.

- §201. *Interpretations and word usage*
- §202. *Definitions of terms.*

ARTICLE III Stormwater Management Performance Standards.

- §301. *Stormwater Management Performance Districts.*
- §302. *General Requirements*
- §303. *Exemption from performance standards.*
- §304. *No-Harm Option*
- §305. *Waivers / Modifications / Demonstrated Equivalency*
- §306. *Small Project*
- §307. *General Standards*
- §308. *Watershed Standards*
- §309. *Design Criteria for Stormwater Management Facilities and BMPs*
- §310. *Erosion and Sedimentation Controls.*
- §311. *Water Obstructions and Encroachments*

ARTICLE IV Stormwater Management Plan Requirements.

- §401. *General Requirements.*
- §402. *Stormwater Management Plan Contents.*
- §403. *Other Permits/Approvals.*
- §404. *Operation and Maintenance Program*
- §405. *Financial Guarantees*

ARTICLE V Stormwater Management Plan Submission and Review Procedures.

- §501. *Preapplication Phase.*
- §502. *Stormwater Management Plan Submission and Review*
- §503. *Status of Stormwater Management Plan after Approval.*
- §504. *Modification of Stormwater Management Plan*
- §505. *Inspection of Stormwater Management Facilities and BMPs*
- §506. *Record Drawings, Completion Certificate, and Final Inspection*

ARTICLE VI Operation and Maintenance of Stormwater Facilities and BMPs

- §601. *Operation and Maintenance Responsibilities.*
- §602. *Stormwater Facility and BMP Operations and Maintenance Plan Requirements*
- §603. *Operations and Maintenance Agreement for Privately Owned Stormwater Facilities and BMPs*
- §604. *Vandergrift Borough Stormwater and BMP Operation and Maintenance Fund.*

ARTICLE VII Fees, Financial Guarantees and Dedication of Public Improvements.

- §701. *Guarantee of Completion*
- §702. *Release of Completion Guarantee.*
- §703. *Default of Completion Guarantee*
- §704. *Dedication of Public Improvements.*
- §705. *Maintenance Guarantee.*
- §706. *Fees and Expenses*

ARTICLE VIII Enforcement Procedures and Remedies.

- §801. *Right of Entry*
- §802. *Enforcement Generally*
- §803. *Suspension and Revocation*
- §804. *Preventative Remedies*
- §805. *Violations and Penalties.*
- §806. *Additional Remedies*
- §807. *Appeals*

REFERENCES

APPENDICES

Appendix A Vandergrift Borough Stormwater Management Performance Districts

Appendix B Samples: Landowner Letter of Acknowledgement (for Small Projects only)
Operation and Maintenance Agreement (for SWM Site Plans)

Appendix C Small Project Stormwater Management Site Plan and Worksheet

Appendix D Stormwater Management Plan Sample Checklist

Appendix E Fee Schedule

ORDINANCE NO. 1 OF 2021

ORDINANCE OF THE BOROUGH OF VANDERGRIFT, WESTMORELAND COUNTY, PENNSYLVANIA REGARDING STORM WATER MANAGEMENT

WHEREAS, pursuant to the Pennsylvania Stormwater Management Act, Act 167 of 1978, as amended, the County of Westmoreland, Pennsylvania created and adopted an Integrated Water Resources Plan and a model Stormwater Management Ordinance; and

WHEREAS, pursuant to Section 11(b) of Act 167, 32 P.S. §680.11(b), the Borough of Vandergrift is required to adopt local regulations consistent with the Integrated Water Resources Plan; and

WHEREAS, Council of the Borough of Vandergrift desires to enact the following stormwater management regulations.

NOW, THEREFORE, BE IT ORDAINED by the Council of the Borough of Vandergrift in a duly advertised meeting assembled and by the authority of the same:

SECTION 1. The Borough of Vandergrift amends and creates a new Vandergrift Code Chapter _____, entitled “Stormwater Management” by adding the following articles and appendices:

ARTICLE I General Provisions

§101. Short Title.

This Ordinance shall be known and may be cited as the “Vandergrift Borough Stormwater Management Ordinance.”

§102. Findings.

The Council of the Borough of Vandergrift finds that:

- A. Stormwater runoff from lands modified by human activities threatens public health and safety by causing decreased infiltration of rainwater and increased runoff flows and velocities, which overtax the carrying capacity of existing streams and storm sewers, causes property damage and risk to public safety, and greatly increases the cost to the public to manage stormwater.
- B. Inadequate planning and management of accelerated stormwater runoff resulting from land development and redevelopment throughout a watershed can also harm surface water resources by changing the natural hydrologic patterns, accelerating stream flows (which increase scour and erosion of stream-beds and stream-banks thereby elevating sedimentation), destroying aquatic habitat and elevating aquatic pollutant concentrations and loadings such as sediments, nutrients, heavy metals and pathogens. Groundwater resources are also impacted through loss of recharge.

- C. Vandergrift Borough is located entirely within the Kiskiminetas River Watershed and as such will endeavor to cooperate with other municipalities located in the watershed to address issues of stormwater management, water quality, pollution and flooding.
- D. Non-stormwater discharges to municipal separate storm sewer systems can contribute to pollution of waters of the Commonwealth in the Borough of Vandergrift.
- E. Stormwater can be an important water resource by providing groundwater recharge for water supplies and base flow of streams, which also protects and maintains surface water quality.
- F. Public education on the control of pollution of stormwater is an essential component in successfully managing stormwater.
- G. A comprehensive program of stormwater management, including reasonable regulation of land development and redevelopment causing loss of natural infiltration, is fundamental to the public health, safety, welfare, and the protection of the people of the Borough of Vandergrift and all the people of the Commonwealth, their resources, and the environment.
- H. The use of open space conservation, green infrastructure, low impact development (LID), and riparian buffers are intended to address the root cause of water quality impairment by using systems and practices which use or mimic natural processes to: 1) infiltrate and recharge, 2) evapotranspire, and/or 3) harvest and use precipitation near where it falls to earth. Green infrastructure practices, LID, and riparian buffers contribute to the restoration or maintenance of pre-development hydrology.
- I. Stormwater structures are considered vital infrastructure and can pose a significant hazard. Outlets and waterways which carry stormwater shall be maintained free of obstructions to allow for non-restricted flow of stormwater to avoid impoundment of water.
- J. Occupancy and modification of floodplains shall be avoided wherever there is a practicable alternative to reduce long and short-term adverse impacts in order to reduce the risk of flood loss, minimize the impact of floods on human safety, health and welfare, and to restore and preserve the natural and beneficial values served by floodplains.
- K. Federal and State regulations require certain municipalities to implement a program of stormwater controls. These municipalities are required to obtain a permit for stormwater discharges from their municipal separate storm sewer systems (MS4) under the National Pollutant Discharge Elimination System (NPDES). Vandergrift Borough is subject to MS4 requirements.
- L. The Westmoreland Conservation District (WCD) is a recognized regulatory agency with authority in the county and this municipality to regulate erosion and sediment controls and stormwater management related to land development activities. Because WCD's

authority crosses municipal boundaries they are enabled to oversee environmental issues for the general benefit of all county residents.

- M. The Westmoreland County Integrated Water Resources Plan (current edition) addresses all water resources and provides a decision-making tool for development and redevelopment with respect to those resources including stormwater and its management. Refer to www.paiwrp.com and www.westmorelandstormwater.org
- N. This Ordinance is based on the PADEP 2022 MODEL STORMWATER MANAGEMENT ORDINANCE (5/2016), and was created as part of the Westmoreland County Integrated Water Resources Plan 2020. Its creation was guided by the Watershed Planning Advisory Committee, the Westmoreland Conservation District, the Westmoreland County Department of Planning and Development; approved by the PA DEP February 4, 2020; and formally adopted by the Westmoreland County Commissioners by Resolution June 4, 2020.
- O. The Pennsylvania Storm Water Management Act (Act 167 of 1978) requires municipalities to “adopt or amend, and shall implement such ordinances and regulations, including zoning, subdivision and development, building code, and erosion and sedimentation ordinances, as are necessary to regulate development within the Borough in a manner consistent with the applicable watershed stormwater plan and the provisions of this act”.
- P. Federal regulations at 40 CFR § 122.34 require the use of ordinances by small MS4s to address 1) the prohibition of unauthorized non-stormwater discharges (MCM #3), 2) erosion and sediment controls for construction activities involving earth disturbances of one acre or more (or disturbances less than one acre if the construction activity is part of a larger common plan of development or sale that would disturb one acre or more) (MCM #4), and 3) post-construction stormwater management for new development and redevelopment projects (MCM #5). DEP expects that MS4 municipalities will update existing ordinances to comply with the requirements of the MS4 program or, at a minimum, enact the DEP 2022 model ordinance by September 30, 2022.
- Q. DEP is directed under Act 167 to develop a model stormwater ordinance. DEP’s intention in publishing the 2022 Model Stormwater Management Ordinance is that its use will satisfy both Act 167 requirements, and MS4 regulatory requirements.

§103. Purpose.

The purpose of this Ordinance is to promote health, safety, and welfare within the Borough of Vandergrift and its watersheds by minimizing the harms and maximizing the benefits described in this Section of this Ordinance, through provisions designed to:

- A. Manage stormwater runoff impacts at their source by regulating activities that cause the problems, reducing runoff volumes and mimicking natural hydrology.
- B. Maintain existing flows and quality of streams and watercourses.

- C. Prevent scour and erosion of streambanks and streambeds.
- D. Utilize and preserve the existing natural drainage systems as much as possible.
- E. Restore and preserve the natural and beneficial values served by streamside and waterbody floodplains.
- F. Focus on infiltration of stormwater, to maintain groundwater recharge, to prevent degradation of surface and groundwater quality and to otherwise protect water resources.
- G. Promote stormwater runoff prevention and emphasize infiltration and evapotranspiration through the protection and conservation of natural resource systems and the use of non-structural BMPs and other creative methods of improving water quality and managing stormwater runoff.
- H. Promote the use of green infrastructure in development and redevelopment where it can also improve stormwater management within the broader watershed in which the project is located.
- I. Meet legal water quality requirements under state law, including regulations at 25 Pa.Code, Chapter 93.4a, to protect and maintain “existing uses” and maintain the level of water quality to support those uses in all streams, and to protect and maintain water quality in “special protection” streams.
- J. Provide review procedures and performance standards for stormwater planning and management.
- K. Provide for proper operations and maintenance of all permanent stormwater management BMPs that are implemented in the Borough of Vandergrift.
- L. Provide a mechanism to identify controls necessary to meet the NPDES and MS4 permit requirements where applicable, and to encourage infrastructure improvements that lead to separation of storm sewer systems from sanitary sewer systems.
- M. Assist in detecting and eliminating illicit stormwater discharges into Vandergrift Borough's separate storm sewer system.

§104. *Statutory Authority*

- A. The Borough of Vandergrift is empowered to regulate land use activities that affect stormwater runoff by the authority of the Stormwater Management Act of October 4, 1978, P.L. 864 (Act 167), 32 P.S. Section 680.1, et seq., as amended and the Borough Code, 8 Pa.C.S.A. §101, et seq., as amended.

§105. *Applicability.*

- A. All regulated activities as defined by this ordinance are subject to regulation by this Ordinance.
- B. This Ordinance applies to all land development and regulated earth disturbance activities within the Borough of Vandergrift, and all stormwater runoff entering into the Borough's separate storm sewer system from lands within the boundaries of the Borough.
- C. Earth disturbance activities and associated stormwater management controls are also regulated under existing State law and implementing regulations. This Ordinance shall operate in coordination with those parallel requirements; the requirements of this Ordinance shall be no less restrictive in meeting the purposes of this Ordinance than State law.
- D. The Borough shall have the discretion to require compliance with this Ordinance where existing conditions or previous development has created ongoing adverse environmental impacts due to a lack of, or improperly implemented stormwater management which the Borough determines to have a substantial risk to life, health, safety, property or the environment.

§106. *Repealer*

Any other ordinance provision(s) or regulation of the Borough inconsistent with any of the provisions of this Ordinance is hereby repealed to the extent of the inconsistency only.

§107. *Severability*

If any word, phrase, section, sentence, clause or part of this Ordinance is for any reason found to be unconstitutional, illegal or invalid, such unconstitutionality, invalidity or illegality by a court of competent jurisdiction, shall not affect or impair any of the remaining words, phrases, sections, sentences, clauses or parts of this Ordinance. It is hereby declared to be the intent of the Council of the Borough of Vandergrift that this Ordinance would have been adopted had such unconstitutional, illegal or invalid word, phrase, section, sentence, clause or part thereof not been included herein.

§108. *Compatibility with Other Requirements.*

- A. Approvals issued and actions taken under this Ordinance do not relieve the applicant of the responsibility to secure required permits or approvals for activities regulated by any other code, law, regulation or ordinance. To the extent that this Ordinance imposes more rigorous or stringent requirements for stormwater management, the specific requirements contained in this Ordinance shall be followed.

- B. Conflicting provisions in other Borough ordinances or regulations shall be construed to retain the requirements of this Ordinance addressing state water quality requirements.

§109. Erroneous Permit

Any permit or authorization issued or approved based on false, misleading or erroneous information provided by an applicant is void without the necessity of any proceedings for revocation. Any work undertaken or use established pursuant to such permit or other authorization is unlawful. No action may be taken by a board, agency or employee of the Borough purporting to validate such a violation.

§110. Prohibitions

Prohibitions shall be consistent with PAG-13 NPDES General Permit for stormwater discharges from MS4 communities and as listed here.

A. Prohibited discharges

1. No person in the Borough of Vandergrift shall introduce, permit or allow, or cause to introduce, permit or allow, stormwater discharges into the Borough separate storm sewer system which are not composed entirely of stormwater, except as permitted by this Ordinance, or
 - a. as provided in paragraph 2. below, or
 - b. discharges as authorized under a State or Federal permit.
2. Permissible discharges, based on a finding by the Borough that the discharge(s) do not significantly contribute to pollution to surface waters of the Commonwealth, are recommended to be discharged safely to a vegetated area or infiltration BMP, but can also be discharged to a storm sewer system, include but are not limited to:
 - a. Discharges from firefighting activities.
 - b. Potable water sources including dechlorinated water line and fire hydrant flushing.
 - c. Non-contaminated irrigation drainage from agricultural practices.
 - d. Routine external building washdown (which does not use detergents or other compounds).
 - e. Non-contaminated Air conditioning condensate.
 - f. Water from individual residential car, boat or other residential vehicle washing that does not use detergents or other compounds.

- g. Springs.
 - h. Non-contaminated Water from basement or crawl space sump pumps.
 - i. Non-contaminated water from foundation or from footing drains.
 - j. Flows from riparian habitats and wetlands.
 - k. Lawn watering.
 - l. Pavement wash-water where spills or leaks of toxic or hazardous materials have not occurred (unless all spill material has been removed) and where detergents are not used.
 - m. Splash pad (recreational spray patio with no standing water) discharges.
 - n. Non-contaminated groundwater.
 - o. Dechlorinated swimming pool water.
3. In the event that the Borough determines that any of the discharges identified in paragraph 2. above significantly contributes to pollution of waters of the Commonwealth, or is so notified by DEP, the Borough will notify the landowner and/or the responsible person to cease the discharge.
 4. Upon notice provided by the Borough under paragraph 3. above, the discharger will have a period of time as determined by the Borough, to cease the discharge consistent with the degree of pollution caused by the discharge.
 5. Nothing in this Section shall affect, limit or alleviate a discharger's responsibilities under State or Federal law.

B. Prohibited connections.

The following sources, activities or connections are prohibited, except as provided in subsection A. 1. and 2. above:

1. Any drain or conveyance, whether on the surface or subsurface, which allows any non-storm water discharge including but not limited to, sewage, process wastewater and wash water, to enter the separate storm sewer system, and any connections to the storm drain system from indoor drains and sinks.

2. Any drain or conveyance connected from a commercial, industrial or other non-residential land use to the separate storm sewer system which has not been documented in plans, maps, or equivalent records, and approved by the Borough of Vandergrift.
3. Drains carrying stormwater or groundwater shall not be connected to or discharge to any public or private sanitary sewer system or facility.

C. Prohibited activities:

1. A landowner may not alter the natural flow of surface water on his property by concentrating it in an artificial channel and discharging it upon lower land of his neighbor even though no more water is thereby collected than would naturally have flowed upon the neighbor's land in a diffused (shallow broad path or sheet flow) condition.
2. A landowner may not alter any BMP's, facilities or structures that were installed under this ordinance or the Borough's preceding Stormwater Management Regulations without written approval of the Municipality.

D. Roof Drains and Sump Pumps

1. Roof drains and sump pumps shall discharge to infiltration or vegetative BMP's wherever feasible.

§111. *Liability Disclaimer.*

- A. Neither the granting of any approval under the stormwater management provisions of this Ordinance, nor the compliance with the provisions of this Ordinance, or with any condition imposed by any public body of the Borough or by a Borough official, employee or consultant hereunder, shall relieve any person from any responsibility for damage to person or property resulting therefrom, or as otherwise imposed by law, nor impose any liability upon the Borough for damages to persons or property.
- B. The granting of a permit which includes any stormwater management does not constitute a representation, guarantee or warranty of any kind by the Borough or the Westmoreland Conservation District (WCD), or by an official or employee thereof, of the practicability or safety of any structure, use or other plan proposed and shall create no liability upon or cause of action against such public body, official or employee for any damage that may result pursuant thereto.

ARTICLE II Definitions.

§201. Interpretations and word usage:

For the purposes of this Ordinance, the terms and words used herein shall be interpreted as follows:

- A. Words used in the present tense include the future tense; the singular number includes the plural, and the plural number includes the singular; words of masculine gender include feminine gender; and words of feminine gender include masculine gender.
- B. The word “includes” or “including” shall not limit the term to the specific example but is intended to extend its meaning to all other instances of like kind and character.
- C. The words “shall” and “must” are mandatory; the words “may” and “should” are permissive.

§202. Definition of terms:

Act 167 – the Stormwater Management Act, Act of October 4, 1978, P. L. 864, No. 167, as amended by the Act of May 24, 1984, No. 63, 32 P.S. §§680.1 *et seq.* The Borough is empowered to regulate land use activities that affect runoff and surface and groundwater quality and quantity by the authority of the Act, the “Storm Water Management Act.”

Accelerated Erosion – the removal of the surface of the land through the combined action of human activities and the natural processes at a rate greater than would occur because of the natural process alone.

Agricultural Activity – Activities associated with agriculture such as agricultural cultivation, agricultural operation, and animal heavy use areas. This includes the work of producing crops and raising livestock including tillage, land clearing, plowing, disking, harrowing, planting, harvesting crops, or pasturing and raising of livestock and installation of Conservation Practices. Except for high tunnels that are exempt pursuant to the provisions of Act 15 of 2018, construction of new buildings or impervious areas is not considered an agricultural activity.

Applicant – a landowner, developer or other person who has filed an application for development or for approval to engage in any regulated earth disturbance activity at a project site in the Borough of Vandergrift.

Animal Concentration (heavy use) Areas – A barnyard, feedlot, loafing area, exercise lots, or other similar animal confinement areas that will not maintain a growing crop, or where deposited manure nitrogen is in excess of crop needs, but excluding areas managed as pastures or other cropland, and pasture access ways, if they do not cause direct flow of nutrients to surface water or groundwater.

BMP (Best Management Practice) – activities, facilities, designs, measures or procedures used to manage stormwater impacts from regulated development activities, to meet State water quality requirements, to promote groundwater recharge and to otherwise meet the purposes of this Ordinance. BMPs include, but are not limited to, infiltration, filter strips, low impact design, bioretention, wet ponds, permeable paving, grass lined swales, forested buffers, sand filters and detention basins.

Channel – a perceptible natural or artificial waterway which periodically or continuously contains moving water or which forms a connecting link between two bodies of water. It has a definite bed and banks which confine the water.

Chapter 102 – Title 25 Pa Code Chapter 102 Erosion and Sedimentation Control.

Chapter 105 – Title 25 Pa Code Chapter 105 Dam Safety and Waterway Management.

Combined Sewer System – A sewer system designed to serve as both sanitary sewer and storm sewer.

CSO, Combined Sewer Overflow – An intermittent flow or other untreated discharge from a municipal combined sewer system (including domestic, industrial and commercial wastewater and stormwater) which results from a flow in excess of the dry weather carrying capacity of the system.

Conservation District – the Westmoreland Conservation District (WCD), as defined in Section 3(c) of the Conservation District Law (3 P. S. § 851(c)) that has the authority under a delegation agreement executed with DEP to administer and enforce all or a portion of the regulations promulgated under 25 Pa. Code 102.

Conservation Plan – A plan written by an NRCS or SCS certified planner that identifies Conservation Practices and includes site specific BMPs for agricultural plowing or tilling activities and Animal Concentration Areas.

Conservation Practices – Practices installed on agricultural lands to improve farmland, soil and/or water quality which have been identified in a current Conservation Plan.

Conveyance –

- (a) Any structure that carries a flow.
- (b) The ability of a pipe, culvert, swale or similar facility to carry the peak flow from the design storm.

Culvert – a closed conduit for the free passage of surface drainage under a highway, railroad, canal or other embankment.

DEP – the Pennsylvania Department of Environmental Protection.

Demonstrated Equivalency – A stormwater management project on an alternative site(s) within the same watershed as the proposed development that will provide equal or better achievement

of the purpose of the Ordinance and will not substantially or permanently impair the appropriate use or development of adjacent property. Examples include streambank stabilization, creation or enhancement of riparian buffers, removal of existing impervious surfaces and establishment of 'green' easements, installation of stormwater management and water quality facilities, etc.

Design Criteria –

- (a) Engineering guidelines specifying construction requirements, details and materials.
- (b) Objectives, results or limits which must be met by a facility, structure or process in performance of its intended functions.

Design Storm – see “storm frequency.”

Detention – the slowing, dampening or attenuating of runoff flows entering the natural drainage pattern or storm drainage system by temporarily holding water on a surface area in a detention basin or within the drainage system.

Detention Basin – a pond, basin, reservoir or underground system constructed to impound or retard surface runoff temporarily.

Developer – a person that seeks to undertake or undertakes the activities associated with changes in land use or seeks to undertake or undertakes any regulated earth disturbance activities at a project site in the Borough. The term “developer” includes, but is not limited to, the term subdivider, owner and builder, even though the person involved in successive stages of a project may change or vary over time.

Development – an “earth disturbance activity,” as herein defined and any activity, construction, alteration, change in land use or practice that affects stormwater runoff characteristics. The term also includes redevelopment.

Development Site – the specific tract of land where any development or earth disturbance activities in the Borough are planned, conducted, undertaken or maintained.

Discharge – the flow or rate of flow from a canal, conduit, channel or other hydraulic structure.

Disturbed Area – A land area where an earth disturbance activity is occurring or has occurred.

Drainage – in general, the removal of surface water from a given area commonly applied to surface water and ground water.

Drainage Area – any of the following:

- (a) The area of a drainage basin or watershed, expressed in acres, square miles or other unit of area (also called “catchment area,” “watershed,” “river basin”).
- (b) The area served by a sewer system receiving storm and surface water, or by a watercourse.

Earth Disturbance Activity – a construction or other human activity which disturbs the surface of the land including, but not limited to, clearing and grubbing, grading, excavations, embankments, road maintenance, land development, building construction, oil and gas activities, well drilling, mineral extraction, and the moving, depositing, stockpiling, or storing of soil, rock or earth materials.

Encroachment – any structure or activity which in any manner changes, expands or diminishes, the course, current or cross-section of any watercourse, floodway or body of water.

Erosion – the process by which land, including channels, is worn away by water, wind, or chemical action.

Erosion Control – the application of measures to reduce erosion of land surfaces.

Erosion and Sediment Control Plan – a plan for a project site which identifies BMPs to minimize accelerated erosion and sedimentation of land.

Existing Condition – The dominant land cover during the 5-year period immediately preceding a proposed regulated activity.

FEMA – Federal Emergency Management Agency.

Floodplain – Any land area susceptible to inundation by water from any natural source or delineated by applicable FEMA maps and studies as being a special flood hazard area. Also includes areas that comprise Group 13 Soils, as listed in Appendix A of the Pennsylvania DEP Technical Manual for Sewage Enforcement Officers (as amended or replaced from time to time by DEP).

Floodway – The channel of the watercourse and those portions of the adjoining floodplains that are reasonably required to carry and discharge the 100-year flood. Unless otherwise specified, the boundary of the floodway is as indicated on maps and flood insurance studies provided by FEMA. In an area where no FEMA maps or studies have defined the boundary of the 100-year floodway, it is assumed--absent evidence to the contrary--that the floodway extends from the stream to 50 feet from the top of the bank of the stream.

Forest Management/Timber Operations – Planning and activities necessary for the management of forestland. These include conducting a timber inventory, preparation of forest management plans, silvi-cultural treatment, cutting budgets, logging road design and construction, timber harvesting, site preparation, and reforestation.

Green Infrastructure – Systems and practices that use or mimic natural processes to infiltrate, evapotranspire, or reuse stormwater on the site where it is generated.

Ground Cover – materials and/or vegetation covering the ground surface.

Ground Water – subsurface water occupying the saturation zone, from which wells and springs are fed.

Groundwater Recharge – replenishment of existing natural underground water supplies.

High Tunnel – A structure which meets the following:

- (1) Is used for the production, processing, keeping, storing, sale or shelter of an agricultural commodity as defined in section 2 of the act of December 19, 1974 (P.L.973, No.319), known as the Pennsylvania Farmland and Forestland Assessment Act of 1974, or for the storage of agricultural equipment and supplies.
- (2) Is constructed consistent with all of the following:
 - i. Has metal, wood or plastic frame
 - ii. When covered, has plastic, woven textile or other flexible covering
 - iii. Has a floor made of soil, crushed stone, matting, pavers or a floating concrete slab

Hot Spots - Areas where land use or activities generate highly contaminated runoff, with concentrations of pollutants that are higher than those typically found in stormwater (e.g., vehicle salvage yards and recycling facilities, vehicle fueling stations, fleet storage areas, vehicle equipment and cleaning facilities, vehicle service and maintenance facilities, and certain industrial/commercial activity areas).

Hydrologic Soil Group (HSG) – Infiltration rates of soils vary widely and are affected by subsurface permeability as well as surface intake rates. Soils are classified into four HSGs (A, B, C, and D) according to their minimum infiltration rate, which is obtained for bare soil after prolonged wetting. The NRCS defines the four groups and provides a list of most of the soils in the United States and their group classification. The soils in the area of the development site may be identified from a soil survey report that can be obtained from local NRCS offices or conservation district offices. Soils become less permeable as the HSG varies from A to D (NRCS1,2).

Impervious Surface – a surface that prevents the infiltration of water into the ground. Impervious surfaces (or areas) shall include, but not be limited to: roofs, additional indoor living spaces, patios, garages, storage sheds, and similar structures; and any new streets or sidewalks. Decks, parking areas, gravel areas, and driveway areas are counted as impervious areas if they directly prevent infiltration.

Infiltration – any of the following activities:

- (a) The flow or movement of water through the interstices or pores of a soil or other porous medium.
- (b) The absorption of liquid by the soil.

Land Development – any of the following activities:

- (a) The improvement of one lot or two or more contiguous lots, tracts or parcels of land for any purpose involving:
 - i A group of two or more residential or nonresidential buildings, whether proposed initially or cumulatively, or a single nonresidential building on a lot or lots regardless of the number of occupants or tenure.
 - ii The division or allocation of land or space, whether initially or cumulatively, between or among two or more existing or prospective occupants by means of, or for the purpose of streets, common areas, leaseholds, condominiums, building groups or other features.
- (b) A subdivision of land.

Land Disturbance – any activity involving the changing, grading, transportation, fill and any other activity which causes land to be exposed to the danger of erosion.

Low Impact Development (LID) – Site design approaches and small-scale stormwater management practices that promote the use of natural systems for infiltration, evapotranspiration, and reuse of rainwater. LID can be applied to new development, urban retrofits, and revitalization projects. LID utilizes design techniques that infiltrate, filter, evaporate, and store runoff close to its source. Rather than rely on costly large-scale conveyance and treatment systems, LID addresses stormwater through a variety of small, cost-effective landscape features located on-site.

Maintenance – the upkeep necessary for efficient operation of physical properties.

MS4 (Municipal Separate Storm Sewer System) - A conveyance or system of conveyances (including roads with drainage systems, municipal streets, catch basins, curbs, gutters, ditches, man-made channels, or storm drains):

- (a) Owned or operated by a State, city, town, borough, county, parish, district, association, or other public body (created by or pursuant to State law)...including special districts under State law such as a sewer district, flood control district or drainage district, or similar entity, or an Indian tribe or an authorized Indian tribal organization, or a designated and approved management agency under section 208 of the Clean Water Act that discharges into waters of the United States.
- (b) Designed or used for collecting or conveying stormwater;
- (c) Which is not a combined sewer; and

- (d) Which is not part of a Publicly Owned Treatment Works (POTW) as defined at 40 CFR §122.2.

Municipalities Planning Code – Act 247 of 1968, as amended by Act 170 of 1988, 53 P.S. §10101 *et seq.*

Municipality – Borough of Vandergrift, Westmoreland County, Pennsylvania.

Native Vegetation – Plant species that have historically grown in Pennsylvania and are not invasive species, controlled plants or noxious weeds as defined by PA DCNR, or PA Department of Agriculture.

Natural Stormwater Runoff Regime – a watershed where natural surface configurations, runoff characteristics and defined drainage conveyances have attained the conditions of equilibrium.

NPDES – National Pollutant Discharge Elimination System, the Federal government's system for issuance of permits under the Clean Water Act, which is delegated to DEP in Pennsylvania.

NRCS – Natural Resources Conservation Service (previously Soil Conservation Service).

Outfall – “point source” as described in 40 CFR §122.2 at the point where the Vandergrift Borough storm sewer system discharges to surface waters of the Commonwealth. Also, the point, location or structure where drainage discharges from a sewer, drain or other conduit as well as the conduit leading to the ultimate discharge point.

Outlet Control Structure – the means of controlling the relationship between the head water elevation and the discharge, placed at the outlet or downstream end of any structure through which water may flow.

Overland Flooding – flooding that occurs for a variety of reasons all stemming from excessive stormwater runoff including too much rain in too little time, added impervious development, change in land use, malfunction or clogging of existing stormwater systems.

Peak Discharge – The maximum rate of stormwater runoff from a specific storm event.

Peak Flow – maximum flow.

Pervious Area – Any material or surface that allows water to pass through at a rate equal to or greater than natural ground cover.

Pennsylvania DEP – Pennsylvania Department of Environmental Protection.

Performance Standard – a standard which establishes an end result or outcome which is to be achieved but does not prescribe specific means for achieving it.

Person – an individual, partnership, public or private association or corporation, firm, trust, estate, municipality, governmental unit, public utility or any other legal entity whatsoever which is recognized by law as the subject of rights and duties. Whenever used in any section prescribing or imposing a penalty, the term “person” shall include the members of a partnership, the officers, members, servants and agents of an association, officers, agents and servants of a corporation, and the officers of a municipality or county, but shall exclude any department, board, bureau or agency of the Commonwealth.

Point Source – any discernible, confined and discrete conveyance including, but not limited to, any pipe, ditch, channel, tunnel, or conduit from which stormwater is or may be discharged, as defined in State regulations at 25 Pa. Code §92.1.

Pollutant Reduction Plan (PRP) – a plan required by the MS4 permit to calculate existing pollutants of concern and the minimum reduction in loading from stormwater discharges, and to select the best management practices to achieve the minimum reductions.

Project Site – the specific area of land where any development or regulated earth disturbance activities in the Borough are planned, conducted, undertaken or maintained.

Qualified Professional – Any person licensed by the Pennsylvania Department of State or otherwise qualified under Pennsylvania law to prepare the Stormwater Management Plans and designs as required by this Ordinance.

Record Drawings – Drawings showing the stormwater management system of a site as built, created after the completion of construction and intended for use as a permanent record of the stormwater management system.

Redevelopment – earth disturbance activities on land which has previously been disturbed or developed.

Regulated Development Activity – Any earth disturbance activities or any activities that involve the change of land cover, alteration or development of land in a manner that may affect stormwater runoff as listed in the Regulated Development Activity table. This includes earth disturbance on any portion of, part, or during any stage of, a larger common plan of development. With regard to road maintenance activities the term only includes activities involving 1 acre or more or earth disturbance. Refer to the Regulated Development Activity Table in Article III of this ordinance.

Release Rate – The percentage of existing conditions peak rate of runoff from a site or subarea to which the proposed conditions peak rate of runoff must be reduced to protect downstream areas.

Release Rate Percentage – the watershed factor determined by comparing the maximum rate of runoff from a subbasin to the contributing rate of runoff to the watershed peak rate at specific points of interest.

Resource Extraction – any activity that involves withdrawing materials from the natural environment.

Retention Basin – a pond, basin, usually enclosed by artificial dikes, that is used to retard stormwater runoff by temporarily storing the runoff and releasing it at a predetermined rate.

Retention Volume/Removed Runoff – The volume of runoff that is captured and not released directly into the surface waters of the Commonwealth during or immediately after a storm event.

Return Period – the average interval in years over which an event of a given magnitude can be expected to recur.

Riparian Buffer – A permanent area of native vegetation including herbaceous material, shrubs and/or trees located adjacent to streams, lakes, ponds and wetlands.

Road Maintenance – earth disturbance activities within the existing road cross-section, such as grading and repairing existing paved and unpaved road surfaces, cutting road banks, cleaning or clearing drainage ditches and other similar activities.

Runoff – that part of precipitation which flows over the land.

Runoff characteristics – the surface components of any watershed which affect the rate, amount and direction of stormwater runoff. These may include, but are not limited to, vegetation, soils, slopes and manmade landscape alterations.

SALDO – Subdivision and land development ordinance.

Sediment – mineral or organic solid material that is being transported or has been moved from its site of origin by air, water or ice and has come to rest.

Sedimentation – the process by which mineral or organic matter is accumulated or deposited by moving water, wind or gravity.

Separate Storm Sewer System – a conveyance or system of conveyances (including roads with drainage systems, municipal streets, catch basins, curbs, gutters, ditches, man-made channels or storm drains) primarily used for collecting and conveying stormwater runoff. Refer to MS4.

Small Project – Regulated development activities that, measured on a cumulative basis from 5 years prior to the application, create additional impervious areas of greater than or equal to 500 square feet and less or equal to than 2,500 square feet or involve earth disturbance activity of an area greater than or equal to 1,000 square feet and less than or equal to 5,000 square feet and which do not involve the alteration of stormwater facilities or water courses.

State Water Quality Requirements – as defined under State regulations– protection of designated and existing uses (See 25 Pa. Code, Chapters 93 and 96)–including:

- (a) Each stream segment in Pennsylvania has a “designated use,” such as “cold water fishery” or “potable water supply,” which are listed in 25 Pa. Code, Chapter 93. These uses must be protected and maintained, under State regulations.
- (b) “Existing uses” are those attained as of November 1975, regardless whether they have been designated in 25 Pa. Code, Chapter 93. Regulated earth disturbance activities must be designed to protect and maintain existing uses and maintain the level of water quality necessary to protect those uses in all streams, and to protect and maintain water quality in special protection streams.
- (c) Water quality involves the chemical, biological and physical characteristics of surface water bodies. After regulated earth disturbance activities are complete, these characteristics can be impacted by addition of pollutants such as sediment, and changes in habitat through increased flow volumes and/or rates as a result of changes in land surface area from those activities. Therefore, permanent discharges to surface waters must be managed to protect the stream bank, streambed and structural integrity of the waterway, to prevent these impacts.

Storage Facility – Any surface or sub-surface facility that stores stormwater runoff, see definitions for “detention basin” and “retention basin.”

Storm Frequency – the average interval in years over which a storm event of a given precipitation volume can be expected to occur. The magnitude and temporal distribution of precipitation from a storm event measured in probability of occurrence (e.g., a 5-year storm) and duration (e.g., 24 hours) used in the design and evaluation of stormwater management systems. Also see Return Period.

Storm Sewer – a sewer that carries intercepted surface runoff, street water and other drainage but excludes domestic sewage and industrial waste.

Stormwater – drainage runoff from the surface of the land resulting from precipitation or snow or ice melt.

Stormwater Collection Systems – natural or manmade structures that collect and transport stormwater through or from a drainage area to the point of final outlet including, but not limited to, any of the following conduits and appurtenant features, canals, channels, ditches, streams, culverts, streets and pumping stations.

Stormwater Management Facility – a constructed measure for detention, retention, infiltration and water quality treatment of stormwater runoff.

Stormwater Management Plan – the plan for managing stormwater runoff rate, volume and water quality as required by the Stormwater Management Act, 32 P.S. §680.1 *et seq.*

Stormwater Management Performance District – an area designated by the Watershed Stormwater Performance District Map which includes standards for stormwater rate, volume and water quality. Refer to Appendix A.

Subdivision – As defined in The Pennsylvania Municipalities Planning Code, Act of July 31, 1968, P.L. 805, No. 247, as amended.

Swale – a low-lying stretch of land which gathers or carries surface water runoff.

SWM – abbreviation for “Stormwater Management”.

USDA – United States Department of Agriculture.

Watercourse – a channel or conveyance of surface water, such as a run, stream or creek, having defined bed and banks, whether natural or artificial, with perennial or intermittent flow.

Waters of the Commonwealth – any and all rivers, streams, creeks, rivulets, impoundments, ditches, watercourses, storm sewers, lakes, dammed water, wetlands, ponds, springs, and all other bodies or channels of conveyance of surface water, or parts thereof, whether natural or artificial, within or on the boundaries of this Commonwealth.

Watershed – the entire region or area drained by a river or other body of water whether natural or artificial. A “designated watershed” is an area delineated by the Pennsylvania DEP and approved by the Environmental Quality Board for which Counties are required to develop watershed stormwater management plans.

Watershed Stormwater Management Plan – the plan for managing stormwater runoff throughout a designated watershed as required by the Pennsylvania Stormwater Management Act (Act 167), 32 P.S. §680.1 *et seq.*

WCD – Abbreviation for the “Westmoreland Conservation District”.

Westmoreland Conservation District – see definition for Conservation District

Wetland – Areas that are inundated or saturated by surface or groundwater at a frequency and duration sufficient to support, and that under normal circumstances do support, a prevalence of vegetation typically adapted for life in saturated soil conditions, including swamps, marshes, bogs, and similar areas.

ARTICLE III Stormwater Management Performance Standards.

§301. Stormwater Management Performance Districts.

For purposes of stormwater management, the Borough of Vandergrift is located entirely with-in the Kiskiminetas Watershed, which includes the Stormwater Management Performance District shown on the map entitled “Vandergrift Borough Performance District Map”, which is hereby adopted as a portion of this Ordinance. For areas not covered by a stormwater performance district, the release rate shall be 80%* of the pre-development peak flow as set by the Borough. For more information refer to www.westmorelandstormwater.org .

**In areas not covered by a Stormwater Performance District, an 80% release rate or less is recommended as a standard. This is to apply a “Factor of Safety” to stormwater calculations; to account for the many variables in site design and stormwater management; and to avoid a land development project inadvertently increasing runoff and causing harm downstream.*

§302. General Requirements.

- A. Preparation and implementation of a Stormwater Management (SWM) Site Plan is required for all regulated activities, unless preparation of a SWM site plan is specifically exempted.
- B. **Projects that propose greater than 1 acre of earth disturbance are subject to NPDES Permit requirements and will require a Stormwater Management Plan.**
- C. No regulated activities, unless exempted, shall commence until the Borough issues written approval of a SWM Site Plan, which demonstrates compliance with the requirements of this Ordinance.
- D. Regulated Development Activities shall be as follows:

REGULATED DEVELOPMENT ACTIVITY TABLE

SWM Plan Requirement	New Impervious Area for New and Redevelopment	Disturbed Area*	Next Steps
Exempt	0 square feet	Less than 1 acre	Comply with Exemption section of this ordinance
No-Harm	Less than 500 square feet for all areas	Less than 1,000 square feet for all areas	Comply with the No-Harm section of this ordinance
Waiver / Modification / Demonstrated Equivalency	Less than 1 acre, subject to municipal approval	Less than 1 acre	Comply with the Waiver / Modification / Demonstrated Equivalency section of this ordinance

Small Project (per definition), refer to Appendix C	500 square feet to 2,500 square feet	1,000 square feet to 5,000 square feet	Submit Small Project Site Plan complete with all attachments
Stormwater Management Plan meeting the Ordinance requirements	Greater than 2,500 square feet if Exempt and Small Project criteria are not met, or if improvements do not meet No-Harm criteria	Greater than 5,000 square feet	Consult a qualified Professional to prepare a Storm Water Management Site Plan

*The above Table is only applicable for projects with earth disturbance less than 1 acre and that have not had cumulative impacts, within 5 years preceding the permit application date, that are in excess of the square foot limits.

§303. Exemption from performance standards.

- A. The following regulated activities are specifically **exempt** from the Stormwater Management Plan preparation and submission requirements articulated in this Ordinance:
1. Agricultural activity limited to plowing or tilling activities, for animal concentrated (heavy) use areas provided the activities are performed according to the requirements of Chapter 102, or Conservation Practices being installed as part of the implementation of a Conservation Plan written by an NRCS or SCS-certified planner. This exemption does not include any other type of earth disturbance subject to NPDES permit requirements such as earth disturbance equal to or greater than one (1) acre.
 2. A high tunnel, if proof is provided that the high tunnel is exempt pursuant to the provisions of Act 15 of 2018. Such an exemption does not exempt high tunnels from other requirements applicable under Federal, State or municipal laws.
 3. Forest management and timber operations, provided the activities are performed according to the requirements of Chapter 102.
 4. Resource extraction activities, provided they are done in accordance with applicable PA DEP regulations.
 5. Roadway resurfacing and maintenance projects, which do not increase impervious area, and underground infrastructure projects are exempt from the provisions of this ordinance, provided the activities meet the requirements of all other municipal, state and federal requirements,
 6. Domestic landscaping and/or vegetable gardening.

7. Voluntary Green Infrastructure (GI) or the retrofit of stormwater management infrastructure as conversion to green infrastructure BMPs to correct existing problems, that are solely intended to better manage runoff from existing development, are not part of new development or redevelopment, and that do not fall under the requirements of this or other development ordinances.
- B. The Borough may deny or revoke any exemption pursuant to this Section at any time for any project that the Borough believes may pose a threat to public health, safety, property or the environment.

§304. *No-Harm Option*

Applicants may request approval of a ‘no-harm option’ regarding stormwater management for their project. ‘No-harm option’ requests must meet the following criteria deemed appropriate by the Borough *and in compliance with all Commonwealth laws and regulations*:

- A. Project located very near or adjacent to the Kiskiminetas River
- B. Project able to discharge directly into an existing flood control feature
- C. Project of a small size <500 square feet of new impervious surface or <1,000 square feet of land use changes. Refer to the Regulated Development Activity Table in Article III this ordinance.
- D. Project will generate less than 0.25 cubic feet per second for the ten year storm peak rate increase as compared to pre-development peak rate
- E. Project is not part of a larger development being ‘piecemealed’ in order to avoid stormwater management regulation
- F. Project is not part of a larger development which has grown ‘piecemeal’ over the past five years without SWM
- G. Project is less than 5 percent (<5%) of a much larger site and is incidental to the much larger site where the larger site already has a functioning SWM system which is NOT causing stormwater runoff or soil erosion problems
- H. Project is not located in a neighborhood, watershed, or location where known stormwater problems exist, such as overland flooding like flooding of structures or roadways.
- I. Project does not discharge to a combined sewer
- J. Project will not degrade water quality of the receiving stream. Refer to the Westmoreland County Integrated Water Resources Plan www.westmorelandstormwater.org for maps of impaired streams to determine if

the project area is not within an impaired stream corridor or provide documentation that further degradation will not occur.

To qualify for the 'No-Harm' option, applicant may, at the request of the Borough, submit calculations, drawings, and details showing that the project meets the above criteria. Projects approved for the 'no-harm' option may be exempted from constructing all or some of the usual stormwater management practices regularly required for similar projects. For projects not approved for the 'No-Harm' option, the applicant will be required to meet one of the other Stormwater Management (SWM) Plan requirements under the Regulated Development Activity Table of Article III of this Ordinance.

No-Harm requests must be reviewed by the municipal engineer (and the WCD if deemed necessary by the Borough) and if determined to be acceptable, shall be approved by the Borough.

§305. *Waivers / Modifications / Demonstrated Equivalency*

- A. If the Borough, in conjunction with the Borough Engineer, the WCD, or the DEP as applicable, determines that any requirement under this Ordinance cannot be achieved for a particular regulated activity, the Borough may, after an evaluation of alternatives, approve measures other than those in this Ordinance, subject to this Section paragraphs B, C and D *and in compliance with all Commonwealth laws and regulations*. The request for a waiver, modification, or demonstrated equivalency shall originate with the Landowner, shall be in writing, include a study of downstream effects, and accompany the Stormwater Management Plan submission to the Borough. The request shall provide the facts on which the request is based, the provision(s) of the Ordinance involved and the proposed modification or demonstrated equivalency. The Borough Engineer and the WCD shall review the request to determine if it meets the requirements of the Ordinance including this Section, paragraphs B, C and D. If acceptable to the Borough and the WCD and the regulated stormwater activity involving earth disturbance is less than one (1) acre, the Borough may grant the waiver or modification. If the regulated stormwater activity involving earth disturbance is equal to or greater than one (1) acre, the plan will be subject to the NPDES requirements of DEP.

- B. Waivers, modifications, or demonstrated equivalency of the requirements of this Ordinance may be approved by the Borough if enforcement will exact undue hardship because of unique physical circumstances or pre-existing site conditions peculiar to the land in question, provided that the modifications or demonstrated equivalency will not be contrary or detrimental to the public interest and shall achieve the intended outcome, and that the purpose of the Ordinance is preserved. Hardship must be due to such unique physical circumstances or pre-existing site conditions and not the circumstances or conditions generally created by the provisions of the Stormwater Management Ordinance; and there is no possibility that the property can be developed in strict conformity with the provisions of the Stormwater Management Ordinance. Cost or financial burden shall not be considered a hardship. Hardship cannot have been created by the landowner or developer. Modification or demonstrated equivalency shall not substantially or permanently impair the appropriate use or development of adjacent

property(s) not under the Landowner's control. Modification or demonstrated equivalency may be considered if an alternative standard or approach will provide equal or better achievement of the purpose of the Ordinance.

- C. No waiver, modification or demonstrated equivalency of any regulated stormwater activity involving earth disturbance greater than or equal to one (1) acre may be granted by the Borough unless that action is approved in advance by the Department of Environmental Protection (DEP) or the Westmoreland Conservation District (WCD).
- D. Applicants may request approval of a demonstrated equivalent stormwater activity for their project in lieu of performing traditional stormwater management. Demonstrated equivalent stormwater activity requests will be evaluated by the Borough Engineer and the WCD on a case-by-case basis. Prior approval of a demonstrated equivalent stormwater activity on a site does not set a precedent for future approval of the same or other alternative activities on any site. The approval of a demonstrated equivalent stormwater activity does not excuse the applicant from following standard E&S and SWM practices as applicable on the original site.
 - 1. Demonstrated equivalent stormwater activities shall only be approved when the following criteria are met:
 - a) Traditional stormwater management activities on the site are precluded by a particular site limitation, such as contaminated soil, steep slopes, existing buildings/infrastructure, combined sewer;
 - b) Construction of traditional stormwater management activities on the site would require extra permits or lead to excessive permitting activities and delays;
 - c) The site in question does not already have a stormwater management problem; and
 - d) The site in question is not already contributing to water quality problems in the receiving stream.
 - 2. Approvable demonstrated equivalent stormwater activities may include the following:
 - a) Restoration of an existing degraded wetland, stream channel, floodplain, or riparian buffer, including daylighting of a stream.
 - b) Restoration, retrofit or upgrade an existing stormwater management feature (inadequate detention pond, for example).
 - c) Creation of new stormwater management features, especially green infrastructure, for a previously unmanaged site.

- d) Provide a water-based benefit to the public other than stormwater management (for example, extend a public sewer to an area not already served).
 - e) Treatment of abandoned mine drainage.
3. The proposal for demonstrated equivalency shall be accompanied by documentation or methodology quantifying the equivalency of the proposed project to what would have been originally required. Acceptable documentation or methodology may include use of the Worksheets and Checklist found in PA DEP NPDES permit application, Appendix D or approved method showing the proposed equivalency:
- a) Controls approximately the same amount of runoff volume as what would originally have been proposed.
 - b) Improves approximately the same amount of runoff quality as would have been originally proposed.
 - c) Is located within an impaired watershed or stream segment which will benefit from the proposed project. Impairment may include stream impairment, reduced stream buffer, and pollutant loading. Refer to the Westmoreland County Integrated Water Resources Plan at www.westmorelandstormwater.org.
4. The demonstrated equivalent stormwater activity shall:
- a) Be constructed concurrently with the project for which it is being applied;
 - b) Be constructed according to plans approved by the Borough and the WCD including any erosion control and stormwater management practices as applicable;
 - c) Obtain all necessary permits;
 - d) Be located on land owned by or controlled by the applicant or by a cooperating public or private entity(s) (school, church, club, municipality, etc.);
 - e) Be protected by a perpetual easement or deed restriction, or landowner agreement;
 - f) Be located in the same general watershed as the project for which it is being applied; and

- g) Have an Operation and Maintenance Plan (O&M) specifying the required operation and maintenance and who is responsible for the required tasks.

§306. *Small Project*

- A. When a regulated development activity (refer to Table in Section 302 of this ordinance) creates impervious area greater than or equal to 500 square feet and less than or equal to 2,500 square feet, or total earth disturbance greater than or equal to 1,000 square feet and less than or equal to 5,000 square feet, the stormwater management requirements are as follows. Refer also to Appendix C.
- B. For new impervious surfaces, the first two (2) inches of runoff shall be permanently removed from the runoff flow, and shall not be released to waters of the Commonwealth. Removal options include reuse, evaporation, transpiration and infiltration.
- C. Facilities, to the greatest extent possible and subject to Borough approval, shall be designed to drain the permanently removed runoff volume in a period no greater than 72 hours. Runoff volumes in excess of two (2) inches shall be safely conveyed to a stable vegetated area, natural watercourse, the curb or gutter line of roadway or existing storm collection/conveyance/control system as applicable.
- D. This method is exempt from the requirements of Section 402 of this ordinance.
- E. A Small Project Stormwater Management Plan must be submitted to the Borough and the WCD and shall consist of the following items and related support material needed to determine compliance with Sections 307 to 311 of this ordinance. The applicant can also use protocols listed in Appendix C.
 - 1. Narrative: General description of proposed stormwater management techniques, including calculations, assumptions and criteria used in the design of the stormwater management facilities and BMPs, and construction specifications of the materials to be used for stormwater management facilities and BMPs.
 - 2. Stormwater Management Plan: Showing locations of all stormwater management facilities and BMPs, especially green infrastructure, limits of disturbance, including the type and amount of proposed impervious area, structures, roads, paved areas and buildings;
 - 3. Small Project Stormwater Management Worksheet;
 - 4. Signed acknowledgement page for operation and maintenance of stormwater facilities and BMPs (Refer to Appendix B); and
 - 5. Erosion and Sediment Control Plan: including all reviews and letters of adequacy from the Conservation District.

- F. Small Project requests shall be reviewed by the municipal engineer (and the WCD if deemed necessary by the Borough) and if determined to be acceptable, shall be approved by the Borough.

§307. General Standards.

- A. Proposed land development must consider avoiding, minimizing, and mitigating impacts to the site that may increase stormwater runoff from the proposed project. Applied sequentially, these three low impact development strategies should be an overall guide as a project is planned and carried out.

- B. The Westmoreland County Integrated Water Resources Plan provides an online decision making tool to assist developers, designers, property owners in addressing all water resources during development and redevelopment and should be consulted. Refer to www.paiwrp.com and www.westmorelandstormwater.org.

- C. The following provisions shall be considered the overriding performance standards against which all proposed stormwater control measures shall be evaluated and shall apply throughout the Borough.
 - 1. Any landowner and any person engaged in the alteration or development of land which may affect stormwater runoff characteristics shall implement such measures as are reasonably necessary to prevent injury to health, safety or other property. For alteration or development taking place in stages, the cumulative development must be used in determining conformance with this ordinance. Such measures shall include such actions as are required:
 - a. To assure that the maximum rate of stormwater runoff is no greater after development, as calculated using the standards in this Ordinance, than prior to development activities for the 2-, 10-, 25-, and 100- year storms. Rainfall data shall be obtained from NOAA Atlas 14 or other source approved by the Borough.
 - b. To manage the water quality, rate and volume and direction of resulting stormwater runoff in a manner which otherwise adequately protects health and property from possible injury.
 - c. To notify adjacent property owners or owners of affected properties of any alteration or increase of stormwater flows.

2. Runoff treatment BMPs must be employed where necessary to ensure the water quality, rate and volume requirements are met.
3. Volume control BMPs shall be used to maintain existing hydrologic conditions for small storm events by promoting groundwater recharge and/or evapotranspiration. Runoff volume controls shall be implemented using the PA DEP Stormwater BMP Manual 2006 or other approved method such as those listed in the following chart:

Acceptable Computation Methodologies for Stormwater Management Plans:

METHOD:	DEVELOPED BY:	APPLICABILITY:
Win TR-20 (or commercial computer package based on TR-20)	USDA NRCS	Applicable where use of full hydrologic computer model is desirable or necessary.
Win TR-55 (or commercial computer package based on TR-55 ie. VT/PSUHM)	USDA NRCS	Applicable for land development plans within limitations described in TR-55
HEC-1, HEC-HMS	US Army Corps of Engineers	Applicable where use of full hydrologic computer model is desirable or necessary.
PennDOT 584 (based on rational method)	PennDOT	Applicable under standards established by PennDOT Not to be used for runoff volume and pond sizing computations.
EFH2	USDA NRCS	Applicable in agricultural areas subject to the program limits.
SWMM	EPA	Applicable in urban and suburban areas subject to limits established by EPA
PA DEP BMP Manual 2006	PA DEP	Applicable under standards established by PA DEP
Other Methods	Varies	Other methodologies approved by the Borough

- D. The project plan shall specify permanent stormwater BMPs to be implemented, operated and maintained to meet legal water quality, rate and volume requirements. If methods

other than low impact development (LID) and green infrastructure methods are proposed to achieve the volume and rate controls required under this ordinance, the SWM Site Plan must include a detailed justification demonstrating that the use of LID and green infrastructure is not practicable.

- E. In order to protect and maintain water quality, additional stormwater runoff created by the development project must be captured, stored and treated. In addition, post construction stormwater infiltration of runoff must replicate preconstruction infiltration of runoff to the maximum extent possible with the exception of **hot spots**. As a minimum, this shall be a volume of additional runoff generated by a 2-year, 24-hour storm. Preferred BMP's for **hot spots** include storm inlet filters, proprietary stormwater quality devices, underground detention tanks, detention ponds with forebays, tree planting, green roof. Permeable pavement, infiltration BMP's, and rain gardens are not recommended for hot spots.
- F. In addition to the provisions set forth in paragraphs A. through C., inclusive, as set forth above, all regulated development activities within the Borough shall be designed, implemented, operated and maintained to meet the purposes of this Ordinance, through these two elements:
 - 1. Erosion and sediment control during the earth disturbance activities (e.g., during construction).
 - 2. Water quality, rate and volume protection measures after completion of earth disturbance activities (e.g., post-construction stormwater management), including operations and maintenance.
- G. No regulated development activities within the Borough shall commence until the requirements of this Ordinance are met.
- H. All Best Management Practices (BMP's) used to meet the requirements of this Ordinance shall conform to the State water quality requirements, and any more stringent requirements as determined by the Borough Engineer.
- I. LID and green infrastructure techniques described in the PA DEP Stormwater BMP Manual 2006 or most current edition are encouraged.
- J. Projects proposed in municipalities which are subject to the MS4 regulations must comply with that Borough's approved MS4 permit, including compliance with the six Minimum Control Measures (MCM's) and with the Borough's Pollutant Reduction Plan (PRP).

§308. Watershed Standards

- A. The stormwater management performance standards in this Ordinance are intended to implement the provisions, standards and criteria contained in the Pennsylvania Stormwater Management Act (Act 167), 32 P.S. §680.1 *et seq.* If there is any discrepancy

between the provisions of this Ordinance and the provisions, standards and criteria of the Act, or if a stormwater management plan is subsequently approved and adopted by the appropriate governmental agency or body, then the provisions, standards and criteria of the current watershed plan shall govern.

- B. Management of stormwater runoff is the key objective of 25 Pa. Code, Chapter 93, of the DEP Regulations, because runoff can change the physical, chemical and biological integrity of waterbodies thereby impacting rate, volume and water quality.
- C. The project plan shall describe how these rate, volume and water quality protection requirements will be met. Infiltration BMPs shall be evaluated and utilized to the maximum extent possible to manage the net change in stormwater runoff generated so that post construction discharges do not degrade the physical, chemical or biological characteristics of the receiving waters. These BMPs may be used to satisfy all or part of the requirements found within this Ordinance.
- D. Refer to the Stormwater Performance Districts outlined in Appendix A, and the Westmoreland County Integrated Water Resources Plan (IWRP) at www.westmorelandstormwater.org . The project plan shall describe how the proposed project will address performance standards, impairments, and pollutant loading found in the IWRP. For areas not covered by a stormwater performance district, the release rate shall be eighty percent (80%) of the pre-development peak flow as set by the Borough.

§309. *Design Criteria for Stormwater Management Facilities and BMPs.*

A. *General Criteria.*

- 1. Applicants may select runoff control techniques, or a combination of techniques, which are most suitable to control stormwater runoff from the development site. Refer to the Acceptable Computation Methodologies table of this ordinance. All controls must be subject to approval of the Borough Engineer and the WCD. The Borough Engineer may request specific information on design and/or operating features of the proposed stormwater controls in order to determine their suitability and adequacy in terms of the standards of this Ordinance.
- 2. If the proposed development site is located in an impaired water shed according to Category 4 of the PA Integrated Water Quality Monitoring and Assessment Report, or in a watershed with a TMDL according to Category 5 of the same Report, the applicant shall identify the source and cause of impairment and shall propose, if required or applicable the use of BMP's to mitigate any impacts to the waters.
- 3. The applicant should consider the effect of the proposed stormwater management techniques on any special soil conditions or geological hazards which may exist on the development site. In the event such conditions are identified on the site, the Borough Engineer may require in depth studies by a competent geotechnical

engineer. Not all stormwater control methods may be advisable or allowable at a particular development site.

4. The applicant shall consider the effect of the proposed stormwater management techniques on existing stream impairments and pollutant loading. Refer to the Westmoreland County Integrated Water Resources Plan (IWRP) at www.westmorelandstormwater.org.
5. The applicant shall consider existing conditions on the site for the prior [five] years to determine prevailing land use and impervious cover, and shall consider 20% of existing impervious cover as meadow for pre-existing conditions on redevelopment sites.
6. The stormwater management practices to be used in developing a stormwater management plan for a particular site shall be selected according to the following order of preference:
 - a. Site planning for locating proposed buildings, impervious areas and grading which minimizes disruption of the natural site characteristics especially utilizing low impact development techniques.
 - b. Minimization of impervious areas and promotion of retentive grading.
 - c. Implementation of non-structural measures (refer to the PA DEP Stormwater BMP Manual 2006 or current edition).
 - d. Implementation of innovative / green infrastructure structural measures (refer to the PA DEP Stormwater BMP Manual 2006 or current edition).
 - e. Stormwater detention/retention structures.
7. Any BMP which is a dam, culvert, stream obstruction or encroachment or outfall as defined in 25 Pa. Code, Chapter 105, shall be designed according to the requirements in those regulations.
8. Drainage easements shall be provided for all stormwater conveyance and BMPs serving multiple properties and not located within a public right of way. Easements shall include ingress and egress to a public right of way, and shall be recorded at the County with the final plan. Terms of easement shall prohibit excavation or placement of fill or structures and any alteration that may adversely affect the flow of stormwater within any portion of the easement.

9. No person shall install, create, modify, remove, fill, landscape or otherwise alter or place any structure, soil, rock, material or vegetation in or on, or otherwise adversely affect, any stormwater management facility or any area within a stormwater easement without the written approval of the Borough and approval of the WCD.
 10. Persons engaged in land development activities shall provide the required financial Security and O&M Agreements to the Municipality as outlined in the Appendix B.
- B. *Criteria for Stormwater Management Facilities and BMP's.*
1. If stormwater management facilities and BMPs are utilized for the development site, the facility(s) shall be designed such that post-development peak runoff rates from the developed site are controlled to those rates defined by a Stormwater Management Performance District for the 2-, 10-, 25-, and 100- year storm frequencies. Rainfall data shall be obtained from NOAA Atlas 14 or other source as approved by the Borough.
 2. All stormwater management facilities and BMPs shall be equipped with outlet and overflow structures to provide rate discharge control for the designated storm frequencies. Provision shall also be made to safely pass the entire post-development 100-year storm without breaching or otherwise damaging the facilities, downstream or neighboring properties.
 3. Release of stormwater flow from a development site must be to an existing stormwater conveyance or easement whether natural or man-made. Calculations and information shall be presented as to the ownership, responsible party, capacity, and stability of such conveyance. Release of 'sheet flow' as from a level spreader, will be permitted on a case-by-case basis as approved by the Borough and the WCD.
 4. All stormwater management facilities and BMPs shall be designed to control volume and water quality as defined by the Stormwater Management Performance District. Refer to Appendix A.
 5. Shared stormwater management facilities and BMPs, which provide control of runoff for more than one development site within a single subarea may be considered and are encouraged. Such facilities shall meet the criteria contained in this Section. In addition, runoff from the development sites involved shall be conveyed to the facility in a manner that avoids adverse impacts (such as flooding or erosion) to channels and properties located between the development site and the shared storage facilities.

6. Where stormwater management facilities and BMPs will be utilized, multiple use facilities, such as wetlands, lakes, ballfields or similar recreational/open space uses are encouraged wherever feasible, subject to the approval of the Borough.
7. Other considerations which shall be incorporated into the design of the stormwater management facilities and BMPs include:
 - a. Inflow and outflow structures shall be designed and installed to prevent erosion and embankments, cuts, fills and bottoms of impoundment type structures should be protected from soil erosion.
 - b. Control and removal of debris both in the storage structure and in inlet or outlet devices shall be a design consideration.
 - c. Inflow and outflow structures, pumping stations and other structures shall be designed and protected, using safety benches, trash racks, energy dissipaters and other means to minimize safety hazards.
 - d. Access may be restricted as specified by other Vandergrift Borough Ordinance(s) relating to the provisions for fencing of swimming pools and in appropriate instances such restriction of access may include fencing in a minimum height of six (6) feet.
 - e. Interior slopes of storage ponds shall not exceed a ratio of three to one horizontal to vertical dimension with a combination of interior and exterior slopes not exceeding five. Steeper slopes may be approved by the Borough Engineer if documented to be stable by a geotechnical analysis prepared by, or under the direction of, and sealed by a licensed geotechnical engineer.
 - f. Pond principal spillways shall consist of a solid reinforced concrete box (riser) that is designed and constructed to control the flow rate out of the detention facility. Non-corrugated plastic pipe may be used for the riser where the riser height is less than three feet and the plastic pipe is properly anchored to prevent horizontal or vertical displacement. The riser shall be joined by a watertight connection to a horizontal reinforced concrete pipe or high-performance polypropylene pipe (barrel) extending through the embankment and outletting beyond the downstream toe of the fill. The capacity of the barrel will be the one-hundred-year post-development flow. The construction materials must be approved by the Borough Engineer.

- g. Pond dam embankments shall consist of all excavation on the project, except such material as may be determined unsuitable by the Borough Engineer, which includes but is not limited to frozen material, organic material, rock in excess of three (3) inches in diameter, construction debris, sandy or other coarse grained soils, non-compactable soils and excessively wet or dry material. Acceptable material shall conform to the current PennDOT Publication 408 section on embankment material or shall be as approved by the Borough Engineer. The pond dam embankment shall be compacted to a minimum 95% standard proctor maximum dry density as per ASTM D698. The embankment shall be constructed and compacted in maximum eight inch (8") lifts and the principle spillway outfall barrel and anti-seep collar(s) shall be constructed integral with the dam embankment construction.
- h. Landscaping shall be provided for the facility which stabilizes disturbed areas and preserves the natural and beneficial values of the surrounding area. Landscaping shall consist of plant species native to southwestern Pennsylvania. No trees or other woody vegetation shall be planted on the fill areas of the pond dam embankment that may result in loosening of the compacted soils of the embankment. Detention basin bottoms shall be vegetated with a diverse native planting mix and may include woody shrubs and meadow/wetland herbaceous plants. Noxious and invasive plants that inhibit plant species diversity shall not be included in the plant mix. PennDOT seed mix Formulas B, C, D and L as per PennDOT Publication 408 latest revision, or approved equivalent mix shall be used for revegetation of embankment areas. Crownvetch and birdsfoot trefoil shall not be used due to their interference with performance of inspections of the dam embankment. For other suitable landscape plant species, refer to Appendix B of the Pennsylvania Stormwater Best Management Practices Manual, latest edition.
- i. Facility shall be located to facilitate maintenance, considering the frequency and type of equipment that will be required.
- j. Underground detention / retention / infiltration facilities shall be equipped with open grate inlet or manhole access to facilitate visual inspections.
- k. Other considerations which should be incorporated into the design of the detention facilities include the following:

- 1) Inflow and outflow structures shall be designed and installed to prevent erosion, and bottoms of impoundment-type structures should be protected from soil erosion.
- 2) All inflow structures into detention/retention ponds shall discharge into a pond forebay designed in accordance with the Pennsylvania Stormwater Best Management Practices Manual, where possible.
- 3) Control and removal of debris both in the storage structure and in all inlet or outlet devices shall be a design consideration.
- 4) Inflow and outflow structures, pumping stations and other structures shall be designed and protected to minimize safety hazards.
- 5) The water depth at the perimeter of a storage pond should be limited to that which is safe for children. This is especially necessary if bank slopes are steep or if ponds are full and recirculating in dry periods. Restrictions of access (fence, walls, etc.,) shall be necessary, depending on the location of the facility.
- 6) A safety bench with a minimum width of four (4) feet shall be provided around the entire interior perimeter of the pond at an elevation of 6 inches minimum above the 2-year peak water surface elevation in the pond.
- 7) An anti-vortex device and trash rack shall be attached to the top of the principal spillway to improve the flow of water into the spillway and prevent floating debris from being carried out of the basin.
- 8) The base of the principal spillway must be firmly anchored to prevent its floating. Computations must be made to determine the anchoring requirements. As a minimum, a factor of safety of 1.25 shall be used (downward forces = 1.25 x upward forces).
- 9) The barrel of the principal spillway, which extends through the embankment, shall be designed to carry the one-hundred-year post-development flow provided by the riser of the principal spillway with the water level at the crest of the emergency spillway. The barrel shall consist of a reinforced concrete pipe or high-performance polypropylene pipe and shall be fully supported along its entire length by a concrete cradle extending to the

centerline of the pipe and projecting horizontally a minimum of 6 inches beyond the outside wall of the pipe and vertically 6 inches below the bottom of the pipe. The connection between the riser and the barrel must be watertight. The outlet of the barrel must be protected to prevent erosion or scour of downstream area. This will include an end section or end wall with a designed rip-rap apron. For principle spillway barrels that pass through compacted fill pond dam embankments, the barrel, cradle and anti-seep collar(s) shall be constructed integral with the dam embankment construction as opposed to cutting into the completed dam embankment to construct the barrel etc.

- 10) Anti-seep collars.
 - i Anti-seep collars shall be used on the barrel of the principal spillway within the normal saturation zone of the embankment to increase the seepage length by at least 10% if either of the following conditions is met:
 1. The settled height of the embankment exceeds 10 feet.
 2. The embankment has a low silt clay content and the barrel is greater than 10 inches in diameter.
 - ii The anti-seep collars shall be installed within the saturated zone. The maximum spacing between collars shall be 14 times the projection of the collar above the barrel. Collars shall not be closer than two feet to a pipe joint. Collars should be placed sufficiently far apart to allow space for hauling and compacting equipment. Collars shall consist of reinforced concrete with a minimum thickness of 8 inches. Connections between the collars and the barrel shall be watertight.
- 11) The emergency spillway shall consist of an open channel having a control section at least 10 feet in length. The control section is a level portion of the spillway channel at the highest elevation in the channel. The emergency spillway shall be designed to carry the peak rate of runoff expected from the entire post-development 100-year storm to the stormwater facility. The spillway channel shall be located so as to avoid sharp turns or bends. The channel

shall return the flow of water to a defined channel downstream from the embankment. At the discretion of the Borough Engineer and/or WCD, the emergency spillway shall include a reinforced concrete grade control wall extending perpendicular to the flow through the spillway with the top of the wall flush with the spillway crest. This control wall shall have a minimum width of 8 inches, extend a minimum of 18 inches below the spillway crest and have a length no less than the width of the emergency spillway opening at the top of dam. The emergency spillway shall provide a minimum one (1) foot of freeboard between the water surface of the full 100-year post-development discharge through the spillway and the top of the dam embankment.

C. Criteria for Collection/Conveyance Facilities.

1. All stormwater runoff collection or conveyance facilities, whether storm sewers or other open or closed channels, shall be designed in accordance with the following basic standards:
 - a. All building sites shall use measures to provide drainage away from and around the structure in order to prevent any potential flooding damage as much as practical. Such measures shall include grading the surrounding lawn or pavement area so that it slopes away from the structure by a minimum of five percent (5%) slope over a minimum distance of ten (10) feet; raising the floor of the structure so that it is a minimum of six (6) inches above the predominate surrounding land elevation and above the designated floodplain elevation for those located within a floodplain; eliminating or waterproofing penetrations thru the structure's walls or foundation; constructing berms, curbs, or swales to divert surface water around the structure; arranging roof and area drains to carry water away from the structure.
 - b. Developers proposing a land development or subdivision shall arrange internal drainage within the subdivision so that surface water is safely directed and channeled away from all structures within and adjacent to the development site.
 - c. Developers shall provide to all persons constructing a structure within a land development site, standards including drawings and specifications to ensure that those persons adhere to the general site plans and stormwater management plans for the development. Persons constructing a structure within a land development site shall submit to the Borough Engineer and the WCD drawings, calculations, and other information when deemed necessary to show how they will meet the stormwater management requirements of the development site.

- d. Lots located on the high side or low side of streets shall extend roof, trench and area drains to a stable vegetated area, natural watercourse, the curb or gutter line of roadway or storm collection/conveyance/control system (if applicable) in accordance with the approved stormwater management plan for the development site.
 - e. For all building sites and lots, the inclusion of rain barrels, rain gardens, drywells and other strategies for infiltration of roof runoff close to its source is encouraged.
 - f. Collection/conveyance facilities should not be installed parallel and less than ten (10) feet from the top or bottom of an embankment, nor greater than or equal to fifteen (15) feet in height to avoid the possibility of failing or causing the embankment to fail, unless documented to be stable by a geotechnical analysis.
 - g. All collection/conveyance facilities shall be designed to convey the 25-year storm peak flow rate from the contributing drainage area and to carry it to the nearest suitable outlet such as a stormwater control facility, curbed street, storm sewer or natural watercourse. However, the 100-year design storm may be required as determined by the Borough Engineer where it is necessary for the storm system to convey the 100-year design storm to the stormwater management facility.
 - h. Where drainage swales or open channels are used, they shall be suitably lined to prevent erosion and designed to avoid erosive velocities.
2. Wherever storm sewers are proposed to be utilized, they shall comply with the following additional criteria:
- a. Where practical, designed to traverse under seeded and planted areas. If constructed within ten (10) feet of road paving, walks or other surfaced areas, drains shall have a narrow trench and maximum compaction of backfill to prevent settlement of the superimposed surface or development.
 - b. Preferably installed after excavating and filling in the area to be traversed is completed, unless the drain is installed in the original ground with a minimum of three (3) feet cover and/or adequate protection during the fill construction.
 - c. *Designed.*
 - i. With cradle when traversing fill areas of indeterminate stability.

- ii. With anchors when gradient exceeds 20 percent.
 - iii. With encasement or special backfill requirements when traversing under a paved area.
- d. Designed to adequately handle the anticipated stormwater flow and be economical to construct and maintain. The minimum pipe size shall be fifteen (15) inches in diameter, with the exception of roof drains, foundation drains or similar conveyance.
- e. Drain pipe, trenching, bedding and backfilling requirements and appropriate grates, catch basins, stormwater inlets, manholes and other appurtenances shall conform to the requirements of the Borough and/or applicable PennDOT specifications, Publication 408.
- f. All corrugated metal pipe shall be polymer coated, and with paved inverts where prone to erode. Pipe within a Borough right-of-way shall be reinforced concrete pipe or high-performance polypropylene pipe with a minimum diameter of fifteen (15) inches.
- g. Storm inlets and structures shall be designed to be adequate, bicycle-safe, self-cleaning and unobtrusive and consistent with Borough standards with sufficient capture and conveyance capacity and spacing of inlets and cleanouts for maintenance.
- h. Where a proposed sewer or conveyance connects with an existing storm sewer or conveyance system, the applicant shall demonstrate that sufficient capacity exists in the downstream system to handle the additional flow.
- i. Storm sewer outfalls shall be equipped with energy dissipation devices to prevent erosion and conform with applicable requirements of the Pennsylvania DEP for stream encroachments (Section 7 of the Dam Safety and Encroachments Act, 32 P.S. §693.1, et seq., and the rules and regulations promulgated thereunder at 25 Pennsylvania Code §105.441-105.449) and PA DEP Erosion and Sediment Control Manual current edition. Exit velocities of the design storm for the stormwater conveyance systems must be considered in the design of the energy dissipation devices.
- j. Storm inlets shall include castings with the message “Dump No Waste. Drains to Stream”, or similar message as approved by the Borough Engineer, cast into or permanently affixed to the casting and positioned in a manner that is legible to pedestrian traffic.

D. *Criteria for Riparian Buffers*

1. If a riparian buffer is required by PA DEP as part of an NPDES permit, then DEP regulations will govern.
2. If a Riparian Buffer is used to meet stormwater management requirements and/or MS4 pollutant load reduction credits it shall meet the following requirements:
 - a. In order to protect and improve water quality, a Riparian Buffer Easement may be created and recorded as part of any subdivision or land development that encompasses a Riparian Buffer.
 - b. Except as required by PA Code Title 25 Chapter 102, the Riparian Buffer Easement shall may be measured to a minimum of 35 feet measured from the top of the nearest bank (on each side), or an average of 35 feet with no distance from top of bank less than 25 feet.
 - c. Minimum Management Requirements for Riparian Buffers:
 - i. Existing native vegetation shall be protected and maintained within the Riparian Buffer Easement.
 - ii. Whenever practicable, invasive vegetation shall be actively removed and the Riparian Buffer Easement shall be planted with native trees, shrubs and other vegetation to create a diverse native plant community appropriate to the intended ecological context of the site.
 - iii. There shall be no earth disturbance beyond which is necessary to establish or maintain a planted buffer.
3. The Riparian Buffer Easement shall be enforceable by the Borough and shall be recorded in the appropriate County Recorder of Deeds Office, so that it shall run with the land and shall limit the use of the property located therein. The easement shall allow for the continued private ownership and shall count toward the minimum lot area a required by Zoning, unless otherwise specified in the Borough Zoning Ordinance.
4. Any permitted use within the Riparian Buffer Easement shall be conducted in a manner that will maintain the extent of the existing 100-year floodplain, improve or maintain the stream stability, and preserve and protect the ecological function of the floodplain.
5. Stormwater drainage pipes and all other linear utility lines as approved by the Borough shall be permitted within the Riparian Buffer Easement, but they shall cross the Easement in the shortest practical distance. Other stormwater

management facilities and BMPs are not permitted within the Riparian Buffer Easement.

6. The following conditions shall apply when public and/or private recreation trails are permitted within Riparian Buffers:
 - a. Trails shall be for non-motorized use only.
 - b. Trails shall be designed to have the least impact on native plant species and other sensitive environmental features.
7. Septic drain fields and sewage disposal systems shall not be permitted within the Riparian Buffer Easement and shall comply with setback requirements established under 25 Pa. Code Chapter 73.

E. *Criteria for Stream Restoration Project*

1. A stream restoration project may eligible for stormwater management and/or MS4 load reduction credits if it meets qualifying criteria set by the Borough and as follows:
 - a. Existing conditions, such as channel or streambank erosion and an actively enlarging or incising urban stream condition, shall be documented prior to restoration.
 - b. Projects should be located on 1st to 3rd order (small) streams to be effective.
 - c. Project should address a minimum of 100 linear feet of stream channel and both sides where need to do so is evident.
 - d. Upstream impervious area should be sufficiently treated to address peak flows that may exceed engineering design thresholds or compromise channel form and function.
 - e. Utilize a comprehensive approach employing a mix of techniques appropriate to the site, creating long-term stability of the streambed, streambanks and floodplain.
 - f. Armored length of streams (i.e. using riprap or gabions) may be used to maintain channel stability, but the same length shall not be included in the load reduction calculation.
 - g. Project shall maximize floodplain reconnection, with minimal channel invert elevation increase (i.e. bank height ratio = 1.0 or less) to achieve the objective.

- h. Project shall include a minimum 35 ft permanent riparian buffer.
- i. Project shall include an O&M plan identifying O&M activities, frequencies and responsible parties.

§310. *Erosion and Sedimentation Controls.*

- A. No regulated development activities within the Borough shall commence until approval by the Borough and the WCD of an erosion and sediment control plan for construction activities.
- B. Any earth disturbance activity of 5,000 square feet or more requires an erosion and sedimentation control plan under 25 Pa. Code §102.4(b). Refer to the PA DEP Erosion and Sediment Pollution Control Manual 2012 or most recent version.
- C. In addition, under Title 25 Pa. Code, Chapter 92, a DEP NPDES construction activities permit is required for regulated development activities, involving 1 acre or more of disturbance.
- D. Evidence of any necessary permit(s) for regulated development activities from the appropriate DEP regional office or Westmoreland Conservation District must be provided to the Borough. The issuance of an NPDES construction permit (or permit coverage under the Statewide General Permit (PAG-2) may satisfy the requirements under subsection 1. upon review and approval by the Borough.
- E. A copy of the erosion and sediment control plan and any permit required by DEP or the Borough shall be available at the project site at all times.

§311. *Water Obstructions and Encroachments*

- A. No regulated development activities which require Chapter 105 (Water Obstructions and Encroachment) permit from either PA DEP or Westmoreland Conservation District shall commence until all permits have received PA DEP or WCD approval, and Borough approval.
- B. Evidence of any necessary Chapter 105 permit from PA DEP / WCD shall be provided to the Borough.
- C. Proposed development shall avoid the long and short term adverse impacts associated with the occupancy and modification of floodplains as designated by FEMA, to the extent possible wherever there is a practicable alternative in order to reduce the risk of flood loss, minimize the impacts of floods on human safety, health and welfare, and restore and preserve the natural and beneficial values served by flood plains.

- D. Any proposed development found to be within the base floodplain of a waterway shall include the identification of impacts, an evaluation of practicable alternatives outside the floodplain, and when impacts cannot be avoided, the development of measures to minimize the impacts and restore and preserve the floodplain as appropriate. Findings shall be presented at a public meeting and a determination made by the Council of the Borough of Vandergrift.
- E. Any proposed stormwater management plan should be consistent with the provisions of the PA Floodplain Management Act 166 of 1978 and applicable Borough floodplain ordinances.
- F.

ARTICLE IV Stormwater Management Plan Requirements.

§401. General Requirements.

- A. No development plan, subdivision plat or land development plan shall be approved; no permit authorizing construction or development issued; nor any earth disturbance activity subject to this Ordinance shall be initiated or undertaken unless and until a stormwater management plan for such activity is reviewed and approved in accord with the provisions of this Ordinance.
- B. No regulated development activities within the Borough shall commence until approval by the Borough of a stormwater management plan which demonstrates compliance with State water quality requirements after construction is complete. Refer to the Regulated Development Activity Table located in Article III of this ordinance.
- C. The stormwater management plan must be designed, implemented and maintained to meet State water quality requirements, and any other more stringent requirements as determined by the Borough.
- D. To control post-construction stormwater impacts from regulated development activities, State water quality requirements can be met by BMPs, including site design and green infrastructure, which provide for replication of pre-construction stormwater infiltration and runoff conditions, so that post-construction stormwater discharges do not degrade the physical, chemical or biological characteristics of the receiving waters. As described in the DEP Comprehensive Stormwater Management Policy (#392-0300-002, September 28, 2002), this may be achieved by the following:
 - 1. *Infiltration.* Replication of pre-construction stormwater infiltration conditions.
 - 2. *Treatment.* Use of water quality treatment BMPs to ensure filtering out of the chemical and physical pollutants from the stormwater runoff.
 - 3. *Streambank and Streambed Protection.* Management of volume and rate of post-construction stormwater discharges, using detention / retention

and other means, to prevent physical degradation of receiving waters (e.g., from scouring).

- E. In the absence of an existing stormwater conveyance or easements whether natural or man-made for release of stormwater flow from a development site, easements must be provided. Information shall be presented as to the ownership, responsible party, and agreement for said easements.
- F. The stormwater management plan must meet DEP regulations that require municipalities to ensure design, implementation and maintenance of best management practices (“BMPs”) that control runoff from new development and redevelopment after regulated development activities are complete. These requirements include the need to implement post-construction stormwater facilities and BMPs with assurance of long-term operations and maintenance of those BMPs.
- G. Evidence of any necessary permit(s), such as Chapter 102 erosion and sedimentation control or Chapter 105 stream encroachment, for regulated development activities from WCD or the appropriate DEP regional office must be provided to the Borough. The issuance of an NPDES construction permit (or permit coverage under the Statewide General Permit (PAG-2) may satisfy the requirements of paragraph (A) above, after review and approval by the Borough.
- H. Appropriate sections from the Borough’s Subdivision and Land Development Ordinance (SALDO), and other applicable local ordinances, shall be followed in preparing the SWM Plans.
- I. The Borough shall not approve any SWM Plan that is deficient in meeting the requirements of this Ordinance. At its sole discretion and in accordance with this Article, when a SWM Plan is found to be deficient, the Borough may either disapprove the submission and require a resubmission, or in the case of minor deficiencies, the Borough may accept submission of modifications.
- J. *Professional Certification.* The stormwater management plan (including all calculations) must be prepared and sealed by a qualified professional with training and expertise in hydrology and hydraulics. Documentation of qualifications may be required by the Borough.

§402. Stormwater Management Plan Contents.

General Format. The stormwater management plan shall include a narrative and a set of plan drawings. Refer to sample checklist in Appendix D.

- A. A narrative describing the overall stormwater management concept for the project.

1. A determination of site conditions in accordance with the PA DEP Stormwater BMP Manual. A detailed site evaluation shall be completed for projects proposed environmentally sensitive areas, such as brownfields.
 2. *Runoff Calculations.* Stormwater runoff design calculations for determining pre- and post-development discharge rates, for designing proposed stormwater control facilities and to demonstrate that the maximum practicable measures have been taken to meet the requirements of this Ordinance, must be submitted with the stormwater management plan. All calculations shall be prepared using the methods and data prescribed by general requirements in Section [302]. Refer to the Acceptable Computation Methodologies table in Article III Section 307 of this ordinance.
 - a. Runoff volume and rate shall be calculated according to generally accepted methods such as those listed under Stormwater Management Performance Standards, General Standards.
 - b. Detention/retention requirements, including volume, routing, etc. for BMPs shall be calculated using commonly acceptable standard method(s).
 - c. Water quality calculations shall be determined by using the PA DEP Stormwater BMP Manual 2006 or current edition PA DEP NPDES/PCSM calculation spreadsheets or acceptable alternative method as determined by the Borough or the WCD.
 3. Expected project time schedule for the installation of all temporary and permanent stormwater control measures and devices. If the development is to be constructed in stages, the applicant must describe how stormwater facilities and BMP's will be sequentially installed to manage stormwater runoff safely during each stage of development.
 4. The effect of the project (in terms of runoff rate, volumes, and water quality) on surrounding properties and aquatic features and on any existing stormwater conveyance system that may be affected by the project.
 5. If appropriate, the narrative should provide justification as to why any preferred stormwater management techniques, such as LID and green infrastructure, as listed in this Ordinance, are not proposed for use. Refer to the PA DEP Stormwater BMP Manual 2006 or most recent edition for list of acceptable management techniques.
 6. Operation and maintenance program and responsible party(s) for permanent stormwater facilities and BMP's. Refer to Section VI of this ordinance.
- B. The stormwater management plan drawings shall be drawn to a scale of not less than 1 inch equals 100 feet. All sheets shall contain a title block with name and address of applicant and designer, scale, north arrow, legend and date of preparation.

1. *Existing and Proposed Features.* The plan shall show the following:
 - a. *Watershed Location.* Provide a key map (using USGS Topo maps) showing the location of the development site within the watershed(s) and watershed subarea(s). On all site drawings, show the boundaries of the watershed(s) and subarea(s) as they are located on the development site and identify watershed name(s) and subarea number(s). Refer to Appendix A Watershed Performance District Maps.
 - b. *Floodplain Boundaries.* Identify 100-year floodplains on the development site (as appropriate) based on the Borough's Flood Insurance Study maps.
 - c. *Natural Features.* Show all bodies of water (natural or artificial), watercourses (permanent and intermittent), swales, wetlands and other natural drainage courses on the development site, or which will be affected by runoff from the development.
 - d. *Soils.* Provide an overlay showing soil types and boundaries within the development site (consult WCD, SCS and U.S. Geological Survey for information).
 - e. *Contours.* Show existing and final contours at intervals of 2 feet; in areas with slopes greater than 15 percent, 5-foot contour intervals may be used.
 - f. *Land Cover.* Show existing and final land cover classifications, including existing and proposed improvements, as necessary to support and illustrate the runoff calculations performed.
 - g. *Drainage Area Delineations.* Show the boundaries of the drainage areas and points of interest employed in the runoff calculations performed.
 - h. *Time of Concentration flow paths.* Show flow paths used for all time of concentration calculations. Identify the different segments of flow path used for travel time calculations for sheet flow, shallow concentrated flow and channel flow regimes.
 - i. *Utilities and easements.* Show any existing utilities, stormwater management or drainage controls and/or structures, such as sanitary sewers, water, gas, electric,

telecommunications, storm sewers, swales, culverts, and any easements, which are located on the development site, or which are off site but may be affected by runoff from the development.

2. *Proposed Stormwater Facilities and BMPs.* All proposed stormwater runoff control measures must be shown on the plan including methods for collecting, conveying and storing stormwater runoff onsite, which are to be used both during and after construction. Erosion and sedimentation controls shall be shown in accordance with applicable municipal and WCD requirements. The plan shall provide information on the exact type, location, sizing, design and construction of all proposed facilities and relationship to the existing watershed drainage system.
 - a. If the development is to be constructed in stages, the applicant must demonstrate that stormwater facilities will be installed to manage stormwater runoff safely during each stage of development.
 - b. A schedule for the installation of all temporary and permanent stormwater control measures and devices shall be included in the narrative and shown on the site plan. This schedule shall include all stages of construction identified as critical for the proper short-term and long-term operation and performance of these control measures that will need to be inspected by the stormwater design engineer, the Borough Engineer and/or the WCD.
 - c. Operation and maintenance program and responsible party(s) for permanent stormwater BMPs. Refer to Section VI of this ordinance.
3. *Easements, Rights of Way, Deed Restrictions.* BMPS and stormwater management facilities that provide control for more than one lot shall be located on a separate dedicated lot or in an easement. All existing and proposed easements for any BMPs and stormwater management facilities and controls for access, inspections, maintenance, repair, preservation and use shall be shown on the plan and, if required, dedicated to the entity, association or person required. The easement and the purpose for the same shall be set forth on the plan and in the agreement required by the Ordinance.

§403. *Other Permits/Approvals.*

A list of any approvals/permits relative to stormwater management that will be required from other governmental agencies (e.g., Chapter 102 Erosion and Sedimentation Control, PennDOT HOP, Chapter 105 Water Obstruction and Encroachment Permit from PA DEP) and anticipated dates of submission/receipt should be included with the stormwater plan submission. Copies of

permit applications may be requested by the Borough where they may be helpful for the plan review.

§404. *Operation and Maintenance Plan.*

The application shall contain a proposed operation and maintenance plan (O&M) for all stormwater control facilities in accordance with the following and as described in Article VI of this ordinance:

- A. Identify the responsible party and their responsibilities as described in Article VI Section 601 (e.g., municipality, property owner, private corporation, homeowner's association or other entity).

- B. Include an operation and maintenance plan for all stormwater facilities, outlining the routine maintenance actions and schedules necessary to ensure proper operation of the stormwater control facilities as described in Article VI Section 602.

- C. Submit any legal agreements required to implement the maintenance program and copies of the maintenance agreement as required by this Ordinance. Refer to Article VI Section 603.

- D. Identify method of financing continuing operation and maintenance if the facility is to be owned by other than the Borough or governmental agency. Refer to Article VI Section 604.

§405. *Financial Guarantees*

Submit financial guarantees for timely installation, proper construction and structural integrity (maintenance guarantee) of stormwater facilities and BMP's as specified in Article VII of this ordinance.

ARTICLE V Stormwater Management Plan Submission and Review Procedures.

§501. *Preapplication Phase.*

- A. The Westmoreland County Integrated Water Resources Plan provides an online decision-making tool to assist developers, designers, property owners in addressing all water resources during development and redevelopment and should be consulted. Refer to www.paiwrp.com for the decision-making tool and www.westmorelandstormwater.org.

- B. Applicants should refer to the Westmoreland County Integrated Water Resources Plan (IWRP) located at www.westmorelandstormwater.org, for mapping of impaired streams, riparian buffers and pollutant loading to determine appropriate BMPs to address sources of impairments.

- C. Before submitting the stormwater management plan, and any other plan required by a reviewing agency, applicants are urged to consult with the Borough, Westmoreland County Department of Planning and Development and Westmoreland Conservation District, and PennDOT where applicable, on the requirements for safely managing the development site in a manner consistent with the Borough ordinances, applicable watershed stormwater management plan and Federal and State requirements. These agencies may also be helpful in providing necessary data for the stormwater management plan.
- D. Applicants are encouraged to submit a sketch plan with a narrative description of the proposed stormwater management controls for general guidance and discussion with the Borough and other agencies.
- E. The pre-application phase is not mandatory; any review comments provided by the Borough or other agencies are advisory only and do not constitute any legally binding action on the part of the Borough or any County agency.

§502. Stormwater Management Plan Submission and Review.

- A. *Submission of Plans.* Stormwater management plan application shall be submitted with the preliminary and final subdivision/land development applications or if no subdivision or land development is involved, then with the application for development.

Copies of the SWM Site Plan shall be submitted to the following agencies as determined by the Borough of Vandergrift

1. Two copies to the Municipality(ies).
 2. One copy to the Municipal Engineer.
 3. One copy to the Westmoreland Conservation District.
 4. One copy to the local Sanitary Authority (when applicable).
 5. One copy to the Westmoreland County Department of Planning and Development (when applicable).
 6. One copy to the Westmoreland County Department of Public Safety / local emergency management coordinator (when applicable).
 7. One copy to DEP (when applicable).
- B. *Notification of Affected Municipalities.* The Borough shall notify municipalities upstream and downstream of the development site which may be affected by the stormwater runoff and proposed controls for the site. Copies of the plans will be made available to the affected municipalities upon request. Comments received from any affected

municipalities will be considered by the Borough Engineer and County agencies in their reviews.

- C. *Review by Borough Engineer and Westmoreland Conservation District (WCD).* Stormwater management plans shall be reviewed by the Borough Engineer and WCD. BMP's shall be shown on all stormwater management plans and erosion and sedimentation control plans, as applicable. At its discretion, the Borough and/or WCD may also engage other specialists in hydrology or hydraulics to assist with the stormwater management plan review. The WCD will review the plan for general compliance with the watershed plan standards and criteria and watershed-wide impacts and, where appropriate, may consult with adjacent municipalities and counties for their comments. If the WCD review identifies the improper application of the watershed standards and criteria or the possibility of harmful impacts downstream from the development site's proposed stormwater management system, the applicant and Borough Engineer will be notified so that the necessary modifications can be made to promote safe stormwater management.

The Borough and the WCD shall notify the applicant in writing within 45 days whether the SWM site plan is approved or disapproved. If the SWM site plan involves a subdivision and land development plan, the notification shall occur within 90 days, unless the applicant is notified that a longer notification period is provided by other statute regulation or ordinance. If modifications are required, the review period may be extended by the Borough and the WCD, in order for the applicant to address inadequacies.

- D. A disapproved stormwater management plan may be resubmitted, with the revisions addressing the Borough's and/or WCD's concerns, to the Borough and the WCD in accordance with this article.
- E. *Borough Engineer Review.* The Municipal Engineer shall approve or disapprove the stormwater management plan based on the requirements of the Borough ordinances, the standards and criteria of the watershed plan, applicable State and Federal requirements and good engineering practice. The Borough Engineer shall submit a written report, along with supporting documentation, stating the reasons for approval or disapproval.
- F. *Status of the Engineer's Determination.* The approval/disapproval of the site's stormwater management plan by the Borough Engineer shall be submitted to the Vandergrift Borough Council for final action. Final approval of the plan rests with the Borough.
- G. *Permits Required From Other Governmental Agencies.* Where the proposed development requires a permit from the Pennsylvania DEP, PennDOT, or an erosion/sedimentation permit or Chapter 105 permit from the Westmoreland Conservation District, then final stormwater management plan approval shall be

conditional upon receipt of such permits. However, no building permit shall be issued, nor construction or development started, until the permits are received and copies filed with the Borough.

- H. Reviews by the Borough and WCD will be subject to fees as outlined in Article VII section 706 of this Ordinance.

§503. *Status of Stormwater Management Plan after Approval.*

- A. Upon final stormwater management plan approval and receipt of all necessary permits, financial guarantees and agreements, the applicant may commence to install or implement the approved stormwater management plan, BMP's plan or erosion and sedimentation plan controls.
- B. If site development or building construction does not begin within two (2) years of the date of final approval of the stormwater management plan, then before doing so, the applicant shall re-submit the stormwater management plan, BMP's plan or erosion or sedimentation plan to verify that no condition has changed on the property, adjacent to the site or within the watershed that would affect the feasibility or effectiveness of the previously approved stormwater management controls. Further, if for any reason development activities are suspended for two (2) years or more, then the same requirement for re-submission of the stormwater management plan shall apply.

§504. *Modification of Stormwater Management Plan.*

If the request for a plan modification is initiated before construction begins, the stormwater management plan must be resubmitted and reviewed according to the procedures, contained in this ordinance.

- A. If the request for a plan modification is initiated after construction is underway, the Borough Engineer and / or the WCD shall have the authority to approve or disapprove the modification based on field conditions; provided:
 - 1. The requested changes in stormwater controls do not result in any modifications to other approved Borough land use/development requirements (e.g., building setbacks, yards, etc.).
 - 2. The performance standards in this Ordinance are met. Notification of the Borough Engineer's and / or WCD's action shall be sent to the Vandergrift Borough Council which may issue a stay of the plan modification within 5 days and require the permittee to re-submit the plan modification for full stormwater management plan review in accordance with this ordinance.
- B. It shall be unlawful to, and no person shall, alter, replace, modify, landscape or remove, or otherwise adversely affect, any permanent stormwater management facilities, BMP

controls, or any area within a stormwater easement or dedicated or designated area for stormwater facilities and BMPs required by an approved stormwater management plan, BMP operations and maintenance plan, or to allow the property to remain in a condition which does not conform to an approved stormwater management plan, BMP operations and maintenance plan, unless an exception is granted in writing by the Borough and/or approval is secured from all relevant agencies of the Commonwealth.

§505. *Inspection of Stormwater Management Facilities and BMPs.*

- A. The Municipal Engineer, or a designated representative thereof, may inspect the implementation, construction, condition, operation and maintenance of the temporary and permanent stormwater management system and controls for the development site. The Borough or a designated representative shall have the right to temporarily locate on any BMP in the Borough such devices as are necessary to conduct monitoring and/or sampling of the discharge from such BMP.

- B. The permittee shall notify the Borough Engineer and the WCD 48 hours in advance of the completion of the following key development phases:
 - 1. At the completion of preliminary site preparation including stripping of vegetation, stockpiling of topsoil and construction of temporary stormwater management control facilities.
 - 2. At the completion of rough grading but prior to placing topsoil, permanent drainage or other site development improvements and ground covers.
 - 3. During construction of the permanent stormwater facilities and BMPs at such times as specified by the Borough Engineer.
 - 4. Completion of permanent stormwater management facilities and BMPs including established ground covers and plantings.
 - 5. Completion of final grading, vegetative control measures or other site restoration work done in accordance with the approved plan and permit.

- C. The Borough Engineer and the WCD may conduct inspections during construction as it deems appropriate.

- D. No work shall commence on any subsequent phase until the preceding one has been inspected and approved. If there are deficiencies in any phase, the Municipal Engineer and/or the WCD shall issue a written description of the required corrections and stipulate the time by which they must be made.

- E. If, during construction, the contractor or permittee identifies any site condition, such as subsurface soil conditions, alterations in surface or subsurface drainage, which could affect the feasibility of the approved stormwater facilities, or erosion and sedimentation controls he/she shall notify the Municipal Engineer and/or the WCD within 24 hours of the discovery of such condition and request a field inspection. The Municipal Engineer and/or the WCD shall determine if the condition requires a modification of the stormwater management plan, BMP's plan or erosion and sedimentation control plan.
- F. In cases where stormwater facilities or erosion and sedimentation controls are to be installed in areas of landslide-prone soils or other special site conditions exist, the Borough and/or the Borough Engineer may require special precautions such as a geotechnical study, soil tests and core borings, additional full-time inspectors and/or similar measures. All costs of any such measures shall be borne by the permittee.

§506. *Record Drawings, Completion Certificate, and Final Inspection*

- A. The developer shall be responsible for providing record drawings of all stormwater management facilities and BMP's as built and included in the approved Stormwater Management Plan. The record drawing for subdivision plans should identify any and all lots that are to have individual on-lot controls (i.e. dry wells, et al) and a description of the type of on-lot control, a typical detail of that control and the basis for their individual design (i.e. storage volume per impervious area), as identified in the approved Stormwater Management Plan for the overall subdivision plan. The record drawings and an explanation of any discrepancies with the construction plans shall be submitted to the Borough Engineer and the WCD.
- B. The record drawing submission shall be in a format as specified by the Borough or the Borough Engineer, shall be in a format that meets the requirements for recording at the Office of the Recorder of Deeds of Westmoreland County and shall include a certification of completion signed by a qualified professional verifying that all permanent stormwater management facilities and BMP's have been constructed according to the approved stormwater management plans, calculations and specifications. The latitude and longitude coordinates for all permanent stormwater management facilities and BMP's must also be submitted, at the central location of the BMP's. If any licensed qualified professionals contributed to the construction plans, then a licensed qualified professional must sign the completion certificate.
- C. After receipt of the completion certification by the Borough, the Borough, the Borough Engineer and/or the WCD may conduct a final inspection.
- D. Once the final inspection has revealed that the facilities have been constructed as per the approved plans and calculations and once the record drawing(s) have been approved and accepted by the Borough, the Borough Engineer and/or the WCD, the owner of the Stormwater Management Facility shall have the record drawing(s) recorded at the Office of the Recorder of Deeds of Westmoreland County and pay all required recording fees.

ARTICLE VI Operation and Maintenance of Stormwater Facilities and BMPs

§601. *Operation and Maintenance Responsibilities.*

- A. The stormwater management plan for the development site shall contain an Operation and Maintenance plan prepared by the developer and approved by the Borough and/or the WCD. The Operation and Maintenance plan shall outline the responsible party(ies) and required routine maintenance actions and schedules necessary to insure proper operation of the stormwater control facility(s).

- B. The stormwater management plan for the development site shall establish responsibilities for the continuing Operation and Maintenance (O&M) of all stormwater facilities and BMP's, consistent with the following:
 - 1. If a development consists of structures or lots which are to be separately owned and in which streets, sewers and other public improvements are to be dedicated to the Borough, stormwater facilities and BMP's should also be dedicated to and maintained by the Borough, except for those individual on-lot facilities and BMP's for privately owned structures.

 - 2. If a development site is to be held in single ownership or if sewers and other public improvements are to be privately owned, operated and maintained, then the Operation and Maintenance of stormwater facilities and BMP's should be the responsibility of the owner or private management entity.

 - 3. Person(s) responsible for Operation and Maintenance of stormwater facilities and BMP's shall be named with contact information provided.

- C. The Vandergrift Borough Council, upon recommendation of the Borough Engineer, shall make the final determination on the continuing maintenance responsibilities prior to final approval of the stormwater management plan. The Vandergrift Borough Council reserves the right to accept or not to accept the ownership and operating responsibility for any or all of the stormwater management facilities and BMP's.

- D. If the development site involves land located in more than one municipality, then the plan shall be reviewed by the municipality and/or the WCD to determine if all activities both within and without the municipality meet the requirements of this Ordinance.

- E. Stormwater facilities and BMP's shall be inspected by the owner/responsible party named in the O&M plan on a regular basis as determined by the Borough or as approved

in the O&M plan. Inspections may include photographs, written reports, measured drawings as necessary to document conditions of the facility(s) and the report shall be provided to the Borough upon request.

§602. *Stormwater Facility and BMP Operation and Maintenance Plan Requirements.*

- A. No regulated development activities within the Borough will be considered complete until approval by the Borough of the BMP Operation and Maintenance plan which describes how the permanent (i.e., post-construction) stormwater facilities and BMP's will be properly operated and maintained.

- B. The following items shall be included in the BMP Operation and Maintenance plan:
 - 1. Map(s) of the project area, in a form that meets the requirements for recording at the Office of the Recorder of Deeds of Westmoreland County, refer to the <http://www.wcdeeds.us/dts/> . The contents of the maps(s) shall include, but not be limited to:
 - a. Ownership and Operation and Maintenance responsibilities of stormwater facilities and BMP's.
 - b. Clear identification of the location and nature of permanent stormwater facilities and BMP's.
 - c. The location of the project site relative to highways, municipal boundaries or other identifiable landmarks.
 - d. Existing and final contours at intervals of 2 feet are required if the general slope of the site is less than 15 percent, and at vertical intervals of 5 feet if the general slope is equal to or greater than 15 percent.
 - e. Existing streams, lakes, ponds, or other bodies of water within the project site area.
 - f. Other physical features including flood hazard boundaries, sinkholes, streams, existing drainage courses, and areas of natural vegetation to be preserved.
 - g. The locations of all existing and proposed utilities, sanitary sewers, and water lines within 50 feet of property lines of the project site.

- h. Proposed final changes to the land surface and vegetative cover, including the type and amount of impervious area that would be added.
 - i. Proposed final structures, roads, bridges, paved areas, and buildings.
 - j. A 15-foot wide access easement around all stormwater facilities and BMP's that would provide ingress to and egress from a public right-of-way.
 - 2. A description of how all permanent stormwater facilities and BMP's will be operated and maintained, and the identity of the person(s) responsible for operations and maintenance.
 - 3. The name of the project site, the name and address of the owner of the property, and the name of the individual or firm preparing the plan.
 - 4. A statement, signed by the landowner, acknowledging that the stormwater facilities and BMPs are fixtures that can be altered or removed only after approval by the Borough.
- C. Each stormwater facility and BMP shall be recorded with the County as permanent real estate appurtenances, and as deed restrictions or conservation easements that run with the land. Prior to final approval of the stormwater plan the property owner shall sign and record an O&M agreement for those facilities and BMP's. Refer to Appendix B of this ordinance.
- D. If the owner fails, refuses or neglects to maintain any stormwater facility and/or BMP, the Borough reserves the right to conduct maintenance work and charge and assess the owner any and all costs, expenses incurred and fees set by the Borough. The Borough reserves the right to take enforcement actions for failure to perform required O&M. Refer to article VIII of this ordinance.
- E. Financial guarantees for timely installation, proper construction and structural integrity (maintenance guarantee) of stormwater facilities and BMP's shall be as specified in Article VII of this ordinance.

§603. *Operation and Maintenance Agreement for Privately Owned Stormwater Facilities and BMPs.*

- A. Prior to final approval of the site's stormwater management plan the property owner shall sign and record a maintenance agreement covering all stormwater facilities and BMP's which are to be privately owned. The agreement (refer to sample agreement in Appendix B) shall stipulate that:

1. The owner, successors and assigns shall maintain all facilities in accordance with the approved maintenance schedule and shall keep all facilities in a safe and functional manner and consistent with the surrounding natural area.
 2. The owner, successors and assigns shall convey to the Borough easements and/or rights-of-way to assure access for periodic inspections by the Borough and maintenance, if required.
 3. The owner, successors and assigns shall keep on file with the Borough the name, address and telephone number of the person or company responsible for maintenance activities; and in the event of a change, new information will be submitted to the Borough within 10 days of the change.
 4. If the owner, or their successors and assigns fail to maintain the stormwater facilities and BMP's following due notice by the Borough to correct the problem(s), the Borough may perform the necessary maintenance work or corrective work and the owner shall reimburse the Borough for all costs.
- B. Other items may be included in the agreement where determined necessary to guarantee the satisfactory inspection and maintenance of all stormwater facilities and BMP's for a ten (10) year period. The maintenance agreement shall be subject to the review and approval of the Municipal Solicitor and the Vandergrift Borough Council and shall be in a form such as may be recorded in the Office of the Recorder of Deeds of Westmoreland County.
- C. The property owner shall sign an Operation and Maintenance agreement with the Borough covering all stormwater facilities and BMP's that are to be privately owned. A sample of such agreement is included in Appendix B of this Ordinance.

§604. *Municipal Stormwater Facility and BMP Operation and Maintenance Fund.*

- A. Persons installing stormwater facilities or BMP's shall be required to pay a specified amount to the Vandergrift Stormwater Facility and BMP Operation and Maintenance Fund to help defray costs of periodic inspections and maintenance expenses. The amount of the deposit shall be determined as follows:
1. If the stormwater facilities and/or BMP's are to be privately owned and maintained, the deposit shall cover the cost of periodic inspections performed by the Borough for a period of 10 years, as estimated by the Borough Engineer. After that period of time, inspections will be performed at the expense of the Borough.

2. If the stormwater facilities and/or BMP's are to be accepted, owned and maintained by the Borough, the deposit shall cover the estimated costs for maintenance and inspections for 10 years. The Municipal Engineer will establish the estimated costs utilizing information submitted by the applicant.
 3. The amount of the deposit to the fund shall be converted to present worth of the annual series values. The Municipal Engineer shall determine the present worth equivalents which shall be subject to the approval of the Vandergrift Borough Council.
- B. If stormwater facilities and BMP's are proposed that also serve as recreation facilities (e.g., ball fields, lakes), the Borough may reduce or waive the amount of the maintenance fund deposit based upon the value of the land for public recreation purposes, or the Borough may accept the maintenance fund deposit on behalf of the agency managing the recreation resource and make said funds available to the agency's maintenance department.
- C. If at some future time stormwater facilities and BMP's (whether publicly or privately owned) are eliminated due to the installation of storm sewers or other stormwater facilities and BMP's, the unused portion of the maintenance fund deposit will be applied to the cost of abandoning the facility and connecting to the storm sewer system or other facility. Any amount of the deposit remaining after costs of abandonment are paid will be returned to the depositor.

ARTICLE VII Fees, Financial Guarantees and Dedication of Public Improvements

§701. *Guarantee of Completion.*

- A. A completion guarantee or financial security in the form of a bond, cash deposit, cashier's check or other negotiable securities acceptable to the Borough shall provide for, and secure to the Borough, the completion of any improvements which may be required on or before the date fixed in the formal action of approval or accompanying agreement for completion of the improvements. The guarantee or security shall cover any and all stormwater management facilities, BMP's, erosion and sedimentation controls and other required improvements (collectively, "improvements") and shall be equal to 110% of the cost of completion estimated as of 90 days following the date scheduled for completion by the developer. Annually the Borough may adjust the amount of financial security by comparing the actual cost of the improvements which have been completed and the estimated cost for the completion of the remaining improvements as of the expiration of the 90th day after either the original date scheduled for completion or a rescheduled date of completion. Subsequent to said adjustment, the Borough may require the developer to post additional security in order to assure that the financial security equals said 110%. Any additional security shall be posted by the developer in accordance with this subsection.

- B. The amount of the completion guarantee or financial security required shall be determined by the Borough Engineer based upon cost estimates provided by the design professional. Any dispute involving the amount of the guarantee or financial security shall be settled utilizing the provisions of §509 (g) of the Municipalities Planning Code.

§702. *Release of Completion Guarantee.*

The completion guarantee or financial security shall be returned or released upon written certification by the Borough Engineer or a designated agent thereof that improvements and facilities have been installed and completed in accordance with the approved plan and specifications and upon receipt of the required record drawings and completion certificate as described in §506 of this Ordinance and receipt of the required structural integrity maintenance guarantee as described in §705 of this Ordinance and upon payment of all applicable costs associated with reviews, approvals and inspections. The procedures for requesting and obtaining a release of the completion guarantee or financial security shall be in a manner prescribed by the §510 of the Municipalities Planning Code.

§703. *Default of Completion Guarantee.*

If improvements are not installed in accordance with the approved final plans, the Council of the Borough of Vandergrift may enforce any corporate bond or any security by appropriate legal and equitable remedies. If proceeds of such bond or other security are insufficient to pay the cost of installing or making repairs or corrections to all the improvements covered by said security, the Vandergrift Borough Council may at its option install part of such improvements in all or part of the development and may institute appropriate legal or equitable action to recover the monies necessary to complete the remainder of the improvements. All proceeds, whether resulting from the security or from any legal or equitable action brought against the developer, or both, shall be used solely for the costs associated with the installation of the improvements covered by such security and not for any other municipal purpose.

§704. *Dedication of Public Improvements.*

- A. When streets, sanitary sewers, stormwater management facilities, BMP's, erosion and sedimentation controls or other required improvements in the development have been completed in accordance with the final plans, such improvements shall be deemed private until such time as they have been offered for dedication to the Borough and accepted by separate ordinance or resolution or until they have been condemned for use as a public facility. The Borough shall be under no obligation to accept such facilities or controls unless and until the Borough so determines that it is in the best interest of the Borough to do so.
- B. Prior to acceptance of any improvements or facilities, the Borough Engineer shall inspect the same to ensure that the same are constructed in accordance with the approved plans and are functioning properly.

C. The owner shall submit as-built plans for all facilities proposed for dedication.

§705. *Maintenance Guarantee.*

Prior to acceptance of any improvements or facilities, the applicant shall provide financial security to secure the structural integrity and functioning of the improvements. The security shall:

- A. Be in the form of a bond, cash, cashier's check or other negotiable securities acceptable to the Borough.
- B. Be for a term of 18 months.
- C. Be in an amount equal to 15 percent of the actual cost of the improvements and facilities so dedicated.

§706. *Fees and Expenses.*

The Borough shall be reimbursed for all internal and external costs incurred in relation to the review, consideration and inspection of Stormwater Management applications and the improvements made thereto and said fees and costs shall be charged to an applicant. The schedule of fees shall be as described in Appendix E of this Ordinance. The Council of the Borough of Vandergrift may by resolution, from time to time, revise and/or amend the schedule of fees to cover the cost of administrative and clerical processing, attendance at meetings including pre-submitted and pre-construction meetings, plan and calculation reviews, O&M plan and agreement reviews, site and construction inspections, post-construction inspections and all activities necessary to administer, monitor and enforce the provisions of this Ordinance. All external fees shall be billed to the applicant at a rate no more than the actual costs charged by professional consultant(s). In the event that the Borough and the applicant cannot agree to the amount of fees, the Borough and the applicant shall select a neutral third-party arbitrator in the same field as the professional consultant, who shall find the fee reasonable or unreasonable. The arbitrator shall be selected by the Borough and the applicant within thirty (30) days of the date the Borough and the applicant reached an impasse on the costs, and the arbitrator shall schedule a hearing on the fee dispute, within thirty (30) days of their selection. The formal rules of evidence shall not apply at said hearing. If the Borough and the applicant cannot mutually select an arbitrator, they shall petition the Court of Common Pleas to select the arbitrator. The arbitrator shall issue a written determination within thirty (30) days of the date of the hearing. If the fees are determined to be reasonable, they shall be the fee charged to the applicant. If the fees are found to be unreasonable, the arbiter shall set the fee. The cost of the arbiter shall equally split between the Borough and the applicant. The decision of the arbiter shall be final and binding upon the Borough and the applicant.

ARTICLE VIII Enforcement Procedures and Remedies.

§801. *Right of Entry.*

Upon presentation of proper credentials, duly authorized representatives of the Borough may enter at reasonable times upon any property to inspect, investigate or ascertain the condition of the subject property in regard to an aspect related to stormwater management regulated by this Ordinance. Prohibitions and unreasonable delays in allowing the Borough access to a stormwater management facility pursuant to this Ordinance is a violation of this Ordinance. The failure of any person or entity to grant entry or to undertake any action which impedes or prevents entry is prohibited and constitutes a violation of this Ordinance. Unless in the event of an emergency, the Borough shall notify the property owner and/or developer within twenty-four hours prior to entry.

§802. *Enforcement Generally.*

- A. It shall be unlawful for a person to undertake any regulated activity except as provided in an approved SWM Site Plan, unless specifically exempted in Article III Section 303 of this Ordinance.
- B. It shall be unlawful to alter any BMP's, facilities or structures that were installed under this Ordinance without written approval of the Borough.
- C. In the event that the applicant, developer, owner or his/her agent fails to comply with the requirements of this Ordinance or fails to conform to the requirements of any permit a written notice of violation shall be issued. Such notification shall set forth the nature of the violation(s) and establish a time limit for correction of the violation(s). Upon failure to comply within the time specified, unless otherwise extended by the Borough, the applicant, developer, owner or his/her agent shall be subject to the enforcement remedies of this Ordinance. Such notice may require without limitation:
 - 1. Whenever the Borough finds that a person has violated a prohibition or failed to meet a requirement of this Ordinance, the Borough may order compliance by written notice to the responsible person. Such notice may require without limitation, any or all of the following:
 - a. The performance of monitoring, analyses, and reporting.
 - b. The elimination of prohibited connections or discharges.
 - c. Cessation of any violating discharges, practices, or operations.

- d. The abatement or remediation of stormwater pollution or contamination hazards and the restoration of any affected property.
 - e. Payment of a fine to cover administrative and remediation costs.
 - f. The implementation of stormwater management measures or facilities.
 - g. Operation and maintenance of stormwater management measures and/or facilities
 - h. Assessment and payment of any and all costs and expenses relative to corrective measures taken or to be taken and reasonable costs, expenses and attorney fees incurred by the Borough in and related to enforcement and collection proceedings.
- 2. Such notification shall set forth the nature of the violation(s) and establish a time limit for correction of these violations(s). Said notice may further advise that, if applicable, should the violator fail to take the required action within the established deadline, the work will be done by the Borough or designee and the expense thereof shall be charged to the violator.
 - 3. Failure to comply within the time specified shall also subject such person to the penalty provisions of this Ordinance. All such penalties shall be deemed cumulative and shall not prevent the Borough from pursuing any and all other remedies available in law or equity.

§803. *Suspension and Revocation*

- A. Any approval or permit issued by the Borough pursuant to this Ordinance may be suspended or revoked for:
 - 1. Non-compliance with or failure to implement any provision of the approved SWM Site Plan or O&M Agreement.
 - 2. A violation of any provision of this Ordinance or any other applicable law, ordinance, rule, or regulation related to the Regulated Activity.
 - 3. The creation of any condition or the commission of any act during the Regulated Activity which constitutes or creates a hazard, nuisance, pollution, or endangers the life or property of others.

- B. A suspended approval may be reinstated by the Borough when:
 - 1. The Borough has inspected and approved the corrections to the violations that caused the suspension.
 - 2. The Borough is satisfied that the violation has been corrected.
- C. An approval that has been revoked by the Borough cannot be reinstated. The applicant may apply for a new approval under the provisions of this Ordinance.
- D. If a violation causes no immediate danger to life, public health, or property, at its sole discretion, the Borough may provide a limited time period for the owner to correct the violation. In these cases, the Borough may provide the owner, or the owner's designee, with a written notice of the violation and the time period allowed for the owner to correct the violation. If the owner does not correct the violation within the allowed time period, the Borough may revoke or suspend any, or all, applicable approvals and permits pertaining to any provision of this Ordinance.

§804. Preventative Remedies.

- A. In addition to other remedies, the Borough may institute and maintain appropriate actions by law or in equity to restrain, correct or abate a violation, to prevent unlawful construction, to recover damages and to prevent illegal occupancy of a building or premises.
- B. The Borough may refuse to issue any permit or grant approval to further improve or develop any property which has been developed in violation of this Ordinance.

§805. Violations and Penalties.

- A. Any person who has violated or knowingly permitted the violation of the provisions of this Ordinance or has refused, neglected or failed to perform any of the actions required pursuant to the Notice set forth in 2.A. above, upon conviction thereof in an action brought before a magisterial district judge in the manner provided for the enforcement of summary offenses under the Pennsylvania Rules of Criminal Procedure, shall be guilty of a summary offense, and shall be sentenced to pay a fine of not less than \$100.00 nor more than \$1,000.00 for each violation, plus costs, together with reasonable attorney fees; and, in default or failure of full and timely payment of such fine, costs and fees, to a term of imprisonment not to exceed ninety (90) days or to a term of imprisonment to the extent permitted by law for the punishment of violations of summary offenses, whichever is less. Each day that a violation of this Ordinance continues or each Section of this Ordinance which shall be found to have been violated shall constitute a separate offense. No judgment shall commence or be imposed, levied or be payable until the date of the determination of a violation by the magisterial district judge. Each day that a

violation of this Ordinance continues or each Section of this Ordinance which shall be found to have been violated shall constitute a separate offense.

- B. If the defendant neither pays nor timely appeals the judgment, the Borough may enforce the judgment pursuant to applicable rules of civil procedure.
- C. Each day that a violation continues shall constitute a separate violation unless the magisterial district judge further determines that there was a good faith basis for the person violating this Ordinance to have believed that there was no such violation. In such case there shall be deemed to have been only one such violation until the fifth day following the date of the district justice's determination of the violation; thereafter each day that a violation continues shall constitute a separate violation.
- D. All judgments, costs and reasonable attorney fees collected for the violation of this Ordinance shall be paid over to the Borough.
- E. The court of common pleas, upon petition, may grant an order of stay, upon cause shown, tolling the per diem fine pending a final adjudication of the violation and judgment.
- F. Nothing contained in this Section shall be construed or interpreted to grant to any person or entity other than the Borough, the right to commence any action for enforcement pursuant to this Section.
- G. Each day that a violation of any provision of this Ordinance shall constitute a separate violation and be deemed a public nuisance.

§806. *Additional Remedies.*

In addition to the above remedies, the Borough may also seek the remedies and penalties under applicable Pennsylvania statutes, or regulations adopted pursuant thereto including, but not limited to, the Stormwater Management Act, 32 P.S. §§693.1 *et seq.*, and the erosion and sedimentation regulations, 25 Pa. Code, Chapter 102. Any activity conducted in violation of this Ordinance or any Pennsylvania approved watershed stormwater management plan may be declared a public nuisance by the Borough and abatable as such.

§807. *Appeals.*

- A. Appeals.
 - 1. Any person aggrieved by a decision of the Borough or any of its authorized persons or agencies, may appeal in writing said decision to the

Vandergrift Borough Council within thirty (30) days of any decision. Any appeal must be filed with the Vandergrift Borough Council.

2. The appellant shall pay to the Borough at the time of filing the appeal, any and all fees and charges as set forth in a Resolution of the Borough.
- B. Procedure. Any Appeal filed pursuant to this section shall be governed by the Local Agency Law of the Commonwealth of Pennsylvania (2 Pa. C.S.A. §105, specifically 2 Pa. C.S.A. §551-§555).
- C. Hearing. The Vandergrift Borough Council shall schedule a hearing within sixty (60) days of receipt of said Appeal. Written notice of the hearing shall be given to the party filing the Appeal and any authorized person or agency of the Municipality involved, not less than fifteen (15) days prior to said hearing.
- D. Hearing Procedure.
1. All testimony may be stenographically recorded and a full and complete record be kept of the proceedings. In the event all testimony is not stenographically recorded and a full and complete record of the proceedings is not provided by the local agency, such testimony shall be stenographically recorded and a full and complete record of the proceedings and shall be kept at the request of any party agreeing to pay the costs thereof.
 2. The Vandergrift Borough Council shall not be bound by technical rules of the evidence at the aforesaid hearing, and all relevant evidence of reasonably probative value may be received. Reasonable examination and cross-examination shall be permitted.
- E. Adjudication.

The adjudication of the Vandergrift Borough Council shall be in writing, shall contain findings and the reasons for the adjudication, and shall be served upon all parties to the Appeal or their counsel personally, or by mail.

F. Appeal from Adverse Adjudication.

Pursuant to 2 Pa. C.S.A. Section 751 et seq. any person aggrieved by the adjudication of Vandergrift Borough Council who has a direct interest in such adjudication shall have the right to appeal therefrom to the Court vested with jurisdiction of such appeals by or pursuant to Title 42 (Relating to Judiciary and Judicial Procedure).

SECTION 2. The terms and provisions set forth herein shall become effective immediately.

SECTION 3. All previously enacted ordinances and resolutions, as well as all provisions of the Code of the Borough of Vandergrift, inconsistent herewith are hereby superseded and null and void.

BE IT ORDAINED, and it is hereby ordained, that Council for the Borough of Vandergrift hereby ADOPTS the within Ordinance this 4th day of January, 2021, a full quorum being present and acting throughout.

BOROUGH OF VANDERGRIFT

By: Kathleen Chvala
Kathleen Chvala, President
Vandergrift Borough Council

ATTEST:

Stephen J. DelleDonne (SEAL)
Stephen J. DelleDonne

APPROVED:

Barbara Turiak
Barbara Turiak, Mayor

REFERENCES

1. U.S. Department of Agriculture, National Resources Conservation Service (NRCS). *National Engineering Handbook*. Part 630: Hydrology, 1969-2001. Originally published as the *National Engineering Handbook*, Section 4: Hydrology. Available from the NRCS online at: <http://www.nrcs.usda.gov/>.
2. U.S. Department of Agriculture, Natural Resources Conservation Service. 1986. *Technical Release 55: Urban Hydrology for Small Watersheds*, 2nd Edition. Washington, D.C.
3. Pennsylvania Department of Environmental Protection. No. 363-0300-002 (December 2006), as amended and updated. *Pennsylvania Stormwater Best Management Practices Manual*. Harrisburg, PA.
4. Pennsylvania Department of Environmental Protection. No. 363-2134-008 (March 31, 2012), as amended and updated. *Erosion and Sediment Pollution Control Program Manual*. Harrisburg, PA.
5. U.S. Department of Commerce, National Oceanic and Atmospheric Administration, National Weather Service, Hydrometeorological Design Studies Center. 2004-2006. *Precipitation-Frequency Atlas of the United States, Atlas 14*, Volume 2, Version 3.0, Silver Spring, Maryland. Internet address: <http://hdsc.nws.noaa.gov/hdsc/pfds/>.
6. PennDOT **Publication 408 – Construction Specifications, Publication 584 - Drainage Manual** current editions.

APPENDICES

- Appendix A** Vandergrift Borough Stormwater Management Performance Districts
- Appendix B** Samples: Landowner Letter of Acknowledgement (for Small Projects only)
Operation and Maintenance Agreement (for SWM Site Plans)
- Appendix C** Small Project Stormwater Management Site Plan and Worksheet
- Appendix D** Stormwater Management Plan Sample Checklist
- Appendix E** Fee Schedule

Vandergrift Borough Stormwater Management Ordinance

APPENDIX A

STORMWATER MANAGEMENT PERFORMANCE DISTRICTS

See Attached Map(s)

**Also refer to the Watershed Performance District (Release Rate) Maps at
www.westmorelandstormwater.org**

NOTE: For areas not covered by current recommended Performance District (Release Rate) Maps, an 80 percent release rate is established.

Vandergrift Borough Performance District Map 1

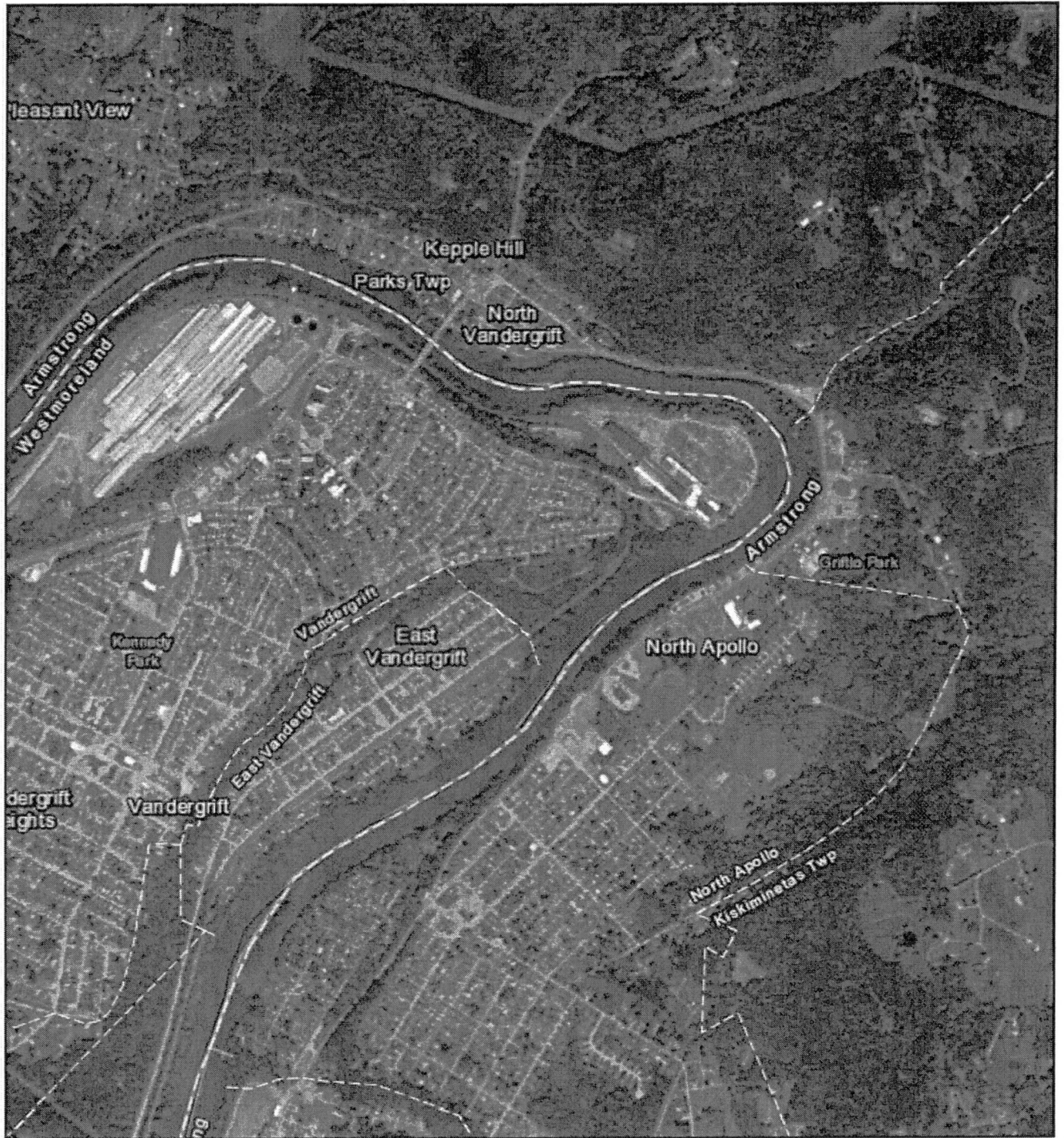

10/5/2020, 2:28:18 PM

Kiskiminetas Watershed - Stormwater Release Rates

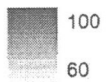

Westmoreland County Watersheds

Westmoreland County Streams - TMDL

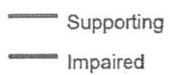

Appendix A

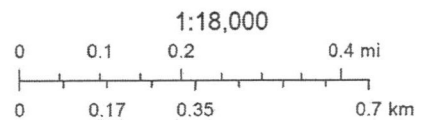

Source: Esri, Maxar, GeoEye, Earthstar Geographics, CNES/Airbus DS, USDA, USGS, AeroGRID, IGN, and the GIS User Community, Esri, HERE, Garmin, (c) OpenStreetMap contributors, and the GIS user community

Web AppBuilder for ArcGIS
Esri, HERE, Garmin, IPC | USDA FSA |

Vandergrift Borough Performance District Map 2



10/5/2020, 2:27:02 PM

Kiskiminetas Watershed - Stormwater Release Rates

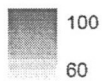

Westmoreland County Watersheds

Westmoreland County Streams - TMDL

- Supporting
- Impaired

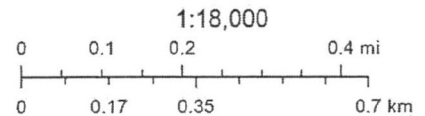

Source: Esri, Maxar, GeoEye, Earthstar Geographics, CNES/Airbus DS, USDA, USGS, AeroGRID, IGN, and the GIS User Community, Esri, HERE, Garmin, (c) OpenStreetMap contributors, and the GIS user community

Web AppBuilder for ArcGIS
Esri, HERE, Garmin, iPC | USDA FSA |

Vandergrift Borough Stormwater Management Ordinance

APPENDIX B

SAMPLE LANDOWNER LETTER OF ACKNOWLEDGMENT

For Small Project Stormwater Management Plans Only
(See Regulated Development Activity Table, Section 302)

Project Name: _____ **Date:** _____

Location: _____

- New impervious areas can potentially increase stormwater runoff from this site and the use of proposed stormwater facilities and/or best management practices (BMPs) can manage those impacts by mimicking natural processes to provide groundwater recharge and stream base flow.
- Regulated development activities on this site shall not begin until Vandergrift Borough has issued an approval for a Small Project Stormwater Management Plan.
- If stormwater management facilities and/or BMP's included on the approved Small Project Stormwater Site Plan require revisions or changes, the applicant shall submit a revised plan to the Borough of Vandergrift for approval. If a problem arises, the applicant may need to seek the assistance of a qualified professional.
- Installed stormwater facilities and/or BMP's shall not adversely affect any property, septic systems, or drinking water wells on this or any other property.
- The applicant acknowledges that the installed stormwater management facilities and/or BMP's will be a permanent fixture of the property, shall be inspected and maintained regularly to retain the original function, and cannot be altered or removed without the approval of the Borough of Vandergrift.

I (we) _____, hereby acknowledge the above statements and agree to assume full responsibility for the implementation, construction, operation, and maintenance of the proposed stormwater management facilities and/or BMPs. Furthermore, I (we) acknowledge that the steps, assumptions, and guidelines provided in the Vandergrift Borough Small Project Stormwater Management Plan and Worksheet will be adhered to.

Signature: _____ Date: _____

Signature: _____ Date: _____

Vandergrift Borough Stormwater Management Ordinance

APPENDIX B

**SAMPLE OPERATION AND MAINTENANCE (O&M) AGREEMENT
STORMWATER MANAGEMENT BEST MANAGEMENT PRACTICES (SWM BMP's)
For Stormwater Management Site Plans Only
(See Regulated Development Activity Table, Section 302)**

THIS AGREEMENT, made and entered into this day _____ of _____, 20____, by and between _____ (hereinafter the "Landowner"), and _____, Westmoreland County, Pennsylvania (hereinafter "Municipality");

WITNESSETH

WHEREAS, the Landowner is the owner of certain real property as recorded by deed in the land records of Westmoreland County, Pennsylvania, Deed Book _____ at page _____, (hereinafter "Property").

WHEREAS, the Landowner is proceeding to build and develop the Property; and

WHEREAS, the SWM BMP Operation and Maintenance (O&M) Plan approved by the Municipality (hereinafter referred to as the "O&M Plan") for the property identified herein, which is attached hereto as Appendix A and made part hereof, as approved by the Municipality, provides for management of stormwater within the confines of the Property through the use of BMPs; and

WHEREAS, the Municipality, and the Landowner, his successors and assigns, agree that the health, safety, and welfare of the residents of the Municipality and the protection and maintenance of water quality require that on-site SWM BMPs be constructed and maintained on the Property; and

WHEREAS, the Municipality requires, through the implementation of the SWM Site Plan, that SWM BMPs as required by said SWM Site Plan and the Municipal Stormwater Management Ordinance be constructed and adequately operated and maintained by the Landowner, successors, and assigns.

NOW, THEREFORE, in consideration of the foregoing promises, the mutual covenants contained herein, and the following terms and conditions, the parties hereto agree as follows:

1. The Landowner shall construct the BMPs in accordance with the plans and specifications identified in the SWM Site Plan.
2. The Landowner shall operate and maintain the BMPs as shown on the SWM Site Plan in good working order in accordance with the specific operation and maintenance requirements noted on the approved O&M Plan.
3. The Landowner hereby grants permission to the Municipality, its authorized agents and employees, to enter upon the property, at reasonable times and upon presentation of proper credentials, to inspect the BMPs whenever necessary. Whenever possible, the Municipality shall notify the Landowner prior to entering the property.
4. In the event the Landowner fails to operate and maintain the BMPs per paragraph 2, the Municipality or its representatives, upon 30 days written notice to the property owner (except in cases requiring emergency action), may enter upon the Property and take whatever action is deemed necessary to maintain said BMP(s). It is expressly understood and agreed that the Municipality is under no obligation to maintain or repair said facilities, and in no event shall this Agreement be construed to impose any such obligation on the Municipality.

5. In the event the Municipality, pursuant to this Agreement, performs work of any nature, or expends any funds in performance of said work for labor, use of equipment, supplies, materials, and the like, the Landowner shall reimburse the Municipality for all expenses (direct and indirect) incurred within 10 days of receipt of invoice from the Municipality.

6. The intent and purpose of this Agreement is to ensure the proper maintenance of the on-site BMPs by the Landowner; provided, however, that this Agreement shall not be deemed to create any additional liability of any party for damage alleged to result from or be caused by stormwater runoff.

7. The Landowner, its executors, administrators, assigns, and other successors in interests, shall release the Municipality from all damages, accidents, casualties, occurrences, or claims which might arise or be asserted against said employees and representatives from the construction, presence, existence, or maintenance of the BMP(s) by the Landowner or Municipality.

8. The Municipality intends to inspect the BMPs at a minimum of once every three years to ensure their continued functioning.

This Agreement shall be recorded at the Office of the Recorder of Deeds of Westmoreland County, Pennsylvania, and shall constitute a covenant running with the Property and/or equitable servitude, and shall be binding on the Landowner, his administrators, executors, assigns, heirs, and any other successors in interests, in perpetuity.

ATTEST:

WITNESS the following signatures and seals:

(SEAL)

For the Municipality:

For the Landowner:

ATTEST:

_____ (City, Borough, Township)

County of Westmoreland, Pennsylvania

I, _____, a Notary Public in and for the county and state aforesaid, whose commission expires on the day ____ of _____, 20____, do hereby certify that whose name(s) is/are signed to the foregoing Agreement bearing date of the ____ day of _____, 20____, has acknowledged the same before me in my said county and state.

GIVEN UNDER MY HAND THIS ____ day of _____, 20 ____.

NOTARY PUBLIC

(SEAL)

Vandergrift Borough Stormwater Management Ordinance

APPENDIX C

SMALL PROJECT STORMWATER MANAGEMENT PLAN

This small project stormwater management plan has been developed to assist those proposing residential projects to meet the requirements of the *Vandergrift Borough Stormwater Management Ordinance* (SWO) without having to draft a formal stormwater management plan. This small project stormwater management plan is only permitted for projects with new impervious area between 500 and 2,500 square feet, or total earth disturbance between 1,000 and 5,000 square feet, (See Section 302 Regulated Development Activity Table of the SWO) and by using the recommendations in this Appendix for Volume Control. Additional information can be found in Chapter 6 of the PA SW BMP Manual 2006 or most recent version.

A. What is an applicant required to submit?

All requirements of Section 306 of the Vandergrift Borough Stormwater Management Ordinance, including:

- A narrative including a brief description of the proposed stormwater facilities and BMPs, types of materials to be used, total square footage of proposed impervious areas, volume calculations;
- A sketch plan showing location of existing and proposed structures, driveways, or other paved areas with approximate surface area in square feet; location of any existing or proposed utilities, especially onsite septic system and/or potable water wells showing proximity to infiltration facilities, location and dimensions of all proposed stormwater facilities and BMPs;
- Small Project Stormwater Management Worksheet;
- Signed Landowner Letter of Acknowledgement for installation, operation and maintenance of stormwater facilities and BMP's (Refer to Appendix B); and
- Conservation District erosion and sediment control "Adequacy" letter as required by Municipal, County or State regulations;

B. Determination of Required Control Volume and Sizing Stormwater Facilities and BMPs

By following the simple steps outlined below in the provided example and Small Project Stormwater Management Worksheet, an applicant can determine the runoff volume that is required to be controlled and how to choose the appropriate stormwater facility or BMP to permanently remove the runoff volume from the site. Impervious area calculations must include all areas on the lot proposed to be covered by roof area or pavement which would prevent rain from naturally percolating into the ground, including proposed impervious surfaces such as sidewalks, driveways, parking areas, patios or swimming pools. **NOTE: Sidewalks, driveways or patios that are designed and constructed to allow for infiltration (permeable paving systems) are not included in this calculation.**

Small Project Sketch Plan: *Example*

Project Name: _____ Date: _____

Location: _____

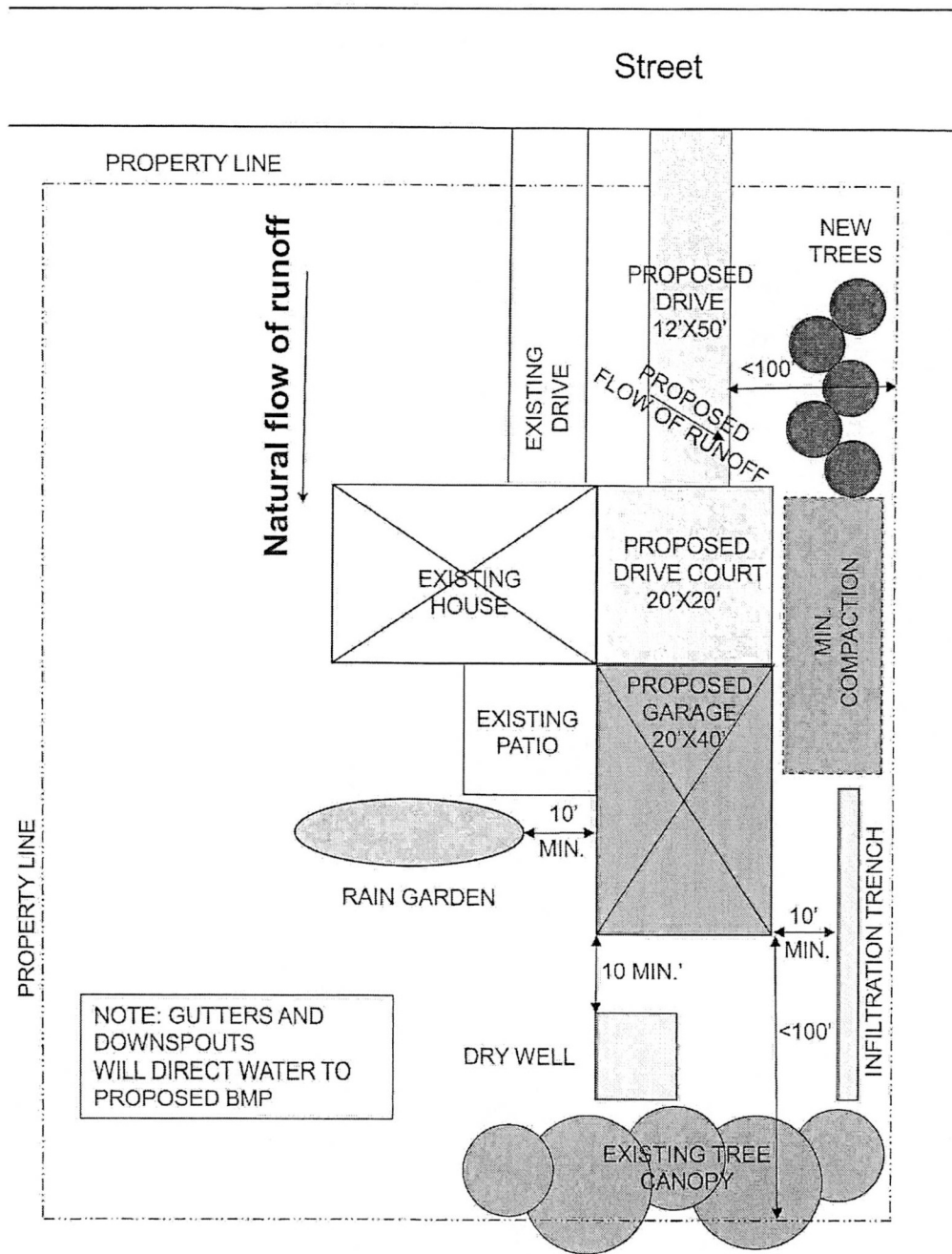

Step 1: Determine Total Impervious Surfaces and Required Control Volume:

TABLE 1: Example

New Impervious Surface	Dimensions (width x length) (FT)	Area in SF	2" storm Multiplier (0.167)	Required Control Volume 2" in CF
<i>Garage Roof</i>	<i>20'x40'</i>	<i>800 SF</i>	<i>0.167</i>	<i>133 CF</i>
<i>Driveway Court</i>	<i>20'x20'</i>	<i>400 SF</i>	<i>0.167</i>	<i>67 CF</i>
<i>Driveway</i>	<i>12'x50'</i>	<i>600 SF</i>	<i>0.167</i>	<i>100 CF</i>
		SF		CF
		SF		CF
		SF		CF

Total Required Control Volume (enter in Table 2): 300 CF

In Table 1, as in the example above and as shown on the Figure 1 example sketch plan, list each of the new improvements that create impervious area on the property along with their dimensions and total area in square feet in the first three columns. Then, depending on the design storm required by the municipality, multiply the area in square feet by the design storm multiplier to determine required control volume and list in the last column. Add each of the required control volumes together to equal the Total Required Control Volume and enter in Table 2.

Step 2: Sizing the Selected Volume Control BMP(s)

Several Best Management Practices (BMP's) are suitable for small stormwater management projects. However, their application depends on the volume required to be controlled, how much land is available, and the site constraints. Proposed residential development activities can apply both nonstructural and structural BMP's to control the volume of runoff from the site. A number of these different volume control BMP's are described below. Note that Figure 1 is an example of how these BMP's can be utilized on a property to control the total required control volume.

Credit can be taken for non-structural best management practices (BMP's) on a site to reduce the total volume required to be controlled. Credits must follow the requirements listed in this Appendix. Fill out Table 2 with proposed non-structural BMP credits and structural BMP control volumes entered in Tables 6 and 10 to meet the total required control volume.

TABLE 2: Example

Required Control Volume (Table 1)	300 CF
Non-structural BMP Credit (Table 6)	137 CF
Adjusted Required Control Volume (after credits) (Table 1 - Table 6)	163 CF
Structural BMP Control Volume (Table 10)	202 CF
TOTAL Volume Controlled (Table 6 + Table 10)	338 CF

NOTE: Total Volume Controlled shall be **greater than or equal to** Required Control Volume.

Step 3: Choosing and Measuring Non-Structural BMPs

1. Tree Planting and Preservation

Trees and forests reduce stormwater by capturing, storing and evapotranspiring rainfall through their roots and leaves. Tree roots and leaf litter also create soil conditions that promote infiltration of rainwater into the soil and that breakdown excessive nutrients and pollutants. For more information refer to the PA DEP BMP Manual 5.6.3.

Considerations for credit:

- New tree plantings must be at least 6 feet in height and have at least a 2 inch caliper trunk, and the quantity entered in Table 3
- New tree plantings must be native to Pennsylvania. Refer to <http://www.dcnr.pa.gov/Conservation/WildPlants/Pages/default.aspx>
- Existing trees must have at least a 4" caliper trunk, and must be located within 100 feet of impervious surfaces
- Measure existing tree canopy by determining the square foot area covered within the drip line of the tree(s), and enter the area in Table 4
- Site runoff should be directed via sheet flow to the area(s) of trees being used for volume control

TABLE 3: New Tree(s)

New Trees	Volume Control Multiplier	Tree Quantity	Volume Controlled (CF)
Deciduous	6 CF	2	12 CF
Evergreen	10 CF	3	30 CF

Total Volume Control Credit (new trees) enter in Table 6: 42 CF

TABLE 4: Existing Tree Canopy

Existing Tree Canopy (SF)	Distance of Impervious to Canopy (FT)	Volume Control Multiplier	Volume Controlled (CF)
SF	0 FT to 20 FT	0.0833	CF
2000	20 FT to 100 FT	0.0416	83 CF

Total Volume Control Credit (ex. trees) enter in Table 6: 83 CF



Remove all synthetic material from the root ball before planting

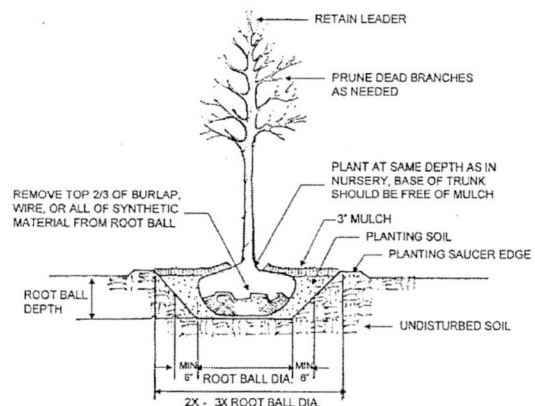

TREE PLANTING

WCD 2009 N.T.S.

2. Minimize Soil Compaction and Revegetate (lawn or meadow seeding)

When soil is overly compacted during construction it can cause a drastic reduction in the permeability of the soil and rarely is the soil profile completely restored. Runoff from overly compacted vegetated areas can resemble increased runoff from impervious areas. Minimizing soil compaction during the construction process, or restoring and amending compacted soils and revegetating them after construction can greatly increase natural infiltration on a site. For more information refer to the PA DEP BMP Manual 5.6.2 and 5.6.3.

Considerations for credit:

- Area(s) shall not be stripped of topsoil and areas shall be protected from construction vehicles and lay down space with construction fencing or mats. Enter square foot area in Table 5.
- Soil ripping and soil amendments can be used to restore the soils
- Vegetation should be used, especially native plants and meadow mixes as an alternative to lawn

TABLE 5: Minimize Soil Compaction Example

Type of stabilization	Area of minimal compaction (SF)	Volume Control Multiplier	Volume Controlled (CF)
Meadow	SF	0.0275	CF
Lawn	600 SF	0.0208	12 CF

Total Volume Control Credit (min. compaction) enter in Table 6: 12 CF



Plywood sheets protect lawn from compaction

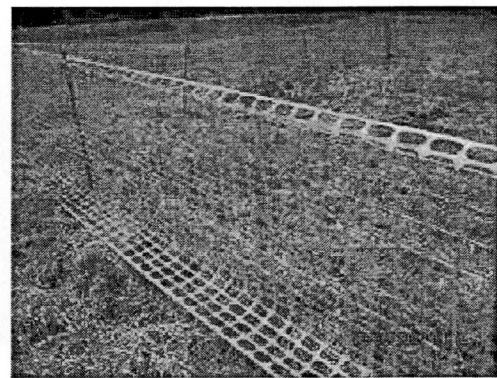

Fencing protects areas from compaction

Step 4: Determining Non-Structural BMP Credit:

TABLE 6: Non-Structural BMP Credit Summary: Example

Non- structural BMP	Storage Volume Credit (CF)
New Tree	42 CF
Existing Tree Canopy	83 CF
Minimized Soil Compaction	12 CF
TOTAL (enter in Table 2)	137 CF

Step 5: Choosing and Sizing Structural BMPs

1. Infiltration Trench

An infiltration trench is a linear stormwater management BMP consisting of a continuously perforated pipe at a minimum slope in a stone-filled trench. During small storm events, infiltration trenches can significantly reduce volume and serve in the removal of fine sediments and pollutants. Runoff is stored in the pipe and between the stones and infiltrates through the bottom of the facility and into the surrounding soil matrix. Runoff should be pretreated using vegetative buffer strips or swales to limit the amount of coarse sediment entering the trench which can clog and render the trench ineffective. In all cases, an infiltration trench should be designed with a positive overflow to a stable outlet point. For more information refer to the PA DEP BMP Manual 6.4.4.

Design Considerations:

- Continuously perforated pipe (min 4" diameter) set at a minimum slope (1%) in a stone filled, nearly level-bottomed trench on un-compacted soils.
- The trench width and depth can vary, but it is recommended that infiltration trenches be no wider than four (4) feet, and a minimum of thirty (30) inches and maximum six (6) feet in depth.
- Stone fill should be clean, angular stone, separated from soil layers by four (4) inches of straw (top and bottom) or a nonwoven geotextile (top, sides, and bottom).
- A minimum of 6" of topsoil can be placed over trench and vegetated.
- Cleanouts or inlets should be installed at both ends and at intersections of the infiltration trench and at appropriate intervals to allow access to the perforated pipe.
- The discharge or outlet from the infiltration trench should be safely conveyed to a stable vegetated area, natural watercourse, the curb or gutter line of roadway or existing storm collection/conveyance/control system as applicable.
- Volume of facility = Depth x Width x Length x Void Space of the gravel bed (assume 40%).

Maintenance:

- Cleanouts, catch basins and inlets should be inspected at least two times a year and cleaned out as necessary to maintain function of the system.
- The vegetation along the surface of the infiltration trench should be maintained in good condition and any bare spots should be re-vegetated as soon as possible.
- Vehicles should not be parked or driven on the trench and care should be taken to avoid soil compaction by lawn mowers.

TABLE 7 - Determining size of infiltration trench for volume control: *Example*

Required Control Volume (CF) From Table 2	Storage Volume Divider	Trench Volume (CF)	Trench Depth (FT)	Trench Width (FT)	Trench Length (FT)	Volume Controlled
163	0.4	413 CF	3FT	3FT	46FT	165 CF

Total Volume Control Credit (Inf. trench) **enter in Table 10:** 165 CF

Infiltration Trench Construction:

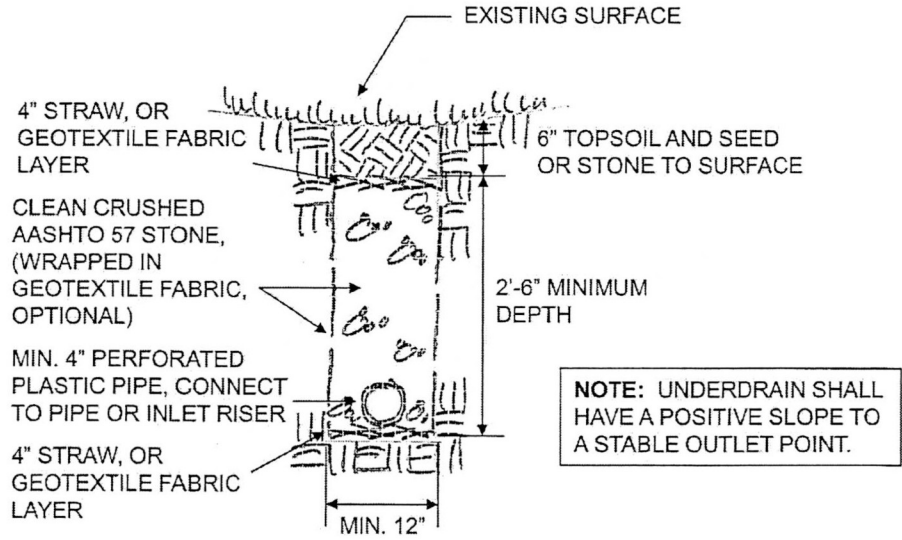

Perforated pipe covered with stone and wrapped in fabric

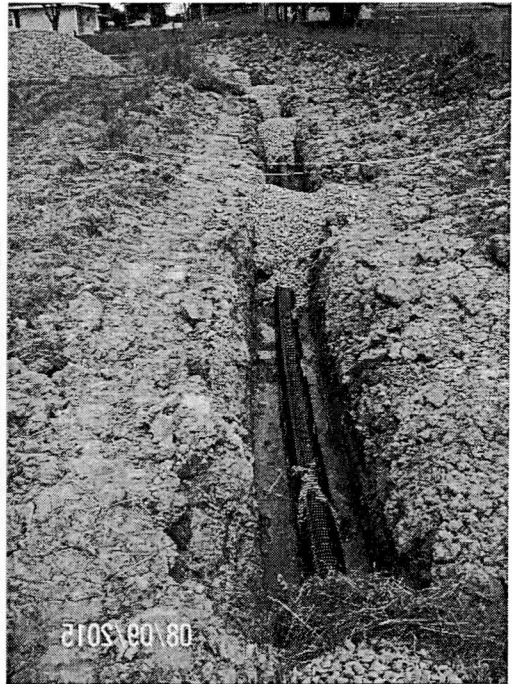

Perforated pipe covered in stone with straw separation layers

2. Rain Garden

A rain garden is a landscaped shallow depression that uses mulch, soil mix, and deep-rooted plants to capture, adsorb and infiltrate stormwater runoff from roofs, and pavement. For more information refer to the PA DEP BMP Manual 6.4.5.

Design considerations:

- A rain garden should be located on nearly level to gently sloping ground and no closer than 10 feet to a building foundation and 25 feet from septic field or wellhead.
- A rain garden can vary in length, width and depth, but should have a ponding depth of 6 to 12 inches, and a total surface depth of no greater than 18 inches.
- Side slopes within the garden should not exceed 3:1 horizontal to vertical.
- The rain garden should be constructed in layers with a (min 4”) perforated underdrain in a clean angular stone envelope, separated from soil layers by four (4) inches of straw (top and bottom) or a nonwoven geotextile (top, sides, and bottom), covered with 12 inches to 36 inches of 50-30-20 topsoil-sand-compost mix or as approved by the municipality, and 3 inches of shredded bark mulch or vegetated cover. Soil depth should be determined by plant choices and control volume requirements.
- Vegetation should be deep rooted and tolerant of wet and dry conditions, salts and environmental stress.
- An emergency overflow should be set in the rain garden such as a vertical pipe or inlet box, with basket type grate set even with the ponding depth, below the surrounding ground elevation and connected to the perforated underdrain and an outlet pipe.
- The outlet from the rain garden should be safely conveyed to a stable vegetated area, natural watercourse, the curb or gutter line of roadway or existing storm collection/conveyance/control system as applicable.

Maintenance:

- Cleanouts, catch basins and inlets should be inspected at least two times a year and cleaned out as necessary to maintain function of the system. Detritus should be removed from the rain garden as necessary to prevent clogging of the overflow outlet.
- The vegetation should be maintained in good condition and replaced as necessary. Rain garden plants may need to be watered during dry spells.
- Rain garden should be weeded and shredded bark mulch should be amended as necessary to prevent volunteer weeds.

TABLE 8 – Determining Size of Rain Garden for volume control: Example

(surface volume, soil storage volume should each be greater than or equal to required control volume)

Required Control Volume (CF) from Table 2	Ponding Depth (0.5 FT to 1.0 FT) Divider	Rain Garden Surface Area (SF)	Rain Garden Width (FT)	Rain Garden Length (FT)	Soil Mix Depth (1 FT to 3 FT) Multiplier	Soil Storage Volume Multiplier	Soil Storage Volume (<= RCV)	Volume Controlled (soil)
165 CF	0.5	330 SF	12 FT	28FT	2 FT	0.3	202 CF	202 CF

Total Volume Control Credit (rain garden) enter in Table 10: 202 CF

Rain Garden Construction:

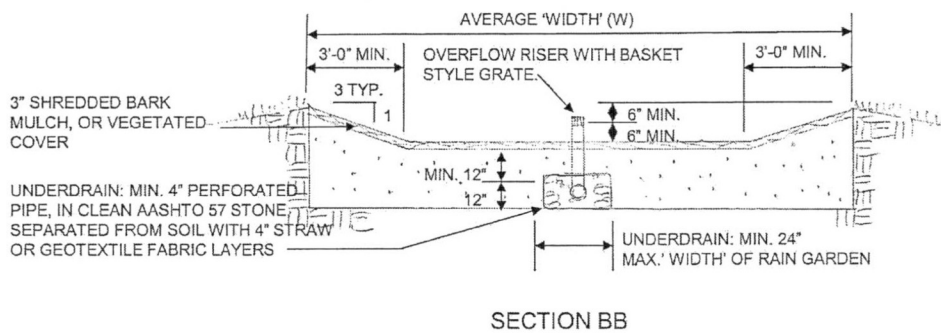
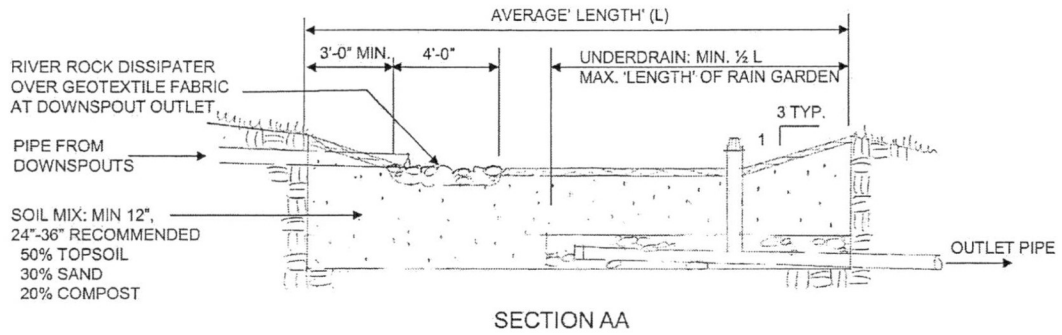

Mark rain garden location to avoid utilities



Excavate rain garden at least 10' from foundation



Separate underdrain layer from soil with fabric or straw

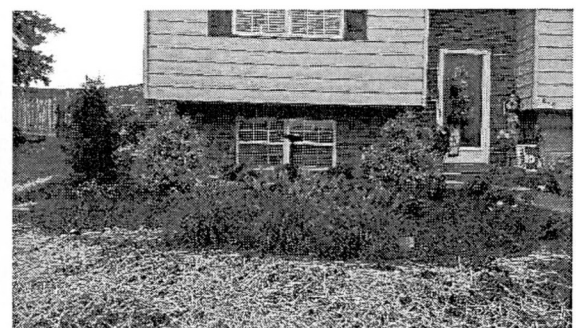

Use decorative but tolerant plants for seasonal interest

3. Dry Well / Seepage Pit

A dry well or seepage pit is a subsurface storage facility that temporarily stores stormwater runoff from roofs and infiltrates it into the surrounding soils. Roof downspouts connect directly to a dry well or seepage pit that is an excavated pit filled with clean angular stone with an overflow pipe to ensure the system will not be overwhelmed. Prefabricated chamber systems or perforated pipe sections are commercially available for use as dry wells and should be designed, constructed and maintained according to the manufacturer's recommendations. For more information on dry wells and seepage pits refer to the PA DEP BMP Manual 6.4.6.

Design considerations:

- A dry well / seepage pit should be located on nearly level to gently sloping ground and no closer than 10 feet to a building foundation and 25 feet from septic field or wellhead.
- A dry well / seepage pit can vary in length, width and depth, but should be a minimum depth of 3 feet.
- A downspout should direct water to the surface, a system of perforated pipes should distribute the water throughout the system with an inspection/cleanout pipe to the surface, and an over flow pipe should outlet excess water during intense storms.
- The storage system can be clean angular stone, separated from soil layers by four (4) inches of straw (top and bottom) or a nonwoven geotextile (top, sides, and bottom).
- The outlet from the dry well / seepage pit should be safely conveyed to a stable vegetated area, natural watercourse, the curb or gutter line of roadway or existing storm collection/conveyance/control system as applicable.

Maintenance:

- Drywells and seepage pits should be inspected at least 4 times a year, and after each storm event exceeding 1 inch.
- Remove sediment, debris, detritus and any other waste material from the system as necessary.
- Regularly clean out gutters and downspouts to ensure proper connections and to maintain effectiveness of the system.
- Replace any filter screen or clean out any sump box that may intercept roof runoff as necessary.

Table 9: Determining Size of Dry Well (stone filled) for volume control: Example

Required Control Volume (CF) from Table 2	Storage Volume Divider	Dry Well Volume (CF)	Dry Well Depth (FT)	Dry Well Width (FT)	Dry Well Length (FT)	Volume Controlled (CF)
165	0.4	413 CF	5 FT	9 FT	9.2 FT	165 CF

Total Volume Control Credit (dry well) **enter in Table 10:** 165 CF

NOTE: Applicants are required to utilize the manufacturer's recommendations for sizing proprietary stormwater infiltration systems, and to submit supporting documentation for meeting the required control volume and maintenance requirements.

Dry Well (stone filled) Construction:

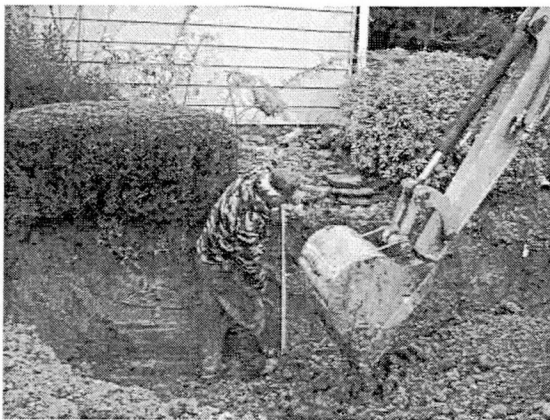
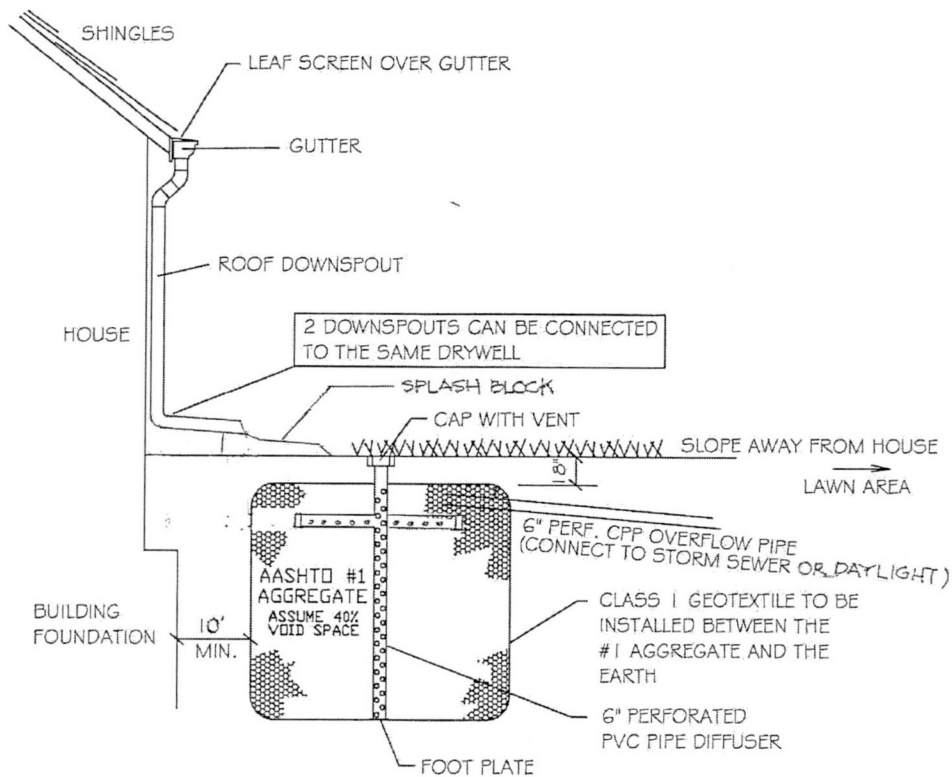

Excavate a drywell at least 10' from foundation



Separate stone fill from soil with straw layers or fabric

4. Alternative BMP Capture and Re-Use (rain barrel / cistern)

Rain barrels and cisterns are above or below ground containers used for temporary storage of rainwater, to be used for landscape irrigation and other similar uses after the rain has ended. A rain barrel or cistern **cannot be used** as a volume control because infiltration is not guaranteed after a storm event, but they are viable alternative method to capture and reuse stormwater.

Considerations:

- Rain barrels and cisterns should be directly connected to a downspout with a mosquito screen
- There should be a means to release the water after a storm event to provide storm volume for the next event
- An overflow, near the top of the container should direct water to a vegetated area away from any structures
- Barrels can be connected in series to provide more volume collection

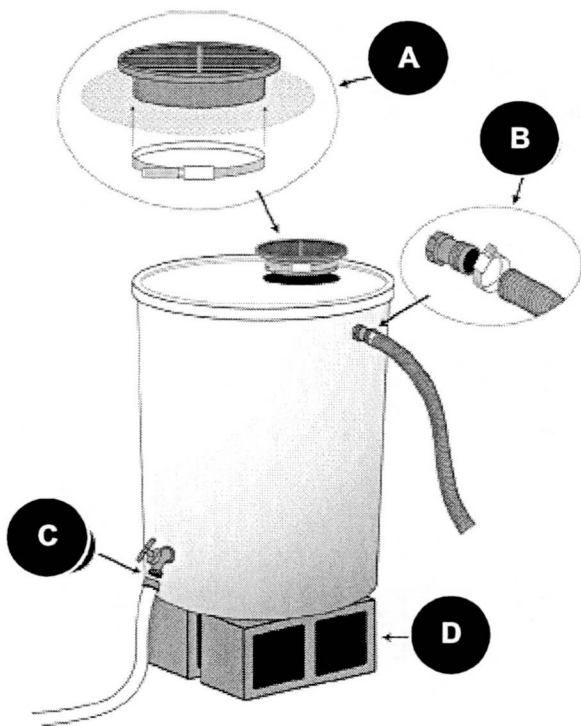

ANATOMY OF A RAIN BARREL

A – hole in top for downspout connection, with screen for mosquitoes

B – hole on side near top for overflow hose

C – hole on side near bottom for spigot

D – blocks to elevate barrel for hose connection or watering can

Step 6: Determining BMP Volume Control

TABLE 10: Structural BMP Volume Control Summary:

Structural BMP	Storage Volume (CF)	
Infiltration Trench		CF
Rain Garden	202	CF
Dry Well		CF
TOTAL (enter in Table 2)	202	CF

Use Small Project Stormwater Management Worksheet

Step 7: Post-Installation Operation and Maintenance Requirements

It is the property owner's responsibility to properly maintain any stormwater facilities and BMP's in accordance with the minimum maintenance requirements listed in this Appendix. The property owner shall submit a signed Landowner Letter of Acknowledgment, and any required declaration of easement(s) to the Borough of Vandergrift for installation, and maintenance of any proposed stormwater management facilities and BMP's. It is also the property owner's responsibility to inform any future owners of the function, operation and maintenance needed for any BMP's on the property prior to the purchase of the property.

Refer to Sample Landowner Letter of Acknowledgement in Appendix B.

**VANDERGRIFT BOROUGH
SMALL PROJECT STORMWATER MANAGEMENT WORKSHEET**

Project Name: _____ **Date:** _____

Location: _____

TABLE 1: Determination of Control Volume Requirements:

New Impervious Surface	Area in SF	2" storm Multiplier 0.167	Required Control Volume 2" in CF
	SF		CF
	SF		CF
	SF		CF
	SF		CF
	SF		CF
	SF		CF

Total Required Control Volume (enter in Table 2): _____ **CF**

TABLE 2: Determination of Volume Controlled:

Required Control Volume (Table 1)		CF
Non-structural BMP Credit (Table 6)	-	CF
Adjusted Required Control Volume (after credits) (Table 1 – Table 6)		CF
Structural BMP Control Volume (Table 10)		CF
TOTAL Volume Controlled (Table 6 + Table 10)		CF

NOTE: Total Volume Controlled shall be **greater than or equal to** Required Control Volume.

Determining Non-Structural BMP Credit:

TABLE 3: New Tree(s)

New Trees	Volume Control Multiplier	Tree Quantity	Volume Controlled (CF)
Deciduous	6 CF		CF
Evergreen	10 CF		CF

Total Volume Control Credit (new trees) **enter in Table 6:** _____ **CF**

TABLE 4: Existing Tree Canopy

Existing Tree Canopy (SF)	Distance of Impervious to Canopy (FT)	Volume Control Multiplier	Volume Controlled (CF)
SF	0 FT to 20 FT	0.0833	CF
SF	20 FT to 100 FT	0.0416	CF

Total Volume Control Credit (ex. trees) **enter in Table 6:** _____ **CF**

TABLE 5: Minimize Soil Compaction

Type of stabilization	Area of minimal compaction (SF)	Volume Control Multiplier	Volume Controlled (CF)
Meadow	SF	0.0275	CF
Lawn	SF	0.0208	CF

Total Volume Control Credit (min. compaction) enter in Table 6: _____ CF

TABLE 6: Non-Structural BMP Credit Summary:

Non- structural BMP	Storage Volume Credit (CF)
New Tree	CF
Existing Tree Canopy	CF
Minimized Soil Compaction	CF
TOTAL (enter in Table 2)	CF

Sizing of Structural BMPs:**TABLE 7: Infiltration Trench (stone filled)**

Required Control Volume (CF)	Storage Volume Divider	Trench Volume (CF)	Trench Depth (FT)	Trench Width (FT)	Trench Length (FT)	Volume Controlled
CF	0.4	CF	FT	FT	FT	CF

Total Volume Control Credit (Inf. trench) enter in Table 10: _____ CF

TABLE 8: Rain Garden (surface & soil storage volume should be greater than or equal to required control vol.)

Required Control Volume (CF)	Ponding Depth (0.5 FT to 1.0 FT) Divider	Rain Garden Surface Area (SF)	Rain Garden Width (FT)	Rain Garden Length (FT)	Soil Mix Depth (1 FT to 3 FT) Multiplier	Soil Storage Volume Multiplier	Soil Storage Volume (<= RCV)	Volume Controlled (soil)
CF	FT	SF	FT	FT	FT	0.3	CF	CF

Total Volume Control Credit (rain garden) enter in Table 10: _____ CF

TABLE 9: Dry Well (stone filled)

Required Control Volume (CF)	Storage Volume Divider	Dry Well Volume (CF)	Dry Well Depth (FT)	Dry Well Width (FT)	Dry Well Length (FT)	Volume Controlled (CF)
CF	0.4	CF	FT	FT	FT	CF

Total Volume Control Credit (dry well) enter in Table 10: _____ CF

TABLE 10: Structural BMP Volume Control Summary:

Structural BMP	Volume Controlled (CF)
Infiltration Trench	CF
Rain Garden	CF
Dry Well	CF
TOTAL (enter in Table 2)	CF

**Vandergrift Borough Stormwater Management Ordinance
APPENDIX D**

Vandergrift Borough Stormwater Management Plan Sample Checklist

See Vandergrift Borough Stormwater Ordinance for complete requirements

Project Name: _____ Date: _____

Location: _____ Performance District: _____

Type of Plan: ___ Residential, ___ Commercial, ___ Institutional, ___ Industrial, ___ Recreational, ___ Other

Owner: _____ Contact Information: _____

Plan Preparer: _____ Contact Information: _____

Submission Requirements

- Checklist
- Application
- Fees and
- Location map (USGS)
- 3 sets of completed plans, calculations, narrative, etc. (2 sets for the Borough and 1 set for the Engineer)
- E&S plan, as submitted for approval
- Operation and maintenance agreement
- Municipal notification(s)
- Financial guarantees, maintenance fund

General Requirements

Narrative:

- Project description, including Watershed Performance District, existing and proposed features and improvements, soils and limitations, landform, land cover, drainage areas, utilities, proposed SWM facilities and BMP's, easements and other information required by the [Municipality] stormwater ordinance
- Stormwater calculations
- Project schedule
- Construction sequence, including phases if applicable
- Justification for SWM facilities and/or BMPs
- Operation and Maintenance requirements and responsible party(s)

Plan:

- Location map (USGS)
- Watershed Performance District
- Existing natural features
- Soils; and limitations
- Landform; existing and proposed contours at 2' intervals, or 5' intervals for slopes >15%
- Land cover; existing and proposed improvements
- Drainage areas; existing and proposed
- Utilities; existing and proposed
- SWM facilities and BMPs; existing and proposed
- Easements, including offsite easements for drainage
- Stormwater construction details and sections (as applicable)
- Stormwater construction notes and sequence
- Operation and Maintenance requirements and responsible party(s)

Vandergrift Borough Stormwater Management Ordinance

APPENDIX E

FEE SCHEDULE

(See Regulated Development Activity Table §302)

Exemptions

(Sites with 0 Sq. Ft. of new impervious area and less than 1 Acre of disturbed area)

1. Application Fee: \$10
2. Review Fee: \$50 + Subsequent Review Fee (if required): \$100/Hour⁽¹⁾
3. Site Inspection Fee: \$150.00 per inspection, if required. ⁽¹⁾

No-Harm Evaluations

(Sites with less than 500 Sq. Ft. of new impervious area & less than 1,000 Sq. Ft. of disturbed area)

1. Application Fee: \$10
2. Review Fee: \$50 + Subsequent Review Fee (if required): \$100/Hour⁽¹⁾
3. Site Inspection Fee: \$150.00 per inspection, if required. ⁽¹⁾

Waiver / Modification / Demonstrated Equivalency (Subject to Municipal approval)

(Sites with less than 1 acre of new impervious area & less than 1 acre of disturbed area)

1. Application Fee: \$50
2. Review Fee: \$150 + Subsequent Review Fee (if required): \$100/Hour⁽¹⁾
3. Site Inspection Fee: \$150 per inspection, if required. ⁽¹⁾

Small Project Site Plan

(Sites with 500 S.F. to 2,500 S.F. of new impervious area & 1,000 S.F. to 5,000 S.F. of disturbed area)

1. Application Fee: \$50
2. Review Fee: \$150 + Subsequent Review Fee (if required): \$100/Hour⁽¹⁾
3. Site & Construction Inspection Fee: \$150 + Subsequent Inspection Fee (if required): \$100/Hour⁽¹⁾
4. Post- Construction Inspections Deposit, if required: \$600 (\$150/inspection for 4 inspections). ⁽³⁾
5. Post- Construction Maintenance Deposit, if required: Determined according to §604. ⁽²⁾

Stormwater Management Site Plan

(Sites with more than 2,500 Sq. Ft. of new impervious area & more than 5,000 Sq. Ft. of disturbed area)

1. Application Fee: \$100
2. Review Fee: \$600 + Subsequent Review Fee (if required): \$100/Hour⁽¹⁾
3. Site & Construction Inspection Fee: \$1,000 + Subsequent Inspection Fee (if required): \$100/Hour⁽¹⁾
4. Post- Construction Inspections Deposit: \$1,200 (\$300/inspection for 4 inspections) ⁽³⁾
5. Post- Construction Maintenance Deposit: Determined according to §604. ⁽²⁾

Notes:

(1) The Borough may invoice applicants for associated costs over and above the amount of fees paid per §706.

(2) See §604 regarding required deposits to the Stormwater Facility and BMP Operation and Maintenance Fund.

(3) Upon completion of Construction in year 1 and every 3 years (years 4, 7 and 10) for a period of 10 years.